



LuK GearBOX Repair Solution for Manual Transmission



Disassembly and Assembly

Peugeot/Citroen MA Transmission

From 01/2003



The content of this brochure is not legally binding and is solely intended for information purposes. Where legally permissible, all liability on the part of Schaeffler Automotive Aftermarket GmbH & Co. KG in connection with this brochure is excluded.

All rights reserved. Any reproduction, distribution, communication, public reproduction or other publication of this brochure in its entirety or in part without prior written consent from Schaeffler Automotive Aftermarket GmbH & Co. KG is not permitted.

Copyright ©
Schaeffler Automotive Aftermarket GmbH & Co. KG
May 2018

Schaeffler in the Automotive Aftermarket – more innovation, more quality and more service.

Schaeffler in the Automotive Aftermarket – always the first choice for vehicle repair.

Whenever a vehicle needs to go to the garage, our products and repair solutions are the first choice for the repair work. With the four product brands LuK, INA, FAG and Ruville, as well as our service brand REPERT, we are a reliable partner worldwide. From cars to light and heavy-duty commercial vehicles or tractors, the components are optimally calibrated to enable rapid and professional parts replacement.

Our products are underpinned by a comprehensive system approach. Innovation, technical expertise and the highest level of product and production quality make us not only one of the leading development partners for series production, but also a pioneering provider of spare parts that maintain their value plus complete repair solutions for clutch and release systems, and engine, transmission and chassis applications – always with OEM quality. In addition, we offer technical services for the garage relating to our products and repair solutions through our REPERT brand.

For more than 50 years, we have been providing all of the components necessary for repairing powertrains via our LuK brand: In addition to the LuK RepSet family and the complete hydraulic release system for professional clutch repair, the portfolio also includes the dual mass flywheel as well as components for the professional repair of transmissions and differentials – plus professional solutions for repairing drives in commercial vehicles and tractors.

Schaeffler REPERT – the service brand for garage professionals.

Via the REPERT brand, we offer a comprehensive range of services based around our products and repair solutions from the LuK, INA, FAG and Ruville brands. Are you looking for specific information regarding damage diagnostics? Or do you need some specific tools to simplify your everyday work in the garage? Whether you use the online portal, service hotline, installation instructions and videos, training courses or events – you will receive all technical services from a single source.

Register now in just a few clicks and for free at www.repxpert.com.

SCHAEFFLER
REP>XPERT



The parts contained in the LuK GearBOX can be assigned to the installation position in the transmission using the parts list and this brochure. The figures in the instructions are used for this purpose, e.g. (1).

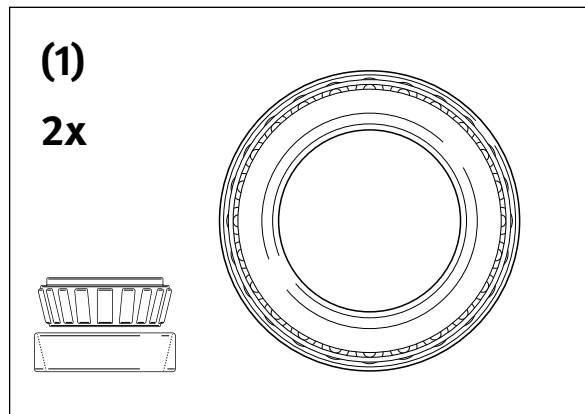

Fig. 1

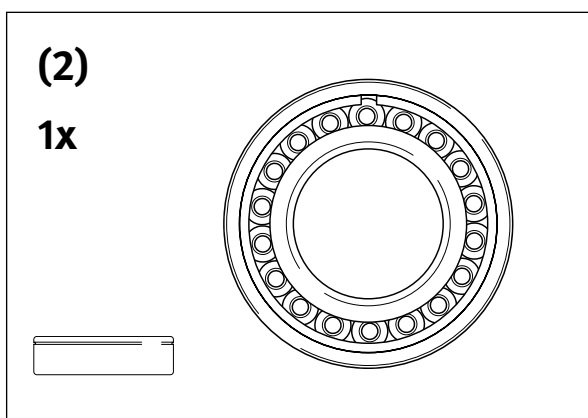

Fig. 2

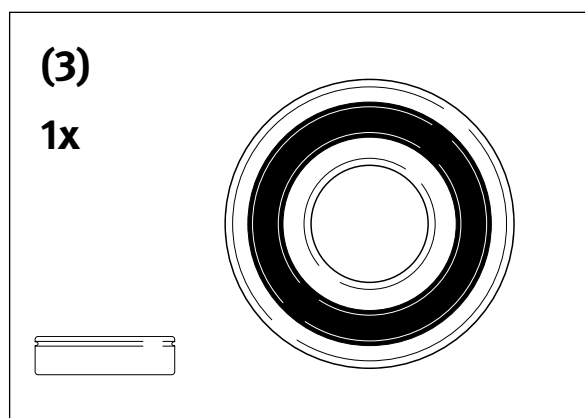

Fig. 3

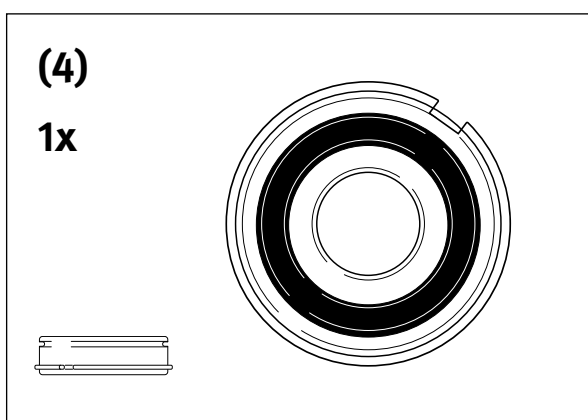

Fig. 4

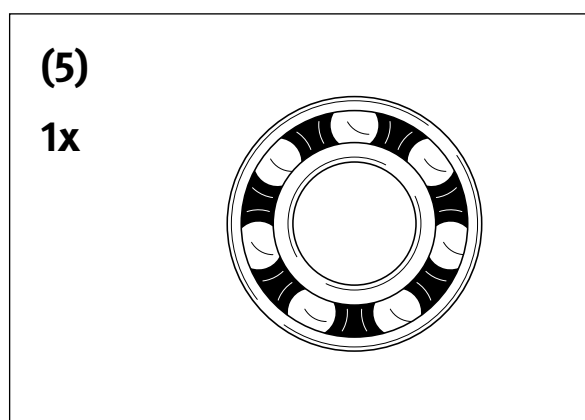

Fig. 5

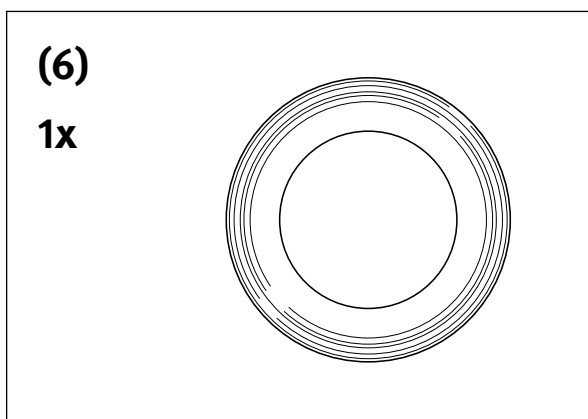

Fig. 6

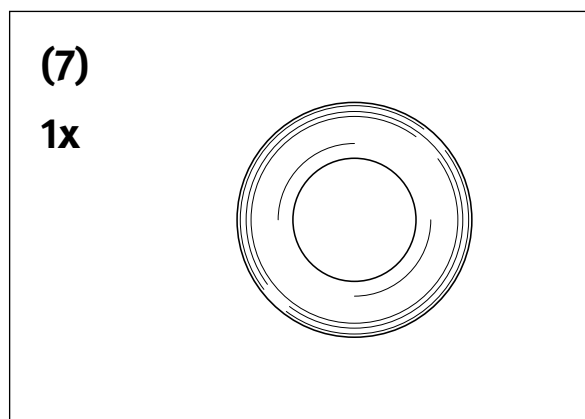

Fig. 7

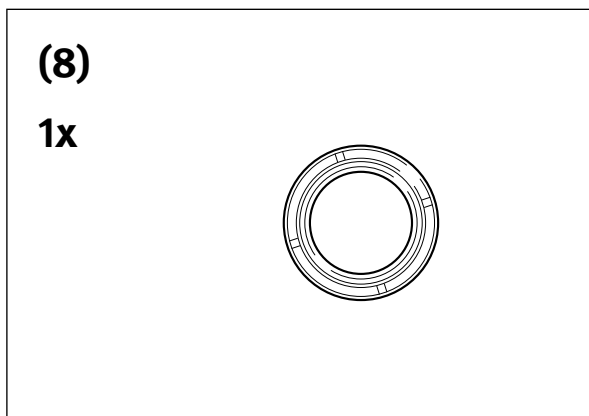

Fig. 8

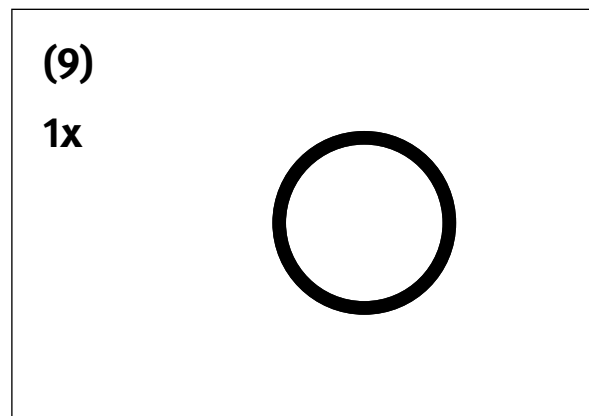

Fig. 9

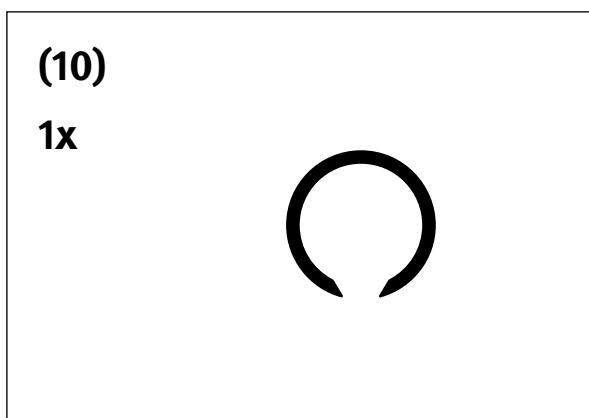

Fig. 10

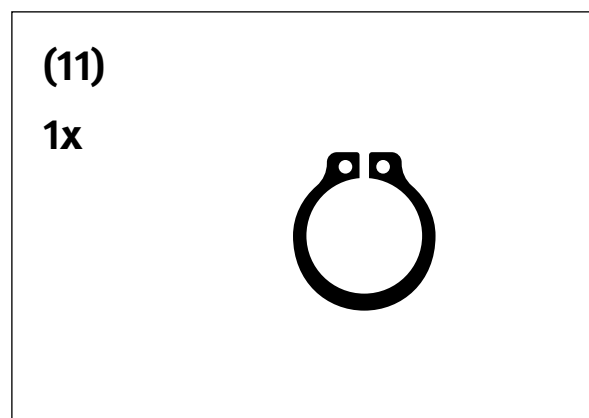

Fig. 11

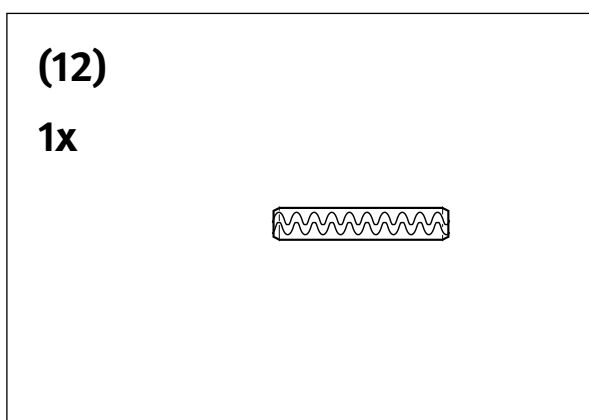

Fig. 12

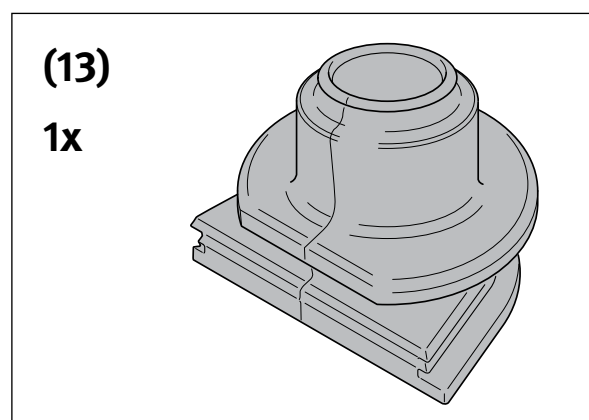

Fig. 13

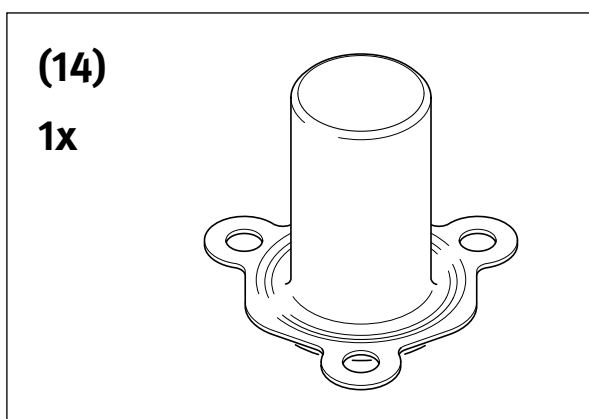

Fig. 14

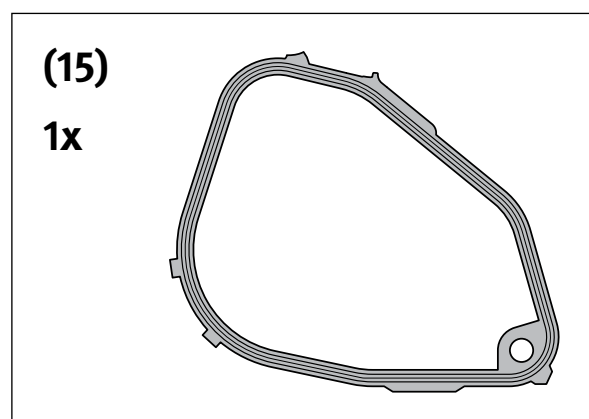

Fig. 15

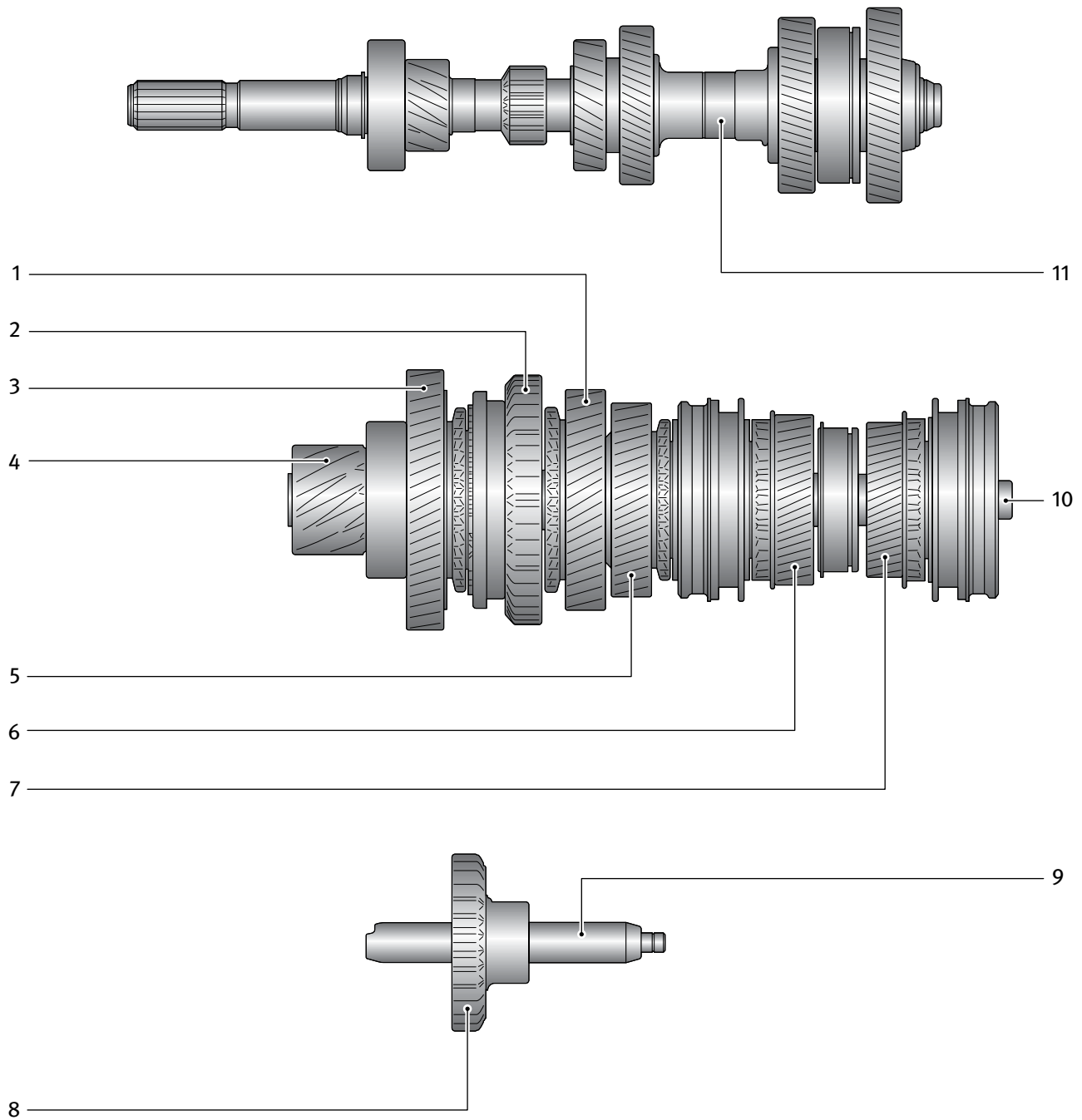

Fig. 16

- | | |
|------------------------------|-------------------------------|
| 1. 2nd gear | 4. Differential toothed gear |
| 2. Reverse gear | 5. 3rd gear |
| 3. 1st gear | 6. 4th gear |
| 4. Differential toothed gear | 7. 5th gear |
| 5. 3rd gear | 8. Reverse sliding gear |
| 6. 4th gear | 9. Reverse sliding gear shaft |
| | 10. Output shaft |
| | 11. Drive shaft |

The country-specific and vehicle manufacturer-specific safety requirements and guidelines must be followed during all work!

- Drain the transmission oil and screw the drain plug back in
Tightening torque: 33 Nm
- Remove the gearbox in accordance with the vehicle manufacturer's specifications

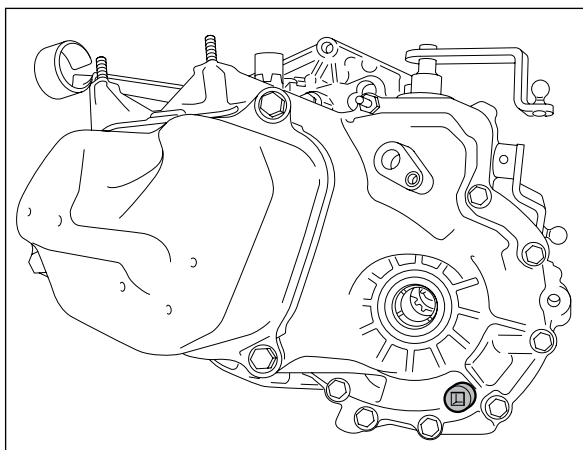

Fig. 17

- Remove bolts from the guiding sleeve
- Disassemble the guiding sleeve including the sealing ring of the input shaft
- Clean the thread in the clutch cover using a thread tap

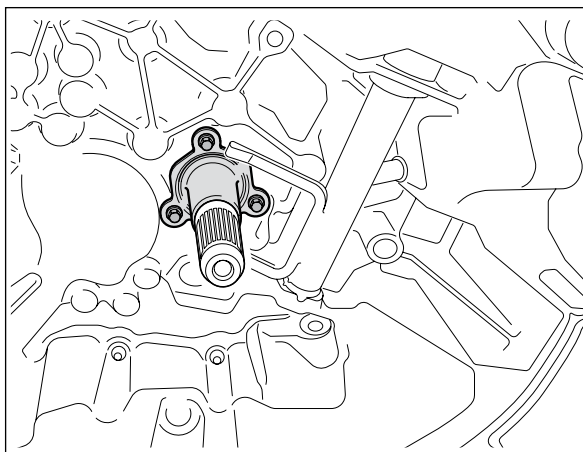

Fig. 18

- Remove reversing light switch [1] and speedometer drive [2]

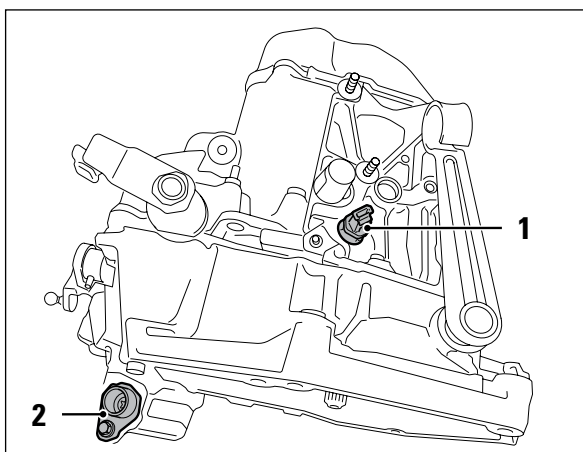

Fig. 19

- Remove transmission cover for fifth gear

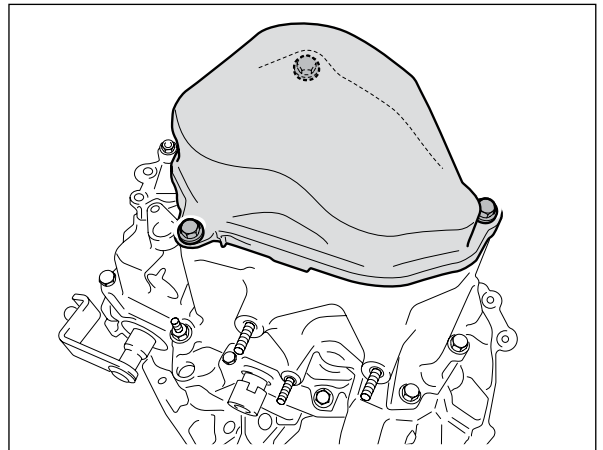

Fig. 20

- Remove the spring pin of the shift fork for fifth gear

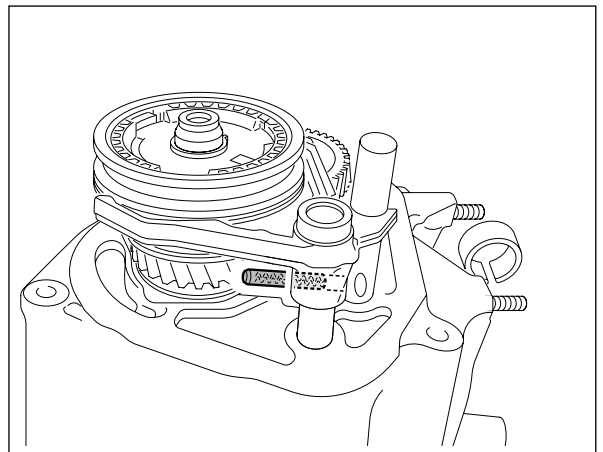

Fig. 21

- Remove snap ring [1] and support washer [2] from the synchronizer unit for fifth gear

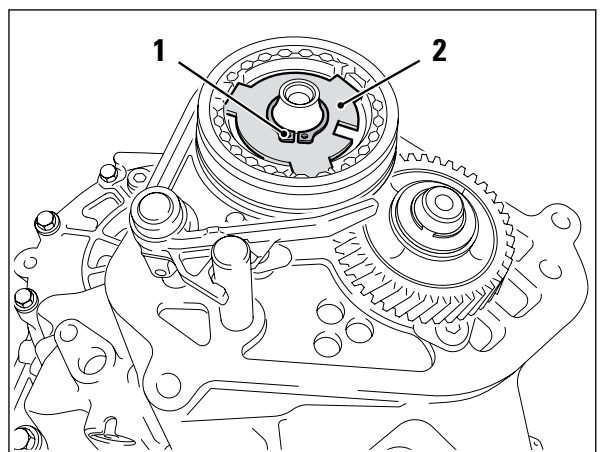

Fig. 22

- Remove synchronizer unit and fifth gear from the output shaft

Note:

Label the synchronizer body and selector sleeve so that they match. The two components are matched to one another. It is important to ensure that the shift fork is carried upwards to prevent the synchronizer unit from falling apart.

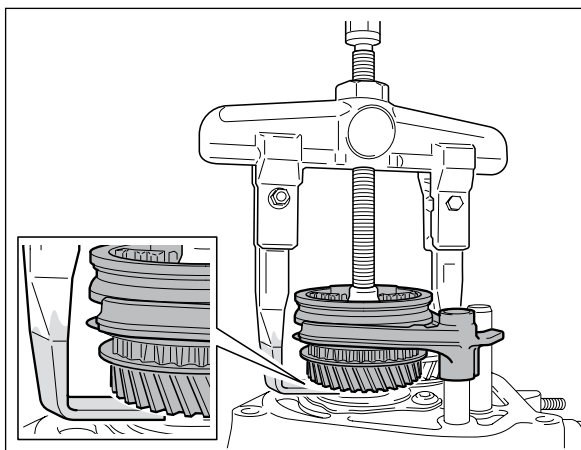

Fig. 23

- Remove the snap rings [1 and 2] from the output shaft and drive shaft and remove the spring washer [3]

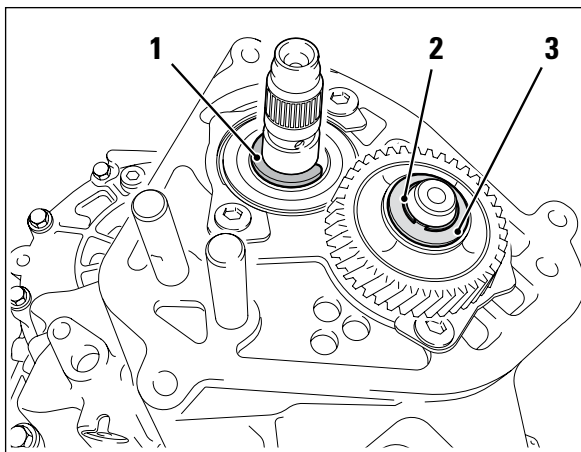

Fig. 24

- Remove the fixed gear for fifth gear

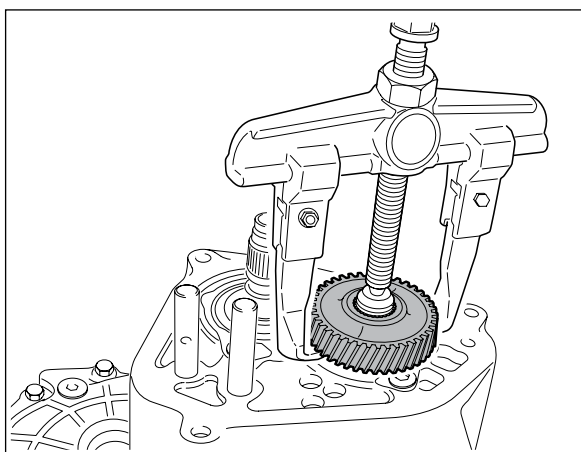

Fig. 25

- Unscrew the bolts, lift the output shaft or drive shaft and remove the bearing snap rings
- Clean the thread in the transmission housing using a thread tap

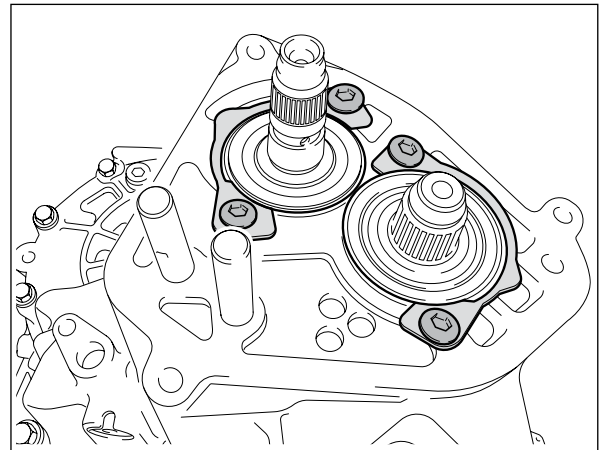

Fig. 26

- Remove bolts from the transmission housing

Note:
Mark the installation position of the housing bolts.

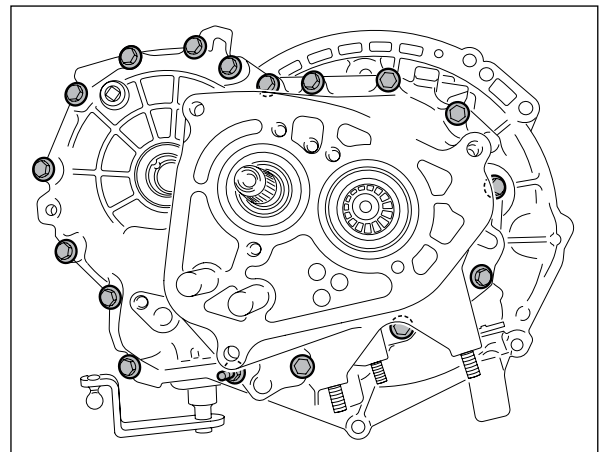

Fig. 27

- Remove the transmission housing in an upward motion

Note:
Do not damage the sealing surfaces.

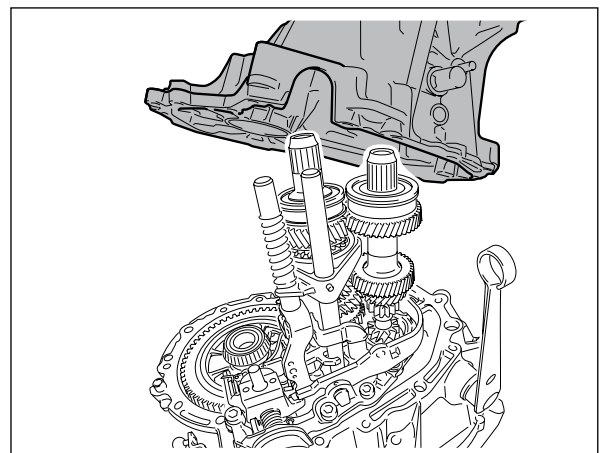

Fig. 28

- Move selector sleeves into the neutral position
- Remove the shaft of the reverse sliding gear [1]
- Remove the reverse sliding gear [2]

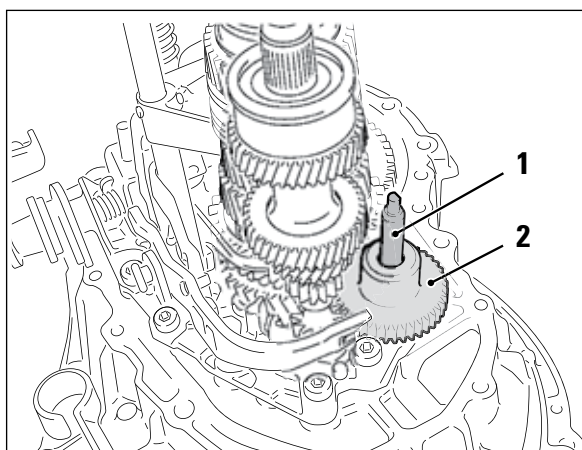

Fig. 29

- Remove the bearing pin for the reverse gear shift fork using a suitable tool

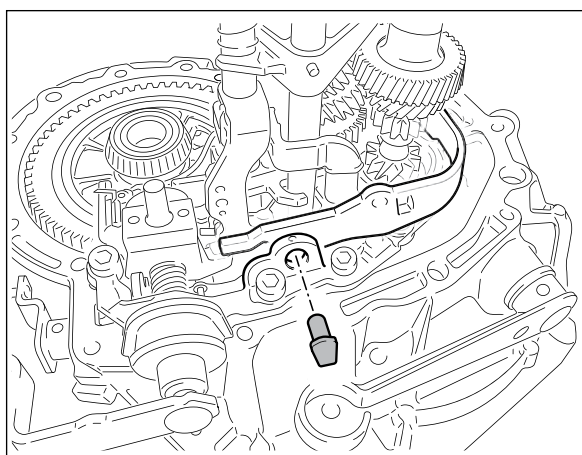

Fig. 30

- Disassemble the reverse gear shift fork
- Remove the mounting screw for the intermediate plate behind the locking key

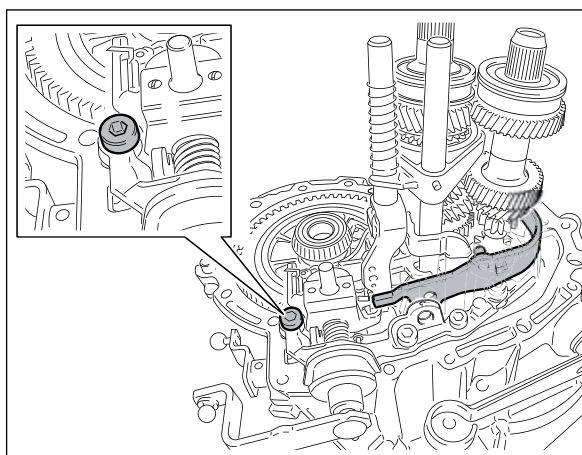

Fig. 31

- Engage second gear (pull out the front shift lever and rotate anticlockwise)
- Remove the roll pin [1] for the shift finger

Note:
Retain roll pin [1].

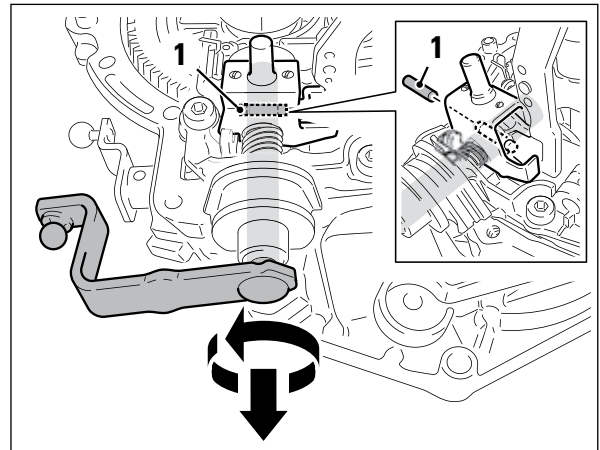

Fig. 32

- Pull out shift lever [1]
- Remove spring [2]

Note:
Wear protective goggles!

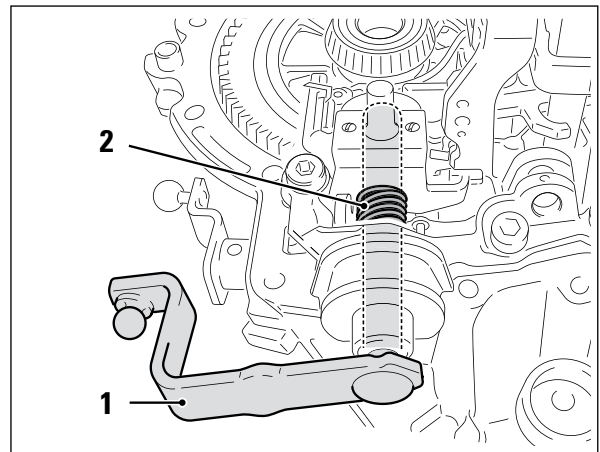

Fig. 33

- Disassemble the locking key

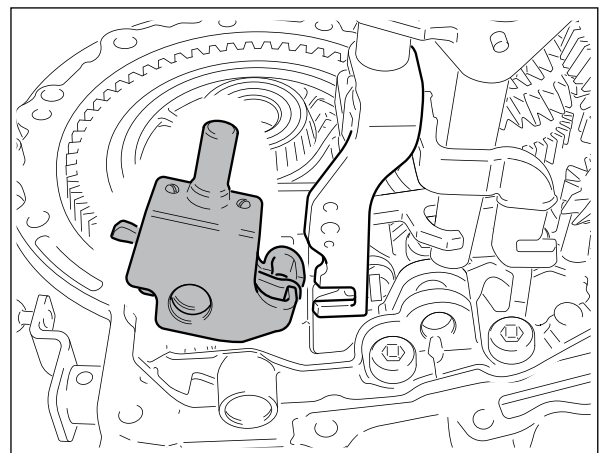

Fig. 34

- Lift the drive shaft and output shaft with shift forks and shift rods out of the clutch housing

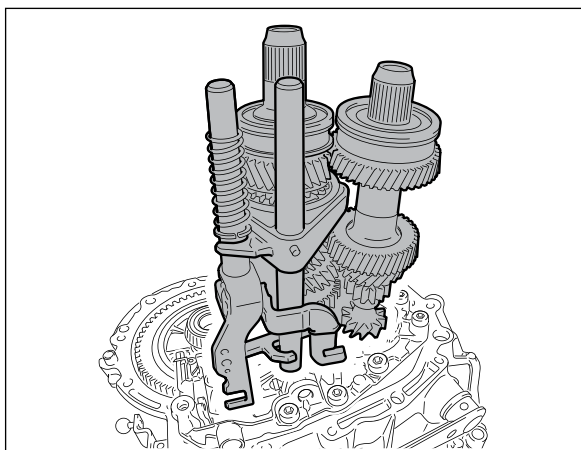

Fig. 35

- Remove bolts and lift the intermediate plate off the clutch cover
- Clean the thread in the clutch cover using a thread tap

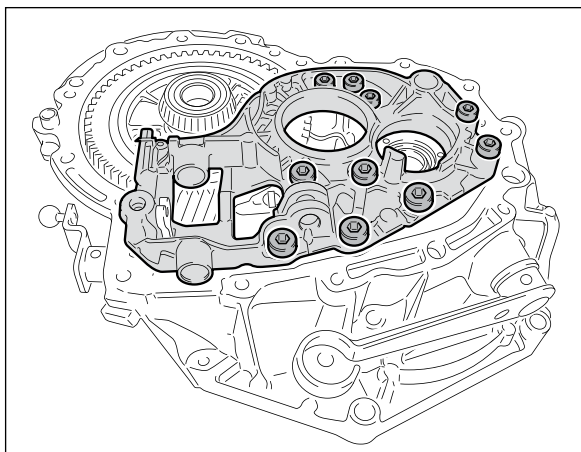

Fig. 36

- Remove and clean magnet [1]
- Disassemble locking finger [2] for the reverse gear shift fork incl. spring
- Lift out the differential [3]

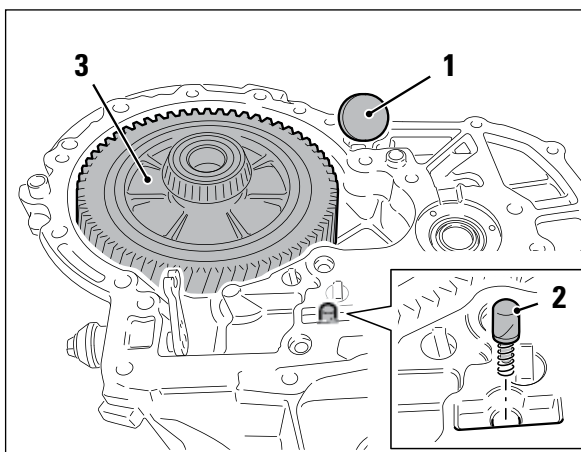

Fig. 37

- Remove the roll pin [1] of the selector lever [2] using a suitable tool
- Remove selector lever [2] and pull out shift fork shaft [3]

Note:
Retain roll pin [1].

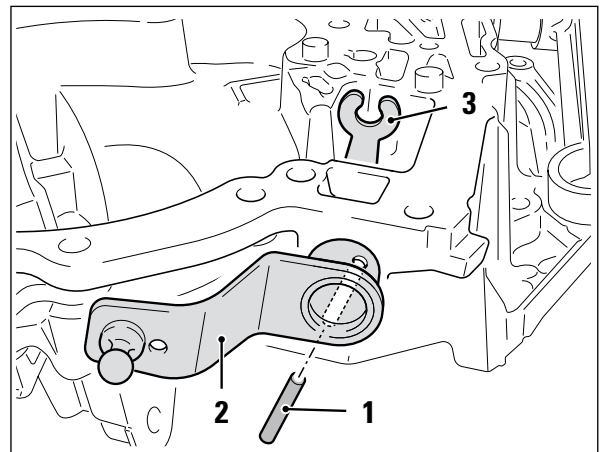

Fig. 38

- Replace rotary shaft seal [8] on the shift fork shaft

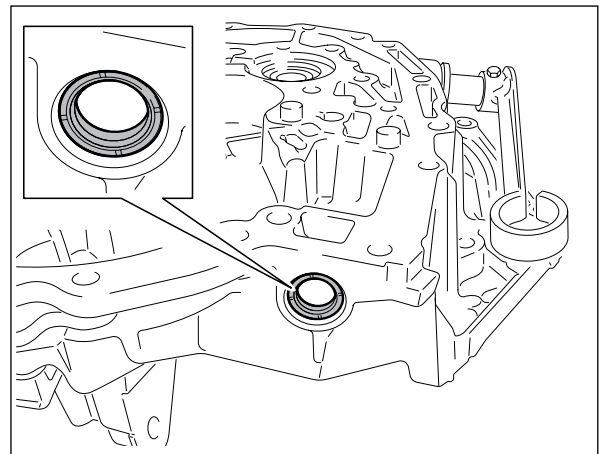

Fig. 39

- Insert shift fork shaft [3] and mount selector lever [2]
- Press in roll pin [1] using a suitable tool

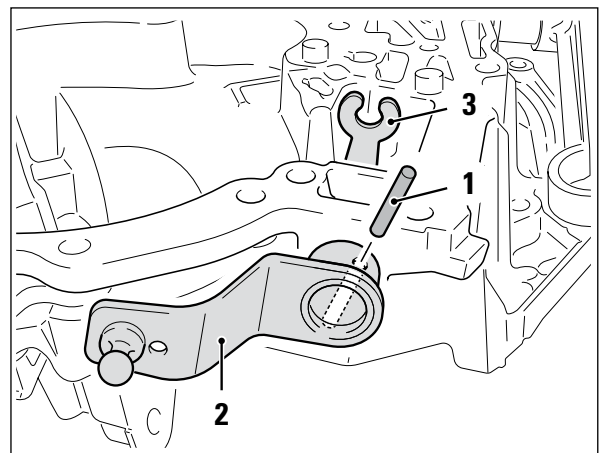

Fig. 40

- Remove the flanged shaft seal of the clutch cover

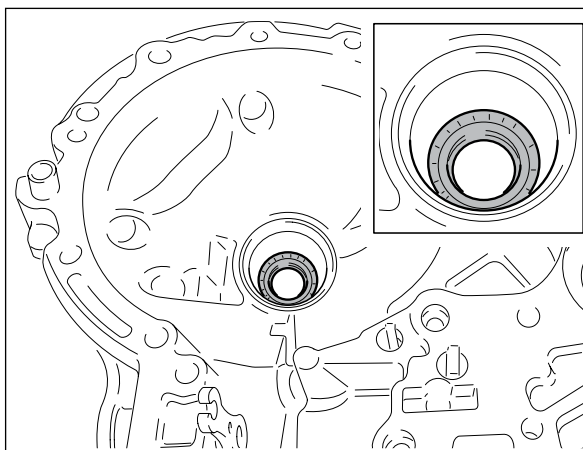

Fig. 41

- Replace the clutch cover-side bearing shell (1) for the differential bearing

Note:

The inner and outer ring of the tapered roller bearings are a pair (do not mix them up).

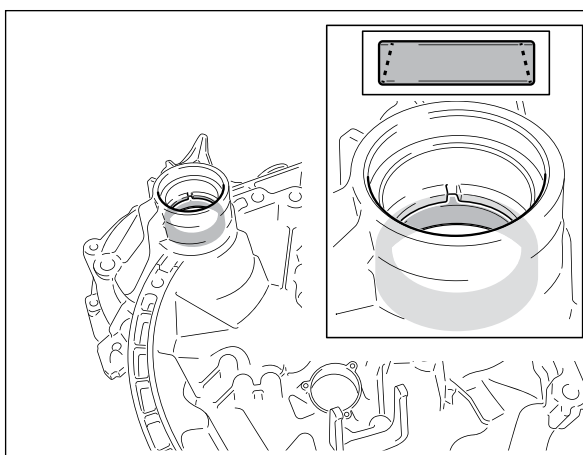

Fig. 42

- Press in the new flanged shaft seal (7) for the clutch cover

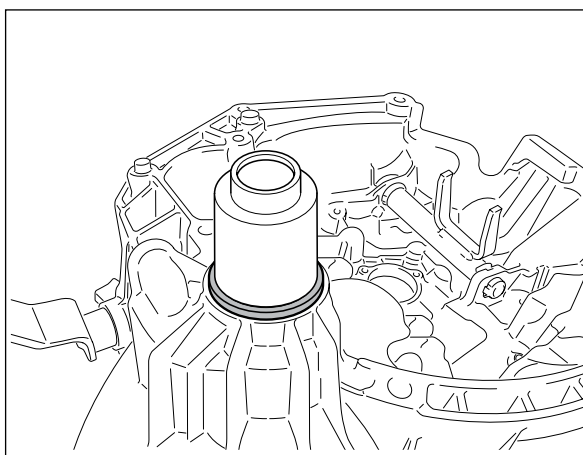

Fig. 43

- Remove flanged shaft seal for the transmission housing

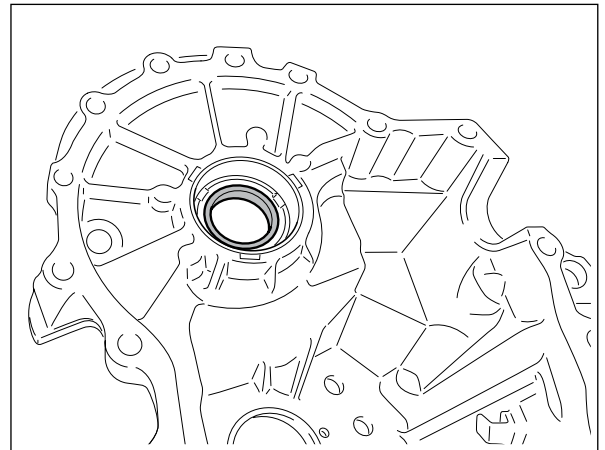

Fig. 44

- Replace the transmission housing-side bearing shell (1) for the differential bearing

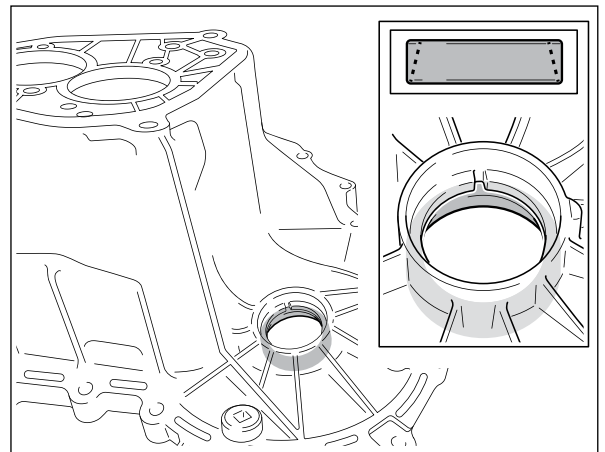

Fig. 45

- Press in the new flanged shaft seal (6) for the transmission housing

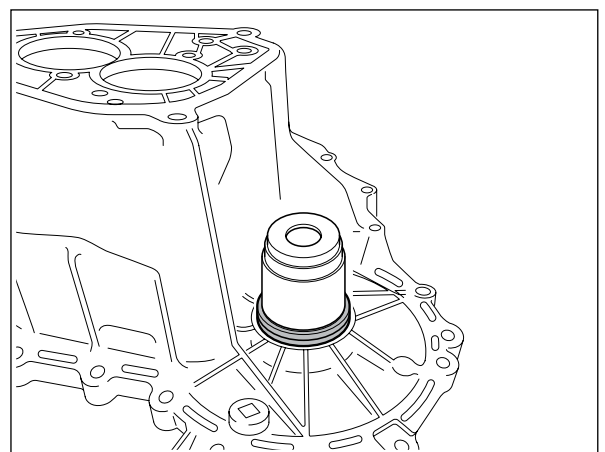

Fig. 46

- Disassemble the speedometer drive gear

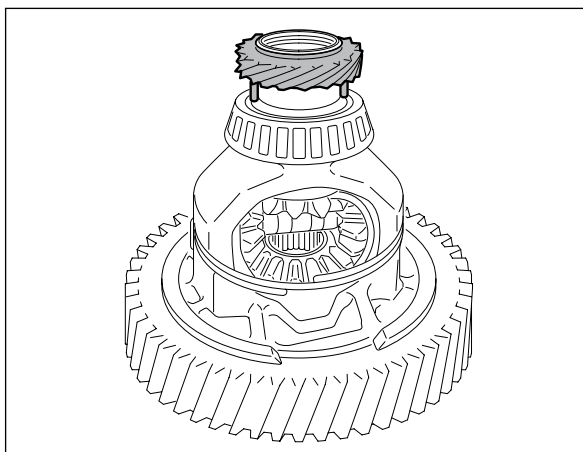

Fig. 47

- Remove both differential bearings

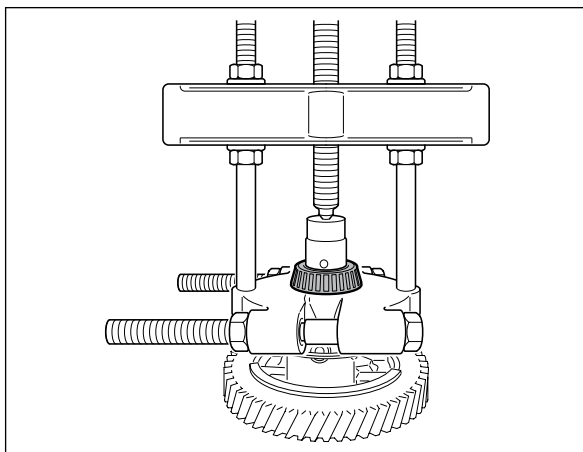

Fig. 48

- Press on the new differential bearings (1)

Note:
 Press on the inner ring with the appropriate sleeve.

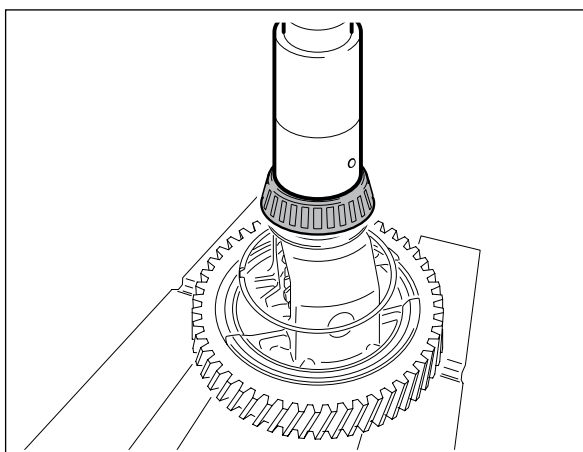

Fig. 49

- Mount the speedometer drive gear

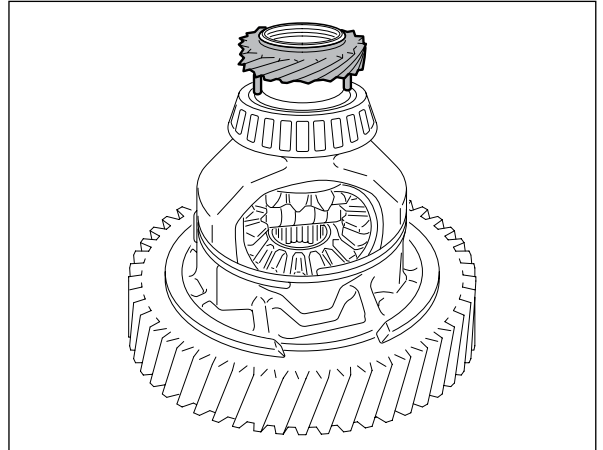

Fig. 50

- Press off the bearing of the drive shaft

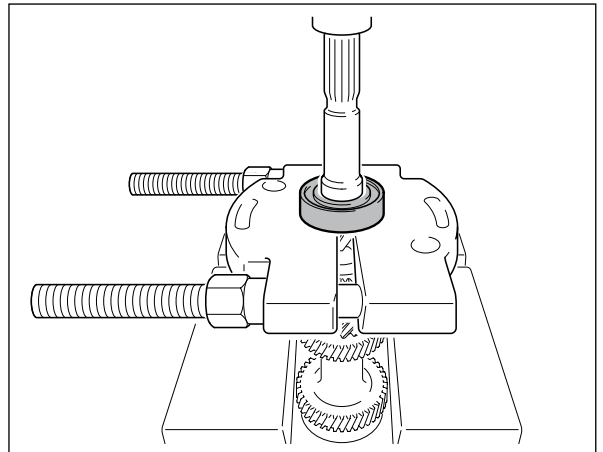

Fig. 51

- Press off the second bearing of the drive shaft

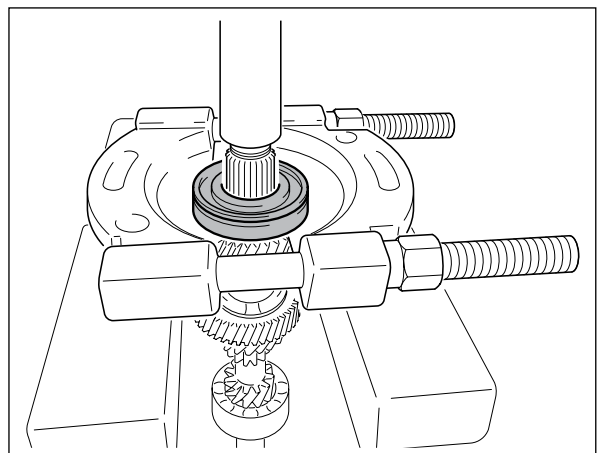

Fig. 52

- Press on the new bearing (5) of the drive shaft

Note:

Support the inner ring of the bearing (5) with the appropriate sleeve.

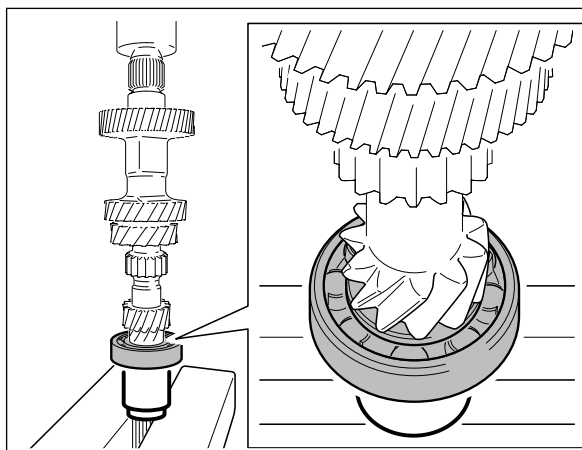

Fig. 53

- Press on the new bearing (3) of the drive shaft with the groove facing upwards

Note:

Press on the inner ring with a suitable sleeve.

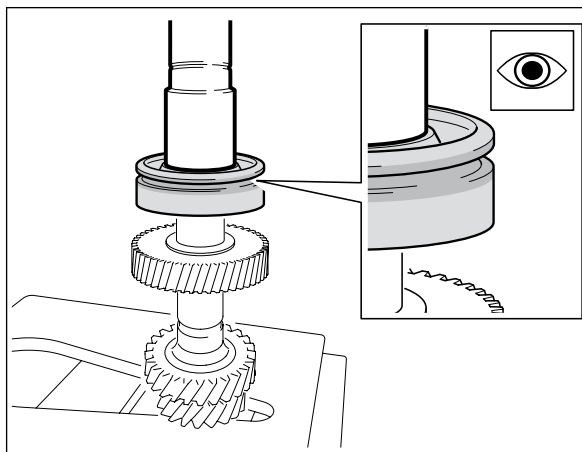

Fig. 54

- Press off the bearing of the output shaft

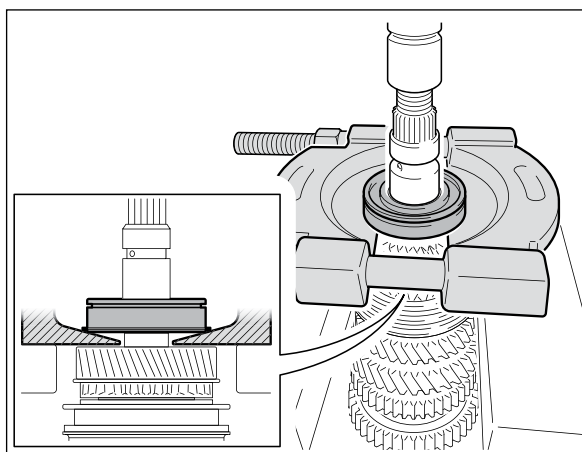

Fig. 55

- Remove washer [1], fourth gear [2], synchro ring for fourth gear [3], selector sleeve for third/fourth gear [4] and synchro ring for third gear [5] off the output shaft

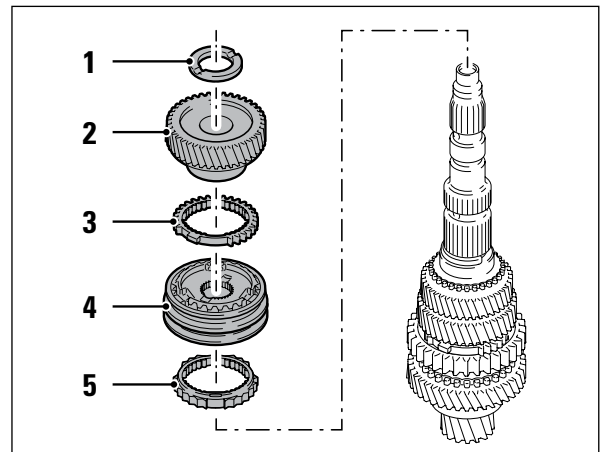

Fig. 56

- Remove snap ring [6]
- Remove third gear [7] off the output shaft

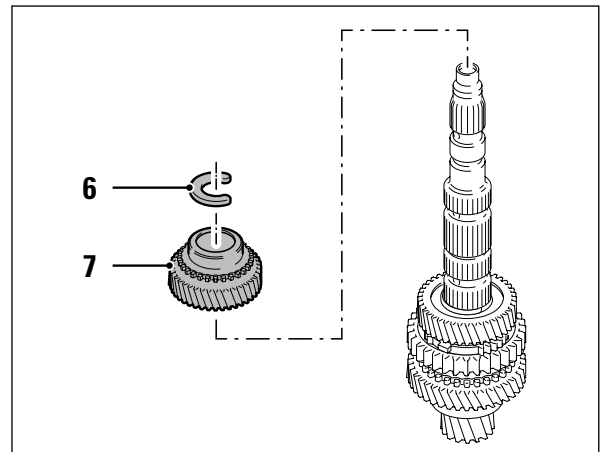

Fig. 57

- Remove snap ring [8]
- Remove second gear [9], synchro ring for second gear [10], synchronizer unit for first/second gear [11] and synchro ring for first gear [12] off the output shaft

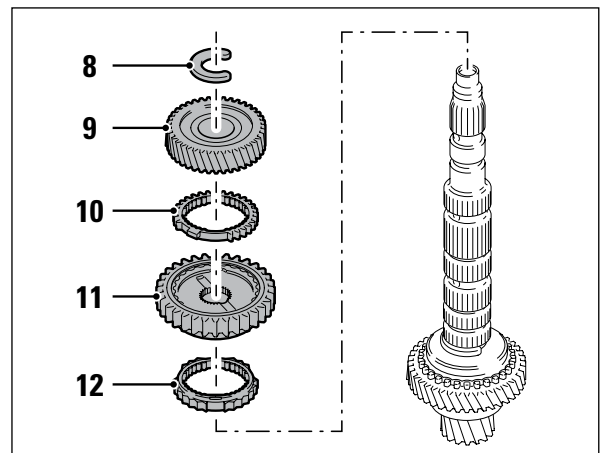

Fig. 58

- Remove snap ring [13]
- Remove first gear [14] off the output shaft
- Remove snap ring [15]

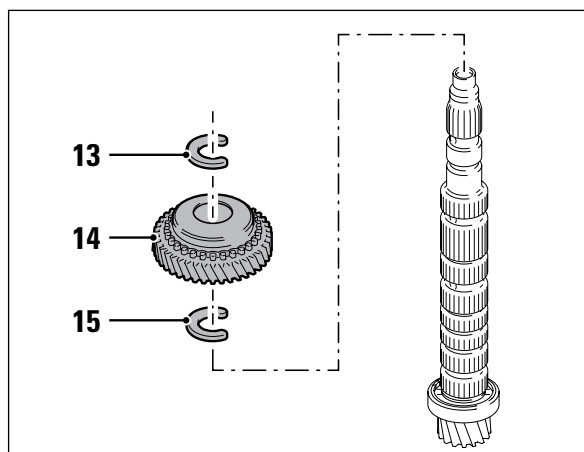

Fig. 59

- Press off the bearing of the output shaft

Note:

Take the installation position of the bearing into account.

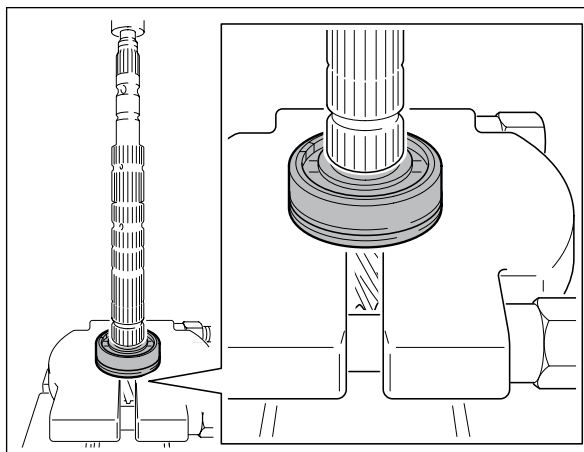

Fig. 60

- Press on the new bearing (2) of the output shaft using a suitable tool

Note:

Support the inner ring of the bearing (2) with the appropriate sleeve.

Do not damage the lubrication connection when press-fitting.

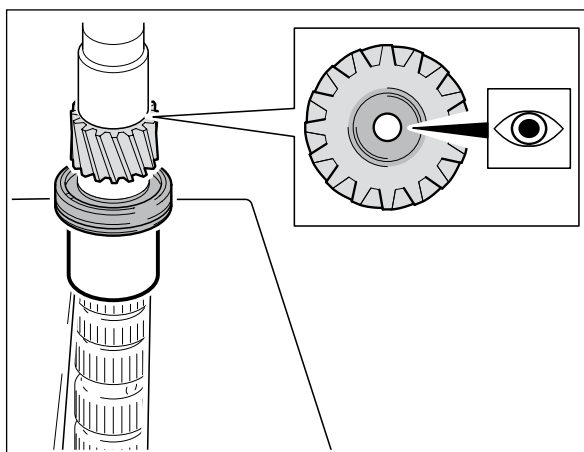

Fig. 61

- Mount snap ring [15]
- Mount first gear [14] on output shaft
- Mount snap ring [13]

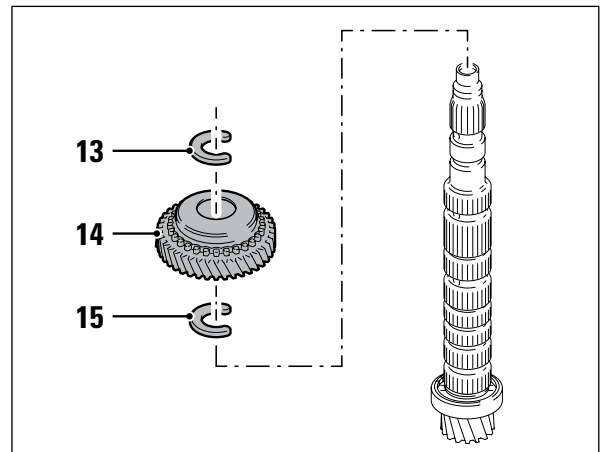

Fig. 62

- Mount synchro ring for first gear [12], synchro unit for first/second gear [11], synchro ring for second gear [10] and speed gear for second gear (9) on output shaft
- Mount snap ring [8]

Note:

Install synchronizer unit [11] with the groove (a) facing downwards.

Align the lugs of the synchro rings [10 and 12] in parallel to the detents of the synchronizer unit [11].

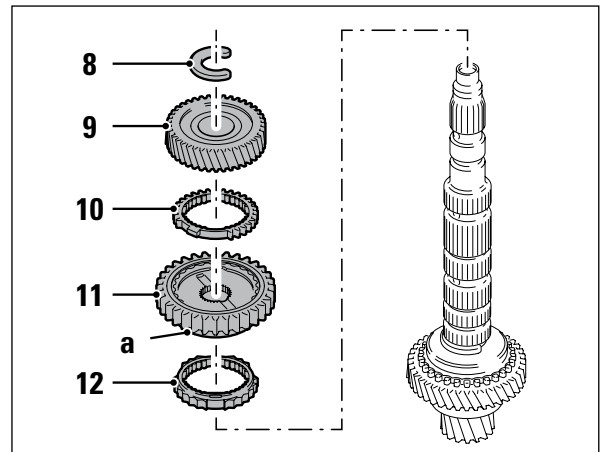

Fig. 63

- Mount third gear [7] on the output shaft
- Mount snap ring [6]

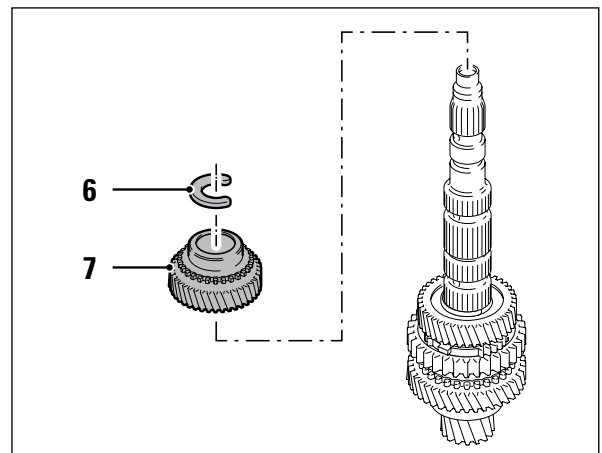

Fig. 64

- Mount synchro ring for third gear [5], synchro unit for third/fourth gear [4], synchro ring for fourth gear [3], fourth gear [2] and washer [1] on output shaft

Note:

Install synchronizer unit for third/fourth gear [4] with the groove (b) facing upwards.

Align the lugs of the synchro rings [3 and 5] in parallel to the detents of the synchronizer unit [4].

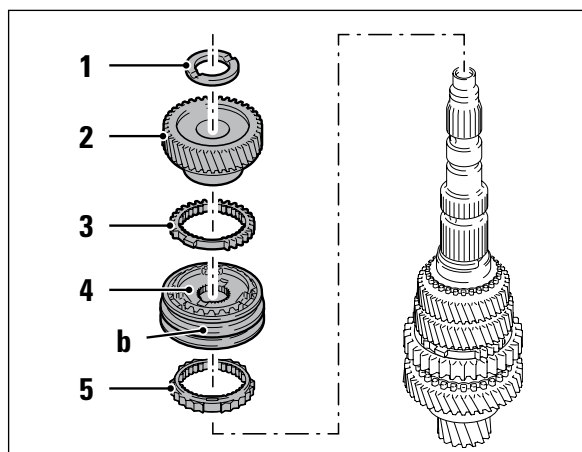

Fig. 65

- Press on the new bearing (4) of the output shaft with the groove facing upwards

Note:

During press-fitting, protect the lubrication connection against damage using a suitable sleeve.

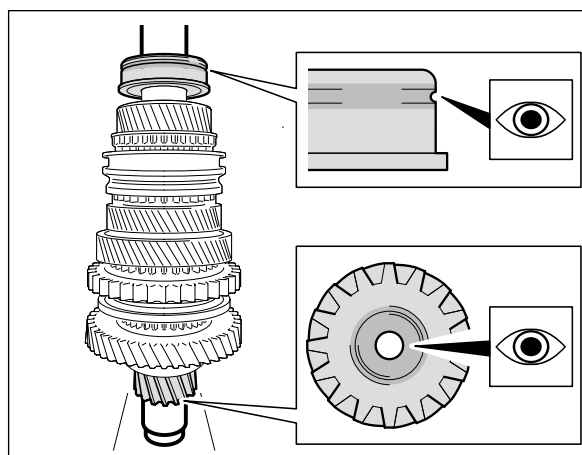

Fig. 66

- Clean sealing surfaces of the two halves of the housing
- Insert magnet [1]
- Mount detent [2] for the reverse gear shift fork incl. spring
- Insert the differential [3]

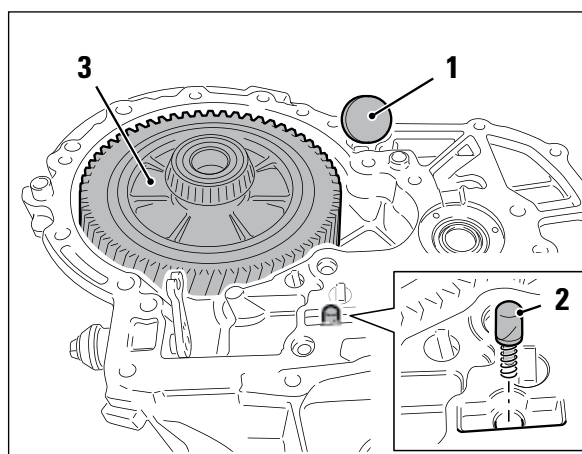

Fig. 67

- Clean the sealing surface of the intermediate plate [1]
- Apply sealant (e.g. Loctite 549) to the contact surface of the intermediate plate and the clutch cover
- Insert shift fork [2] through the hole in the intermediate plate
- Mount the intermediate plate
Tightening torque: 50 Nm

Note:

Remove excess sealant from the bearing seats and the holes in the shift fork shafts after tightening the intermediate plate bolts.

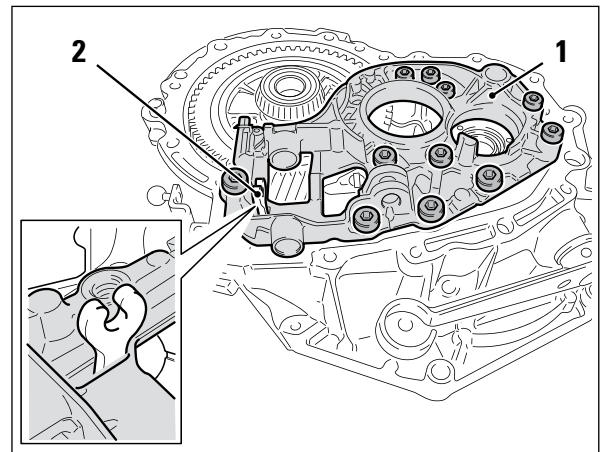

Fig. 68

- Slide the shift forks onto the selector sleeves of the synchronizer units
- Insert the drive shaft and output shaft including shifting mechanism into the transmission housing

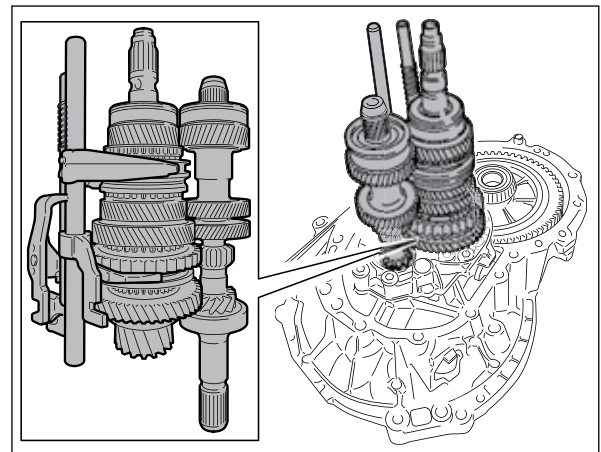

Fig. 69

- Assemble the shift finger [1] and locking clamp [2]

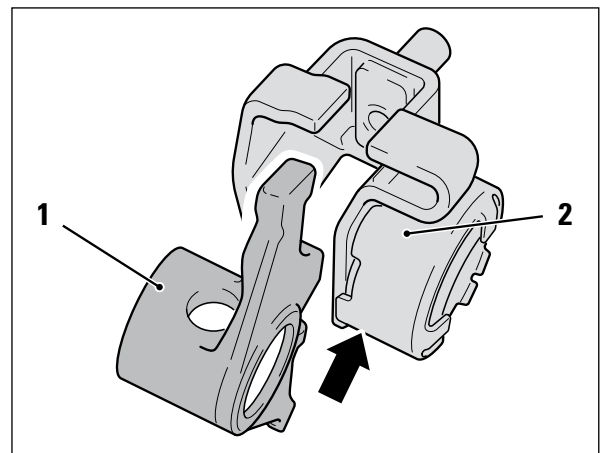

Fig. 70

- Install the shift finger and locking clamp

Note:

The fingers of the locking clamp must engage in the shifting claws of the shift rods.

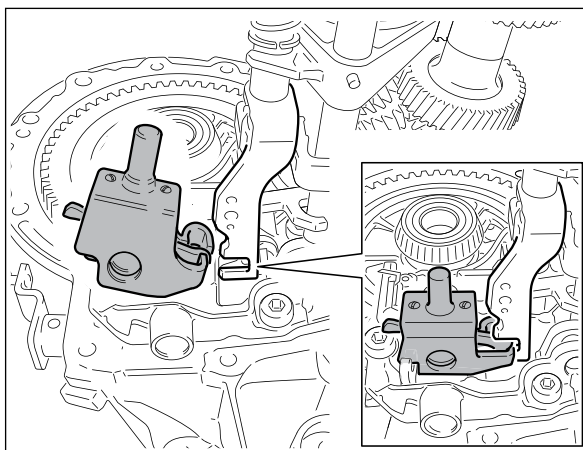

Fig. 71

- Insert locking clamp [1] into shift fork [2]

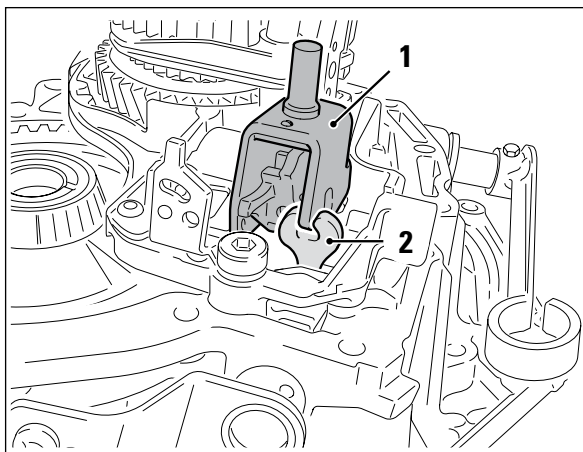

Fig. 72

- Insert spring for locking key

Note:

Wear protective goggles!

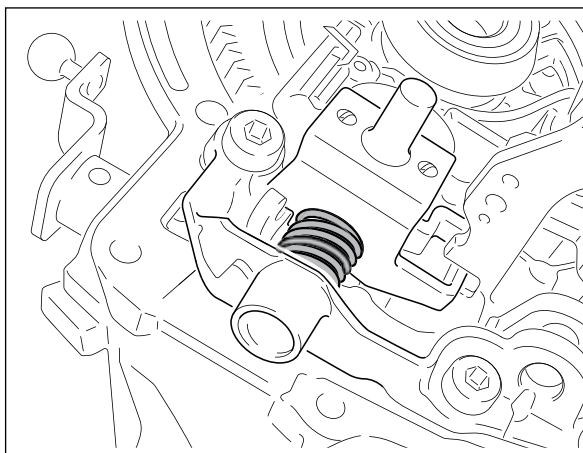

Fig. 73

- Mount selector shaft [1] with new shaft seal [2] (13)

Note:

Insert selector shaft until the dowel pin holes [3] of the shift finger and selector shaft are aligned.

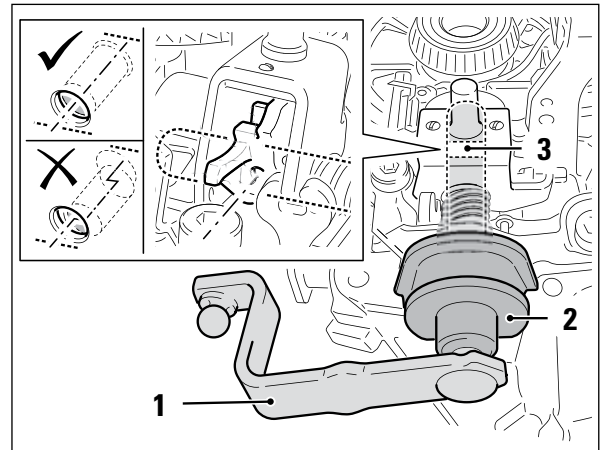

Fig. 74

- Connect the shift finger and selector shaft using the roll pin

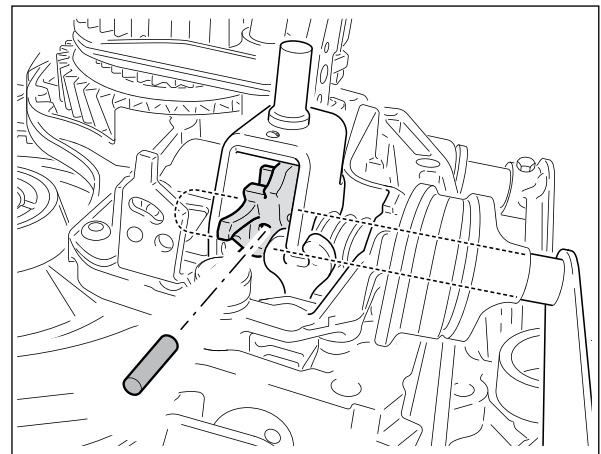

Fig. 75

- Mount the shift fork for reverse gear

Note:

Make sure that the reverse gear shift fork engages in the shift rod.

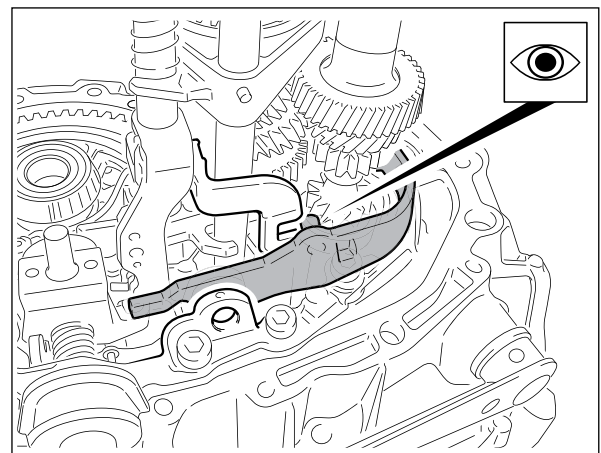

Fig. 76

- Install the bearing pin of the shift fork for reverse gear

Note:

Release the bearing pin by pressing on the shift fork.

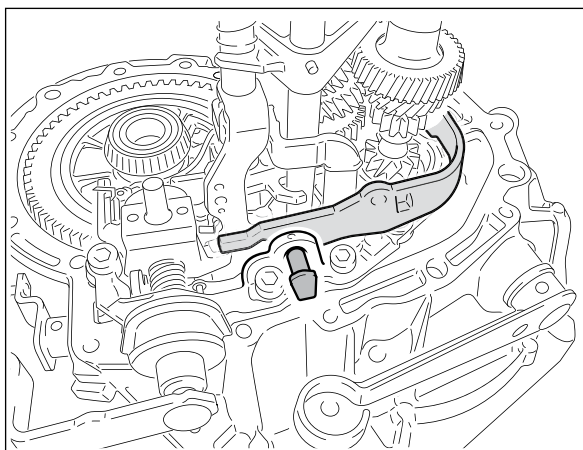

Fig. 77

- Insert reverse sliding gear [1]
- Insert the shaft for the reverse sliding gear [2]

Note:

Rotate the shaft of the reverse sliding gear until the lug (a) engages in the mounting slot of the housing.

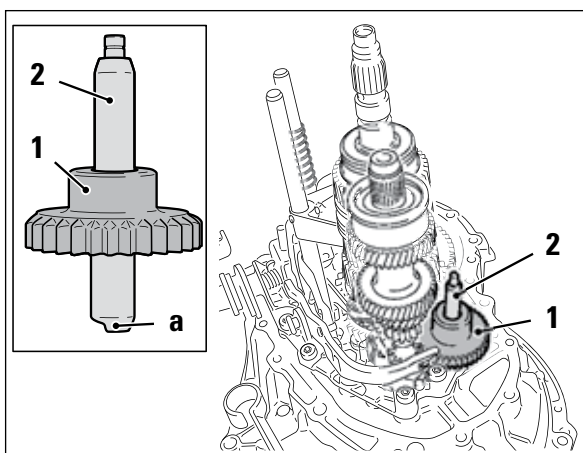

Fig. 78

Note:

For transmissions with reverse gear lock, make sure that the snap ring [1] and the spring [2] for reverse gear are present on the shift rod for first/second gear.

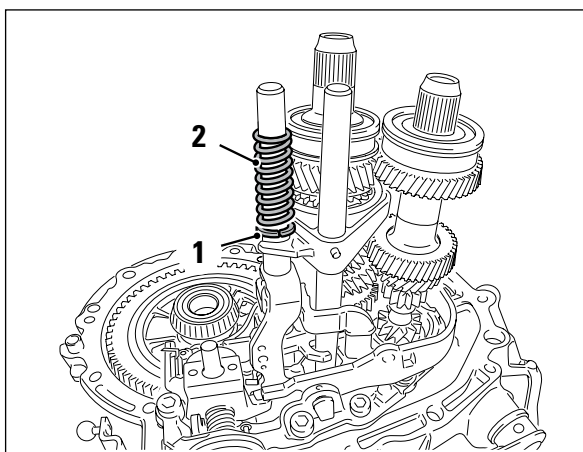

Fig. 79

- Align the seal [2] of the selector shaft
- Apply sealant (e.g. Loctite SI5135) evenly on the sealing surface of the clutch cover
- Position clutch control lever [1] vertically
- Attach the transmission housing

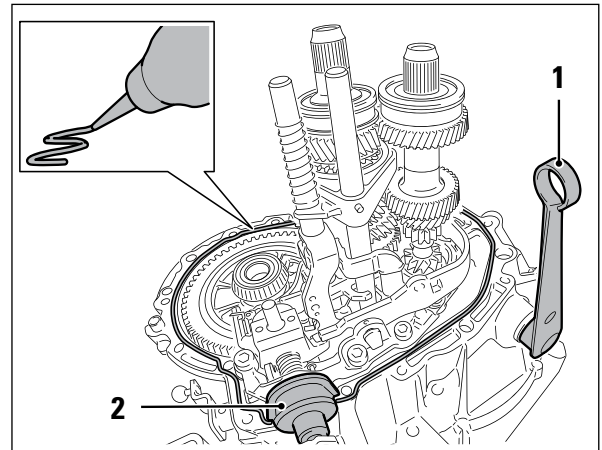

Fig. 80

- Insert housing bolts in accordance with the previous markings and tighten them evenly in a criss-cross pattern. Tightening torque: 23 Nm

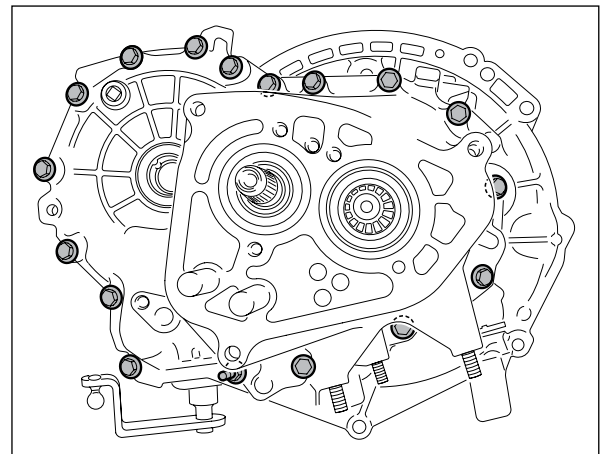

Fig. 81

- Insert the two bearing snap rings with the bevel (a) facing upwards
- Install the bolts of the bearing snap rings with thread-locking compound
Tightening torque: 18 Nm

Note:

To assist with installation of the bearing snap rings, lift the shafts slightly.

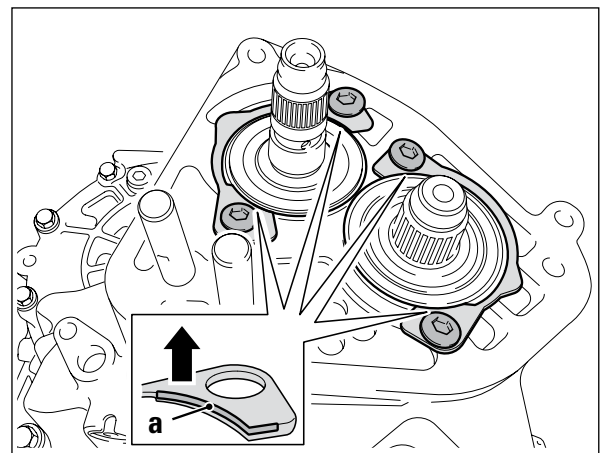

Fig. 82

- Mount the fixed gear for fifth gear

Note:

The high collar of the fixed gear must be facing upwards during assembly.

When press-fitting the gear wheel, the input shaft must be supported.

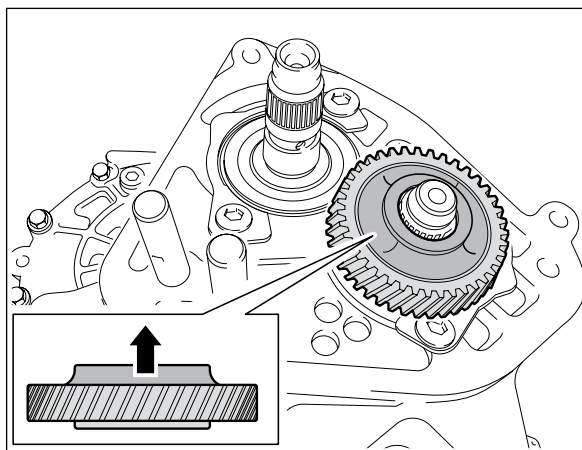

Fig. 83

- Insert spring washer [2] and new snap ring [1] (10)

Note:

Press the snap ring down firmly against the spring force of the washer with a suitable sleeve until it engages in the groove.

If necessary, use tongue-and-groove pliers to press further.

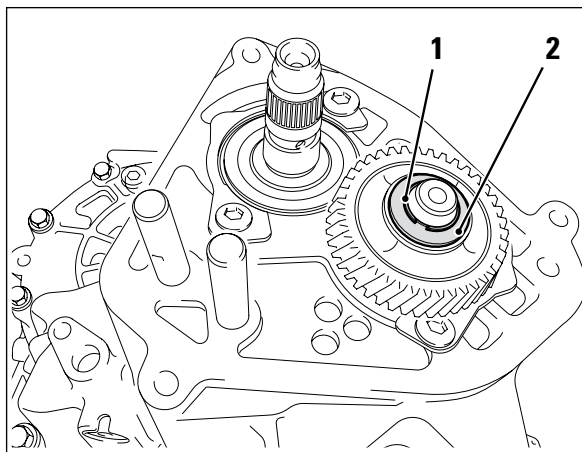

Fig. 84

- Mount the snap ring on the output shaft

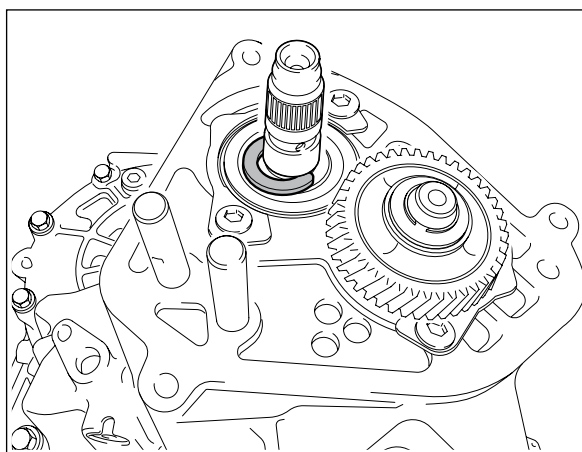

Fig. 85

- Mount synchronizer unit for fifth gear [1] together with the shift fork [2]

Note:

During installation, make sure that the shift fork [2] is pressed down evenly to prevent the synchronizer unit (balls, springs and detents) from falling apart.

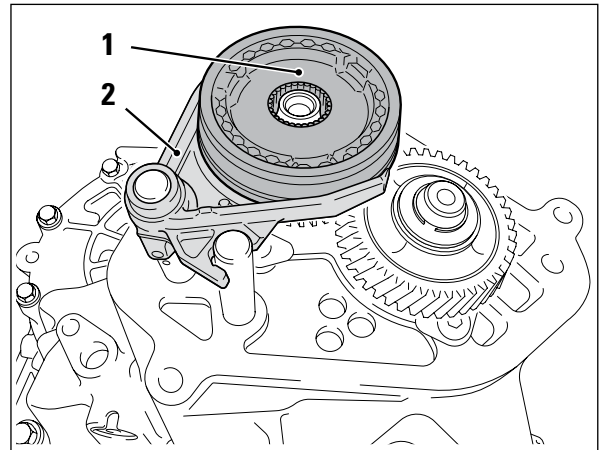

Fig. 86

- Mount support washer [2] and new snap ring [1] (11)

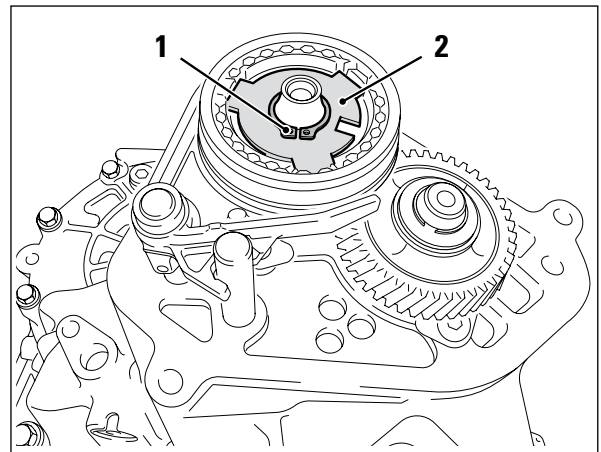

Fig. 87

- Secure shift fork for fifth gear with a new spring pin (12)

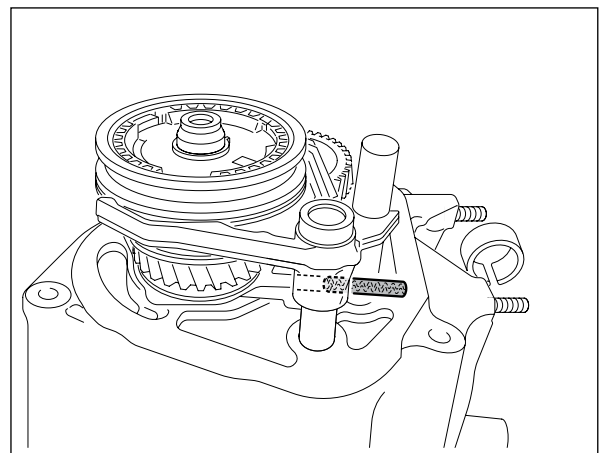

Fig. 88

- Clean the sealing surface of the transmission cover
- Replace the seal (15) of the transmission cover

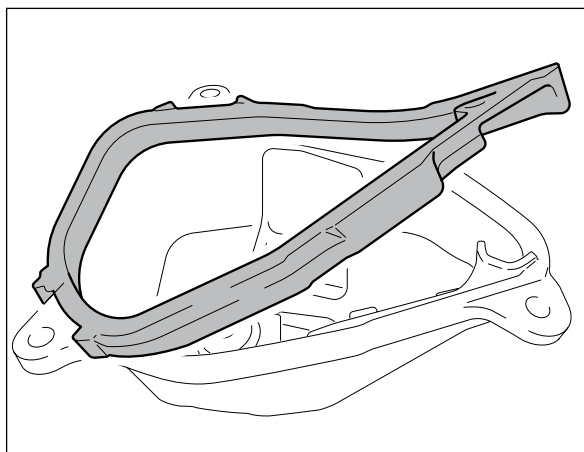

Fig. 89

- Clean the sealing surface of the transmission housing
 - Mount the cover for the transmission housing and tighten the bolts
- Tightening torque 22 Nm

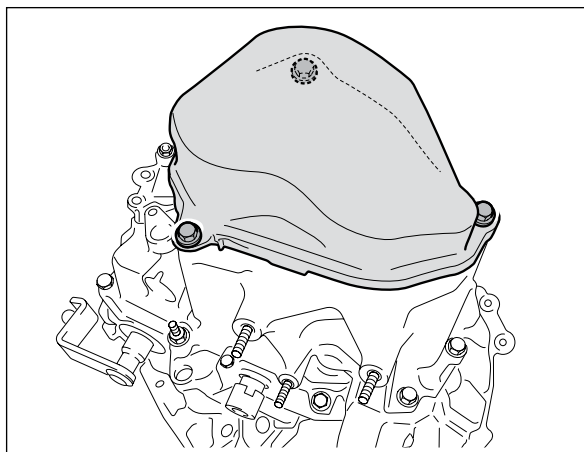

Fig. 90

- Mount the new guiding sleeve (14) incl. flanged shaft seal and tighten the bolts
- Tightening torque: 10 Nm

Note:

The three mounting bolts protrude into the transmission housing. Apply sealant (e.g. Loctite 243) to the mounting bolts before assembly.

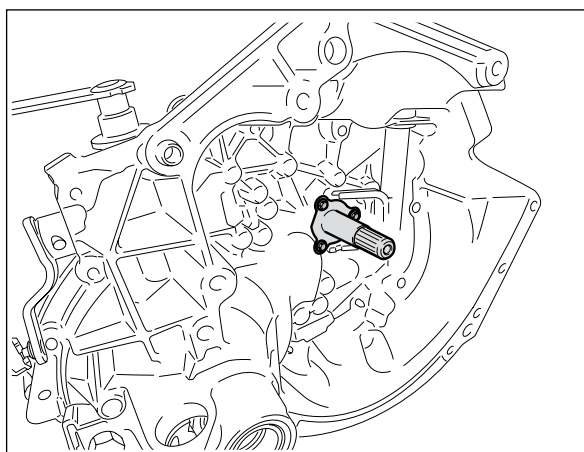

Fig. 91

- Install reversing light switch [1]
Tightening torque: 25 Nm
- Replace the sealing ring (9) of the speedometer shaft [2] and then mount the tachometer shaft
Tightening torque: 10 Nm

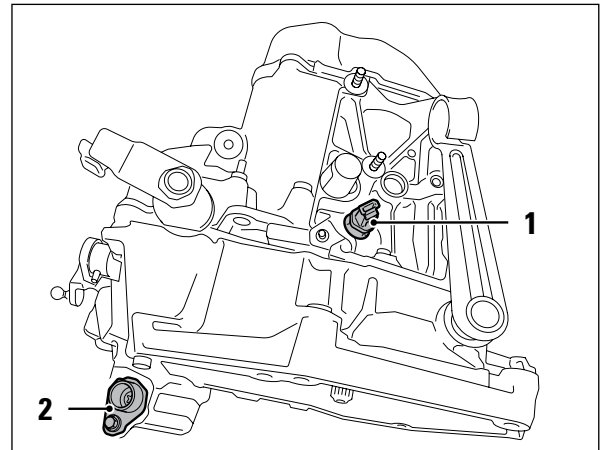

Fig. 92

- Remove the end cover from the breather hole
- Fill the empty transmission via the breather hole according to the vehicle manufacturer's specifications
- Mount the end cover on the breather hole

Note:

The vehicle manufacturer recommends
ESSO 75W80 EZL 848 or
TOTAL 75W80 H 6965.

- Install transmission according to vehicle manufacturer's specifications

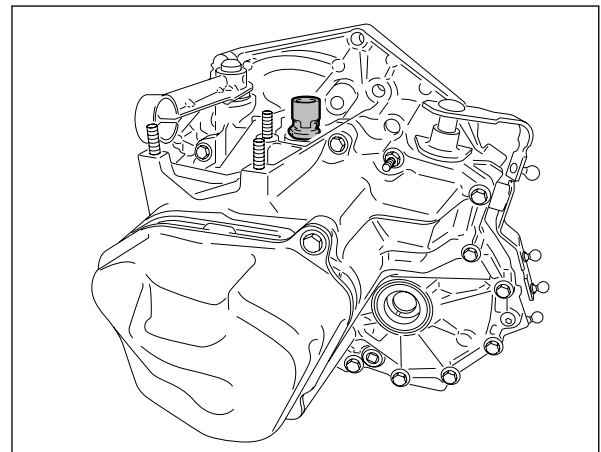

Fig. 93

More garage knowledge:
www.rexpert.com