



VKPC 95898

Technical Bulletin - March 2011



HYUNDAI Elantra, i20, i30, i30 CW Estate
KIA Carens II, Cerato, CEE'D Hatchback, CEE'D Estate, SOUL



OE/SKF DESIGN EVOLUTION
VKPC 95872 is replaced by VKPC 95898



OE #: HYUNDAI / KIA 25100 2B000 replaced by 25100-2B700.

| CAR MAKER | MODEL | ENGINE | ENGINE CODES |
|-----------|---|----------|------------------|
| HYUNDAI | Elantra, i20, i30, i30 CW Estate | 1.4, 1.6 | G4ED-G, G4GA, |
| KIA | Carens II, Cerato, CEE'D Hatchback, CEE'D Estate, SOUL | 1.4, 1.6 | G4FC, G4FA, G4ED |

HYUNDAI OE has changed the design of water pump on the early car models.

HYUNDAI stopped the supply of the old waterpump, equivalent to VKPC 95872 which is used in applications from year 2000-2006. HYUNDAI recommends replacing the old waterpump to the new evolved design + fitting a new pulley, ensuring the proper belt alignment and fitting is maintained.

To follow car makers' specifications, SKF offers the equivalent waterpump together with the pulley to cover for the old application as per Hyundai instructions.



OLD DESIGN

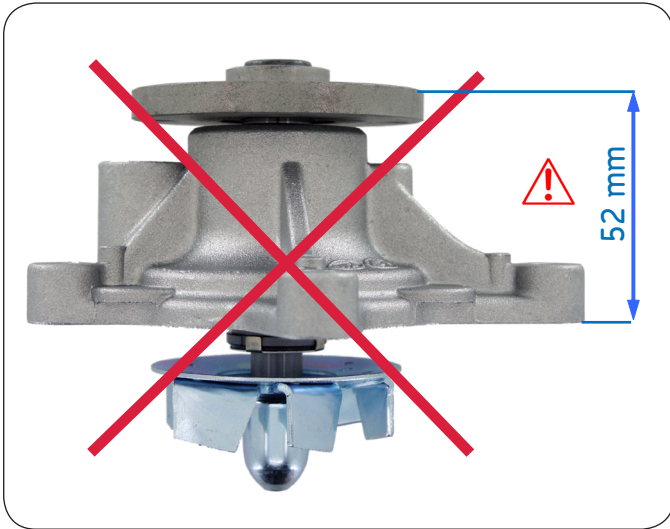

NEW DESIGN

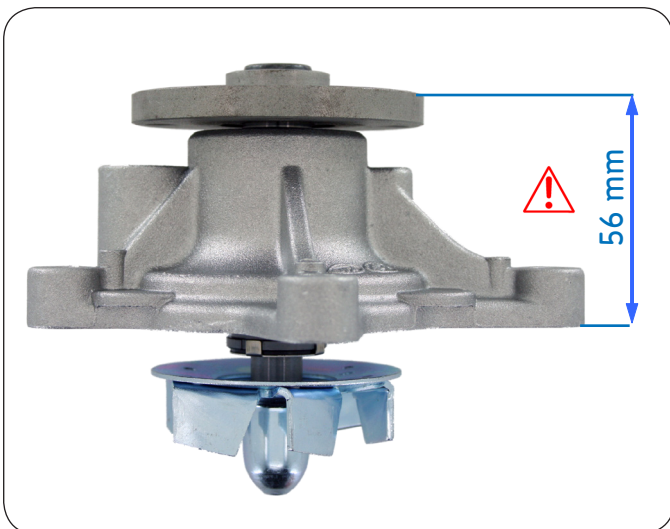

PULLEY NEW DESIGN



+



New pulley required
to ensure correct belt
alignment

© SKF is a registered trademark of the SKF Group.

© SKF Group 2011
The contents of this publication are the copyright of the publisher and may not be reproduced (even extracts) unless prior written permission is granted. Every care has been taken to ensure the accuracy of the information contained in this publication but no liability can be accepted for any loss or damage whether direct, indirect or consequential arising out of the use of the information contained herein.