

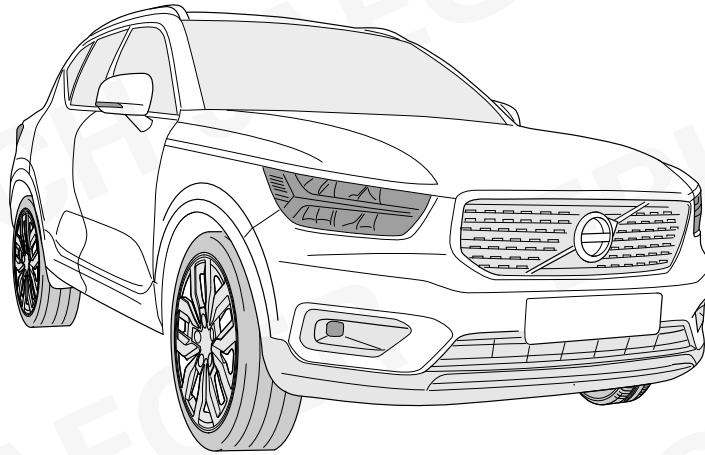

ERICH JAEGER



VOLVO XC40

03/18 >>

VOLVO XC40 Recharge (PHEV)

06/20 >>

748303

Für aktuellste Version scannen
Scan for current version

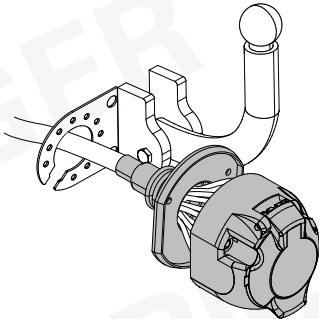

13-PIN

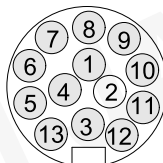

ISO 11446



- (D) Einbauanleitung
- (GB) Installation instructions
- (F) Consignes de montage
- (NL) Montagehandleiding
- (DK) Montagevejledning
- (N) Monteringsinstruksjon
- (S) Installationsanvisning
- (FIN) Asennusohje
- (I) Istruzioni per il montaggio
- (E) Instrucciones de montaje
- (P) Instruções de montagem
- (GR) Οδηγίες εγκατάστασης
- (CZ) Návod k montáži

- (PL) Instrukcja montażu
- (TR) Montaj talimatı
- (H) Beépítési útmutató
- (HR) Upute o ugradnji
- (BUL) Инструкция за монтаж
- (RO) Instrucțiuni de montaj
- (RU) Инструкция по монтажу и установке
- (LT) Montavimo informacija
- (LV) Iemontēšanas pamācība
- (EST) Paigaldusjuhend
- (SLO) Navodilo za vgradnjo
- (SK) Montážny návod



OVERVIEW

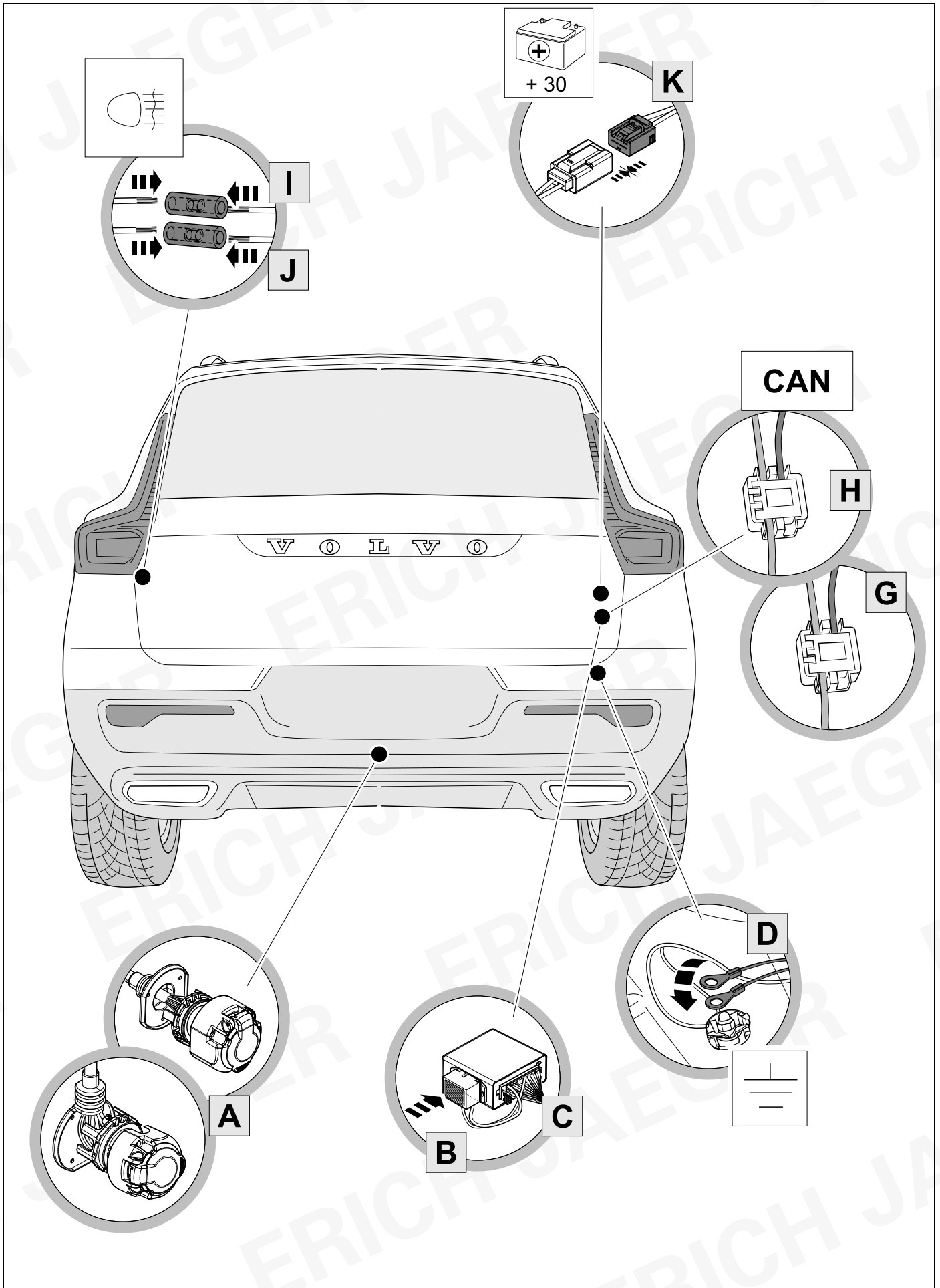

KIT

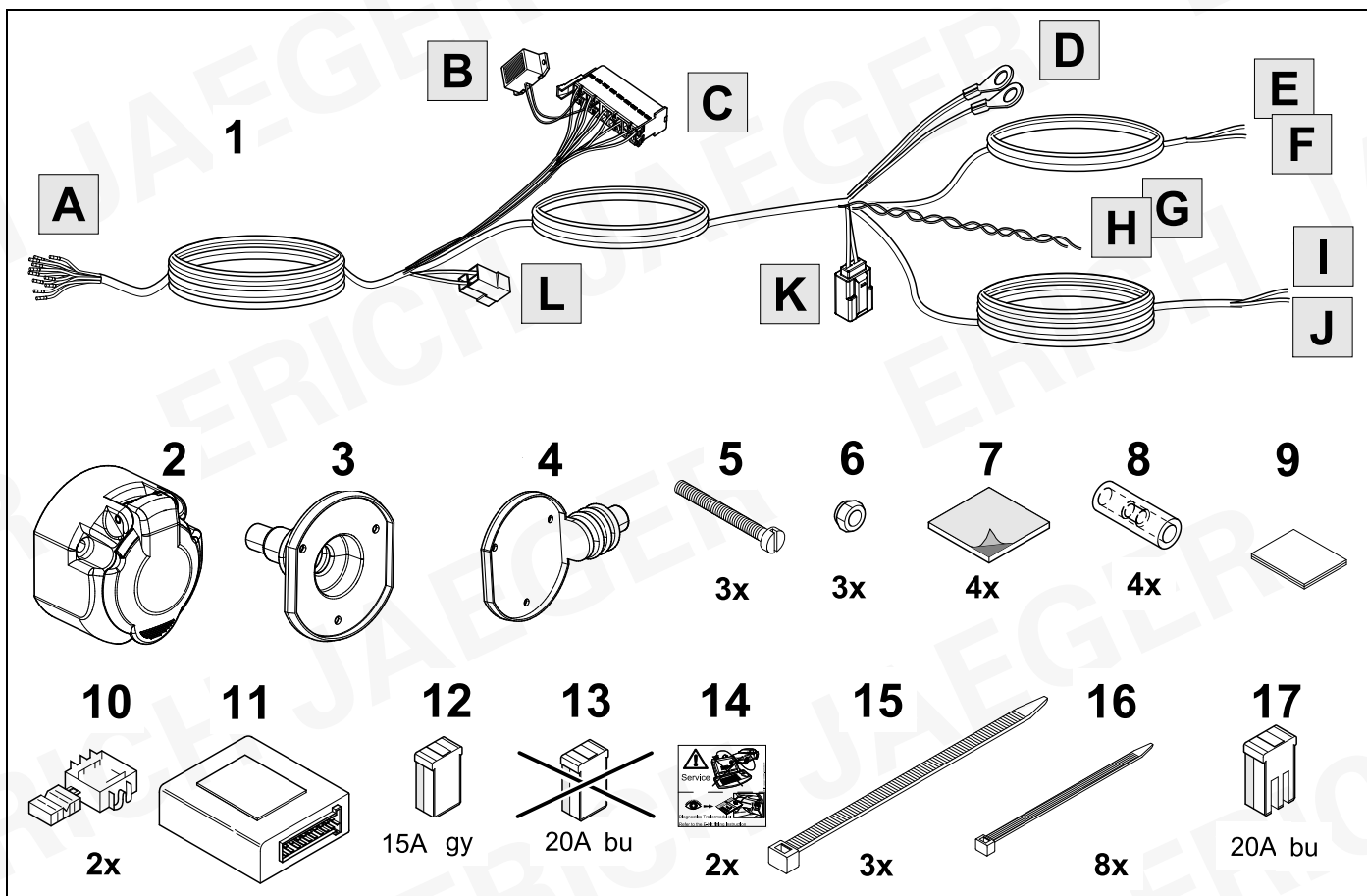

TOOLS

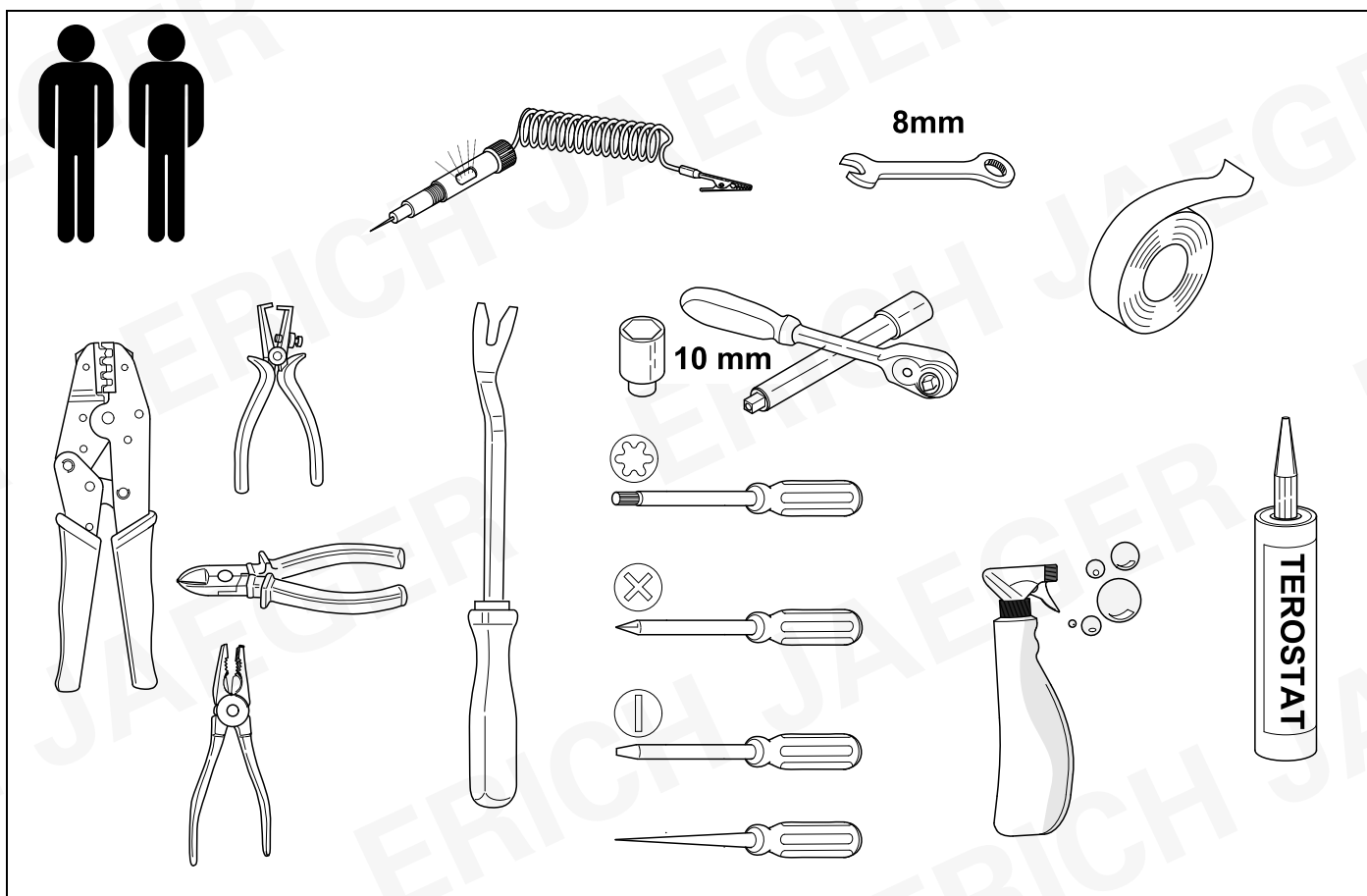

1

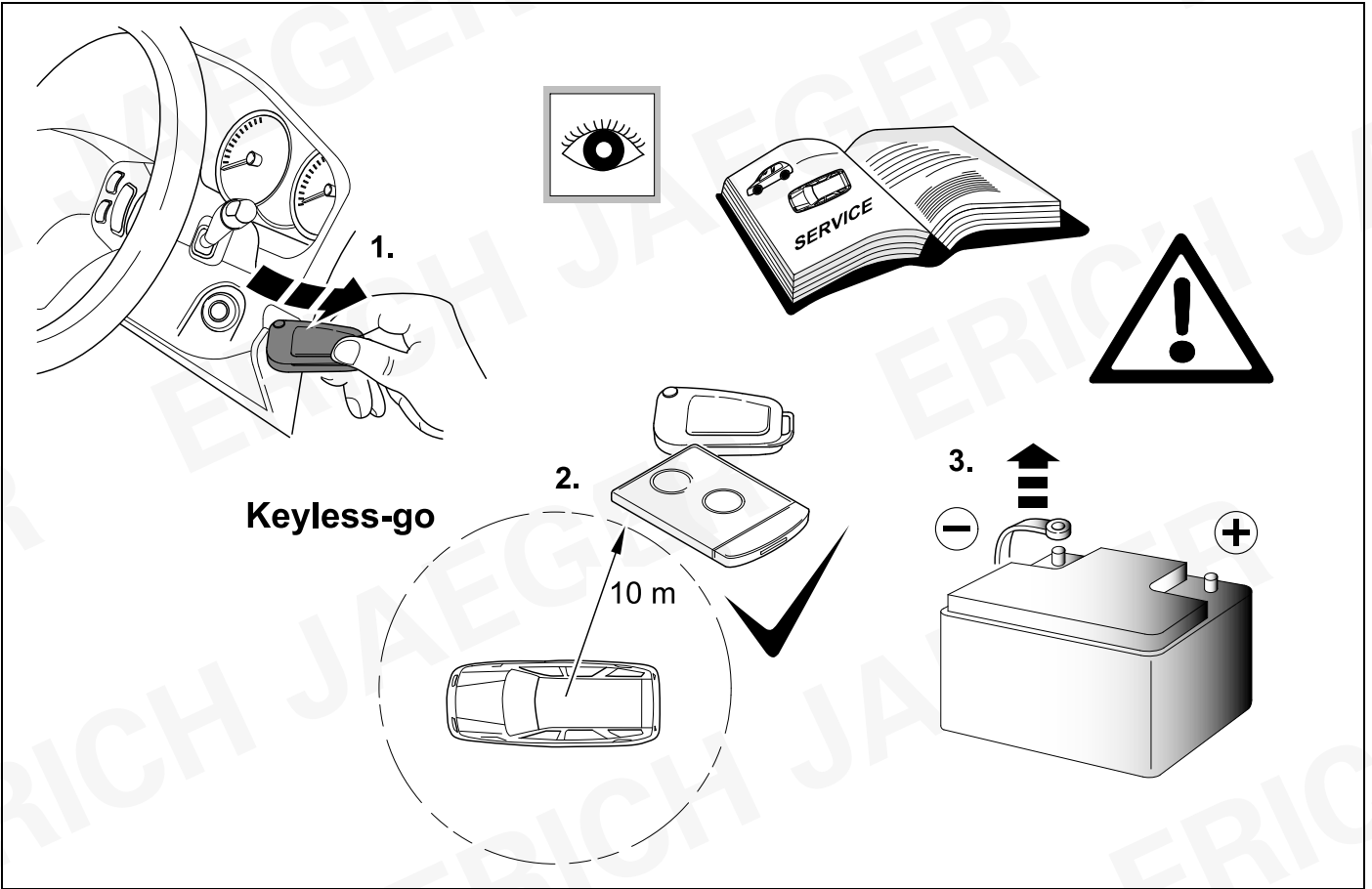

2 REMOVE

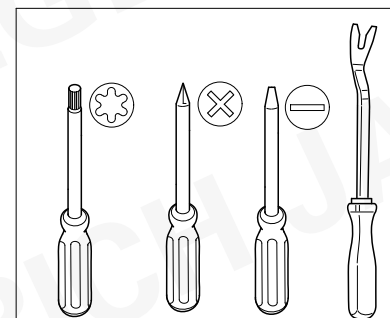
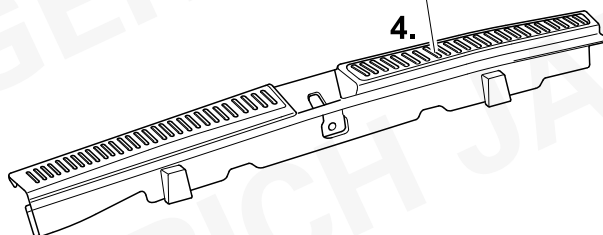
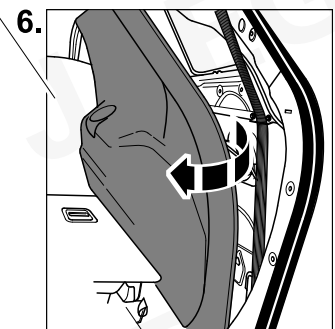
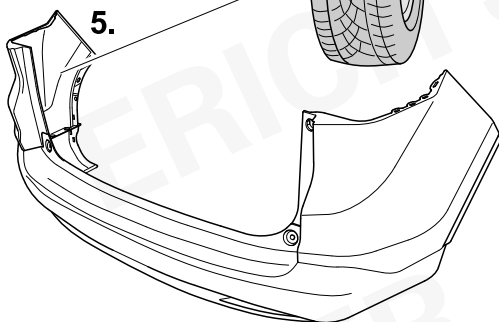
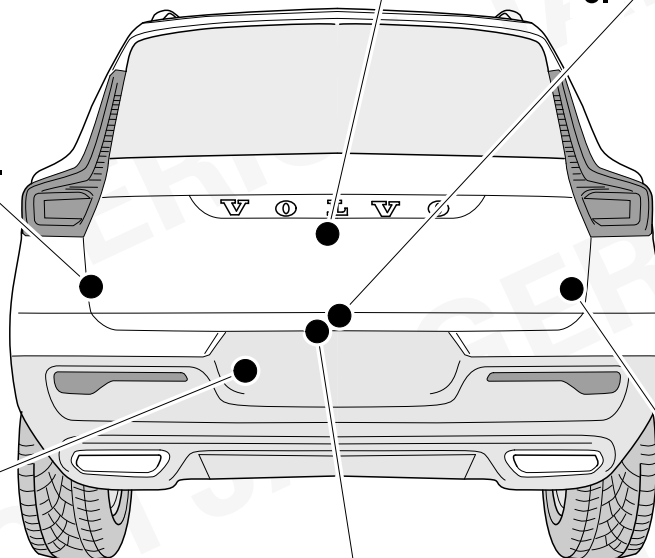
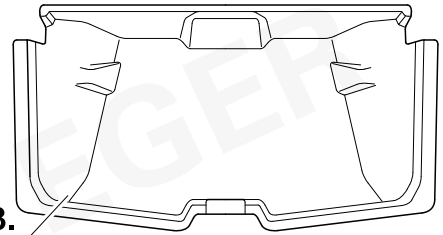
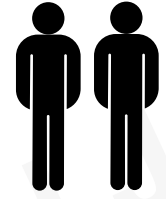
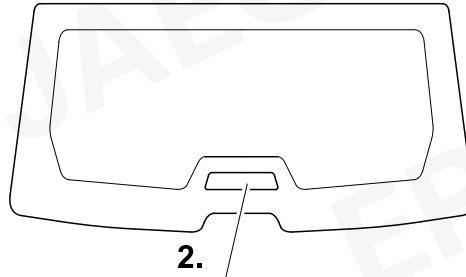
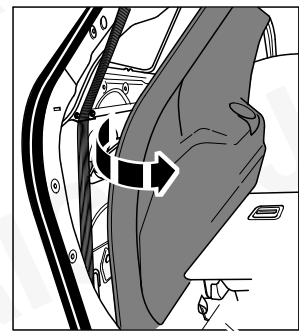
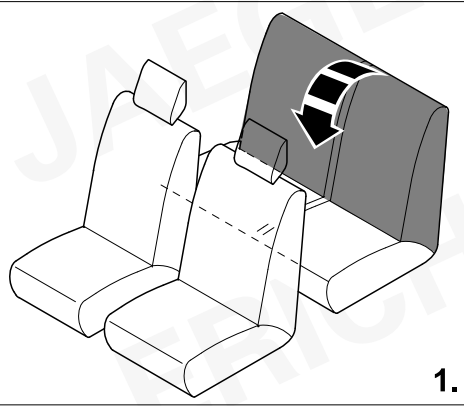

3

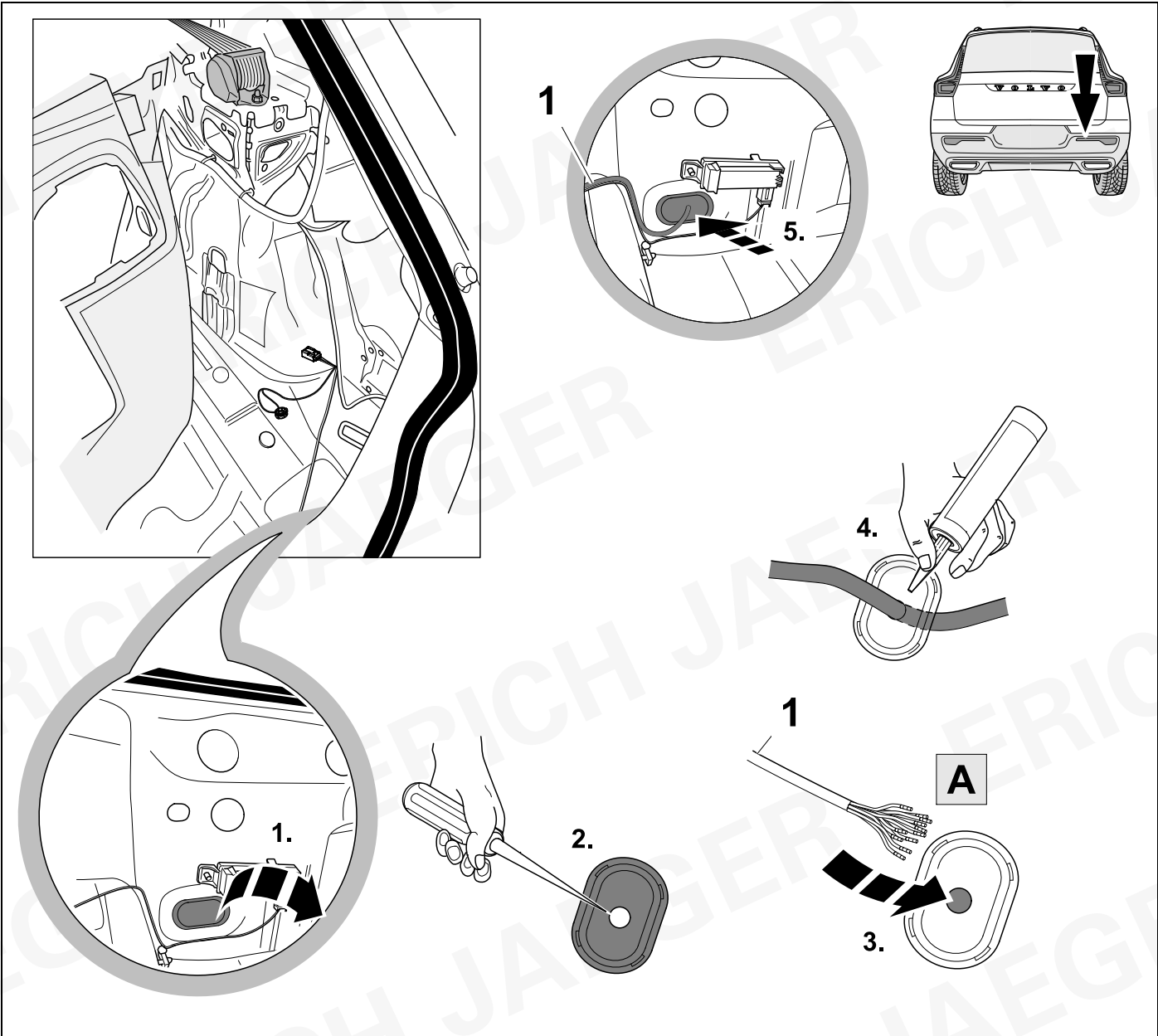

4

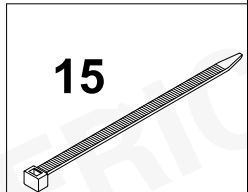
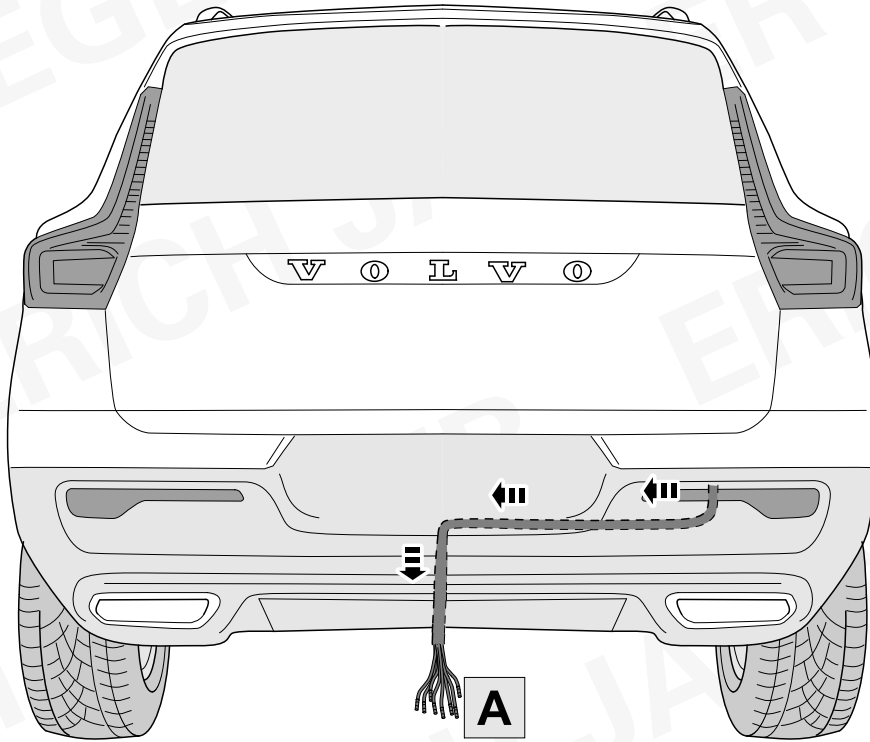

5

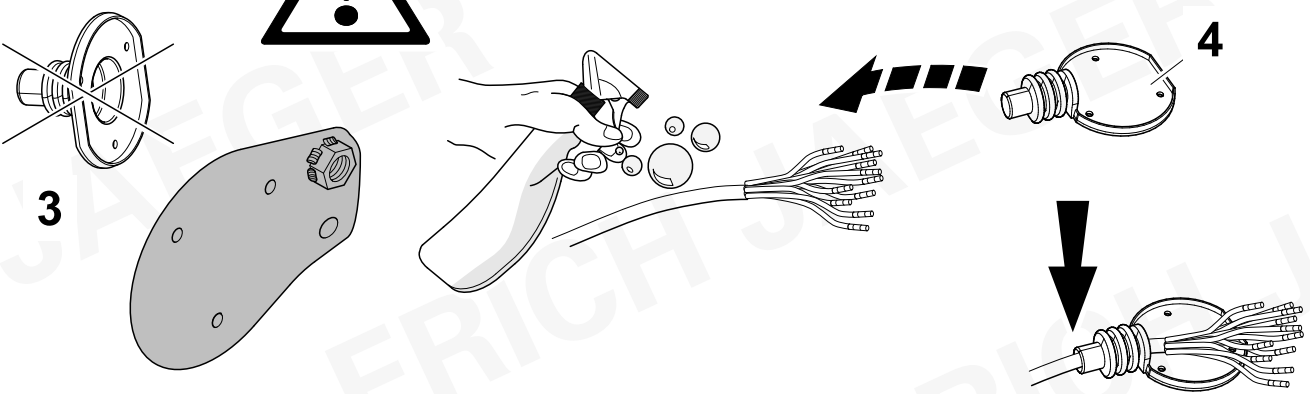
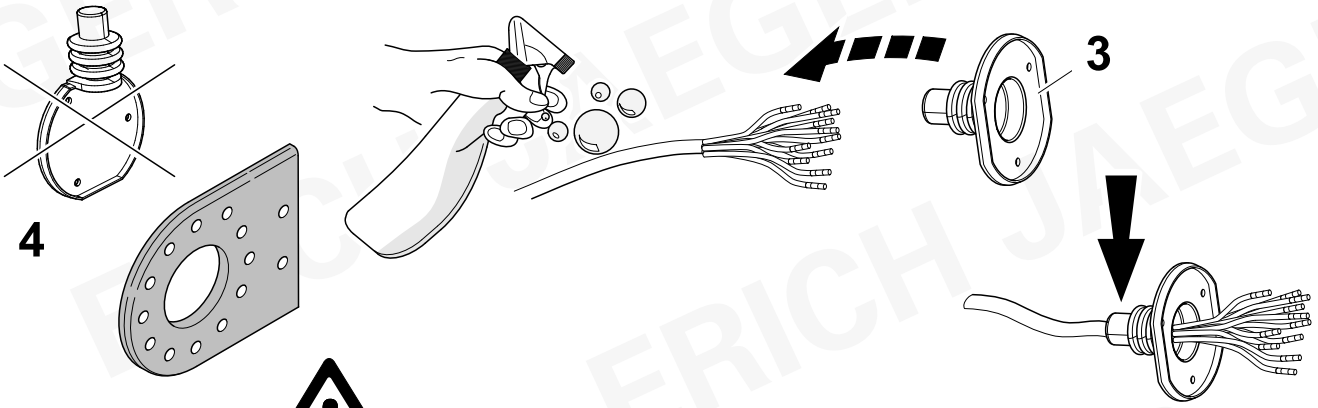

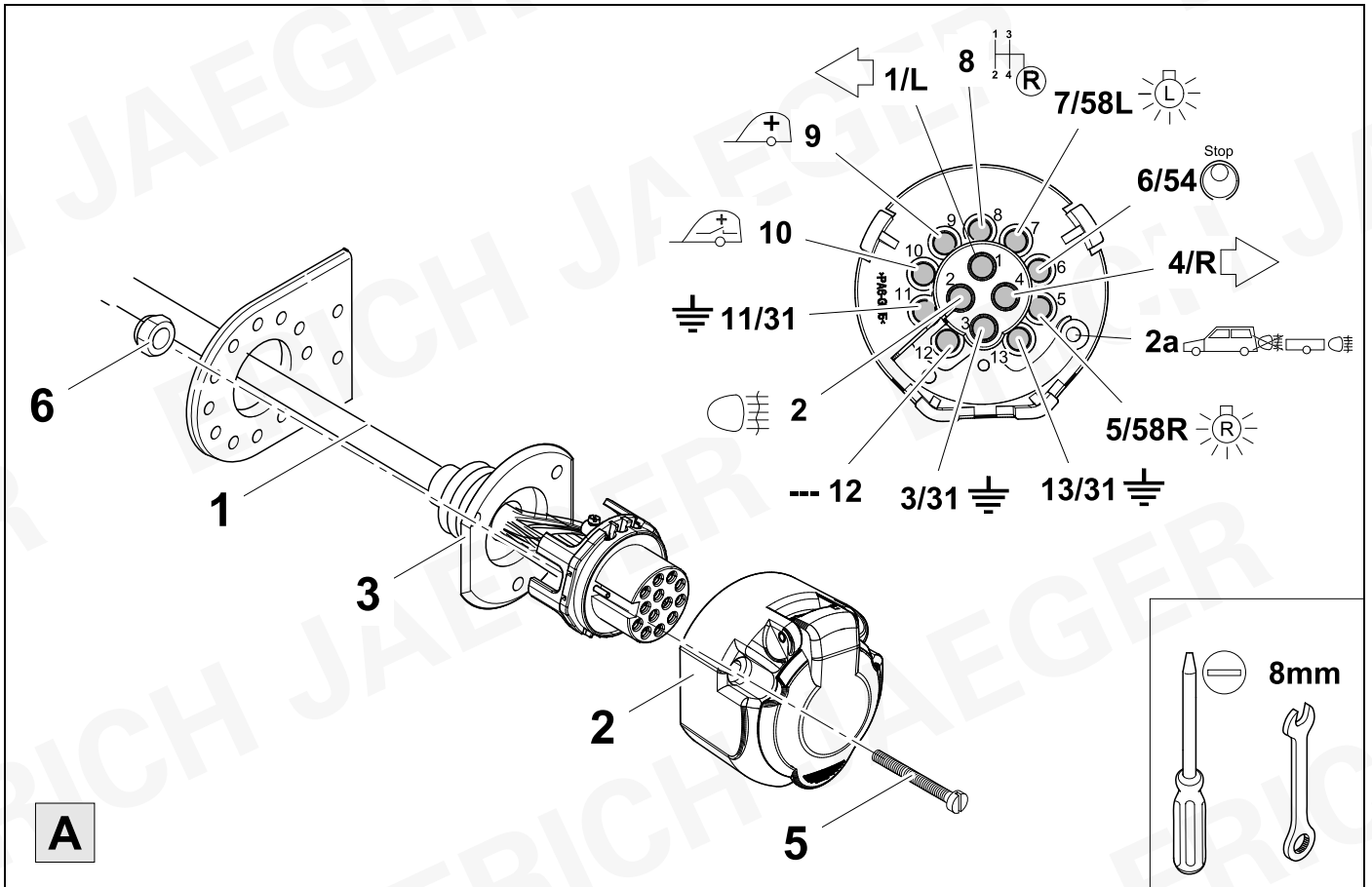
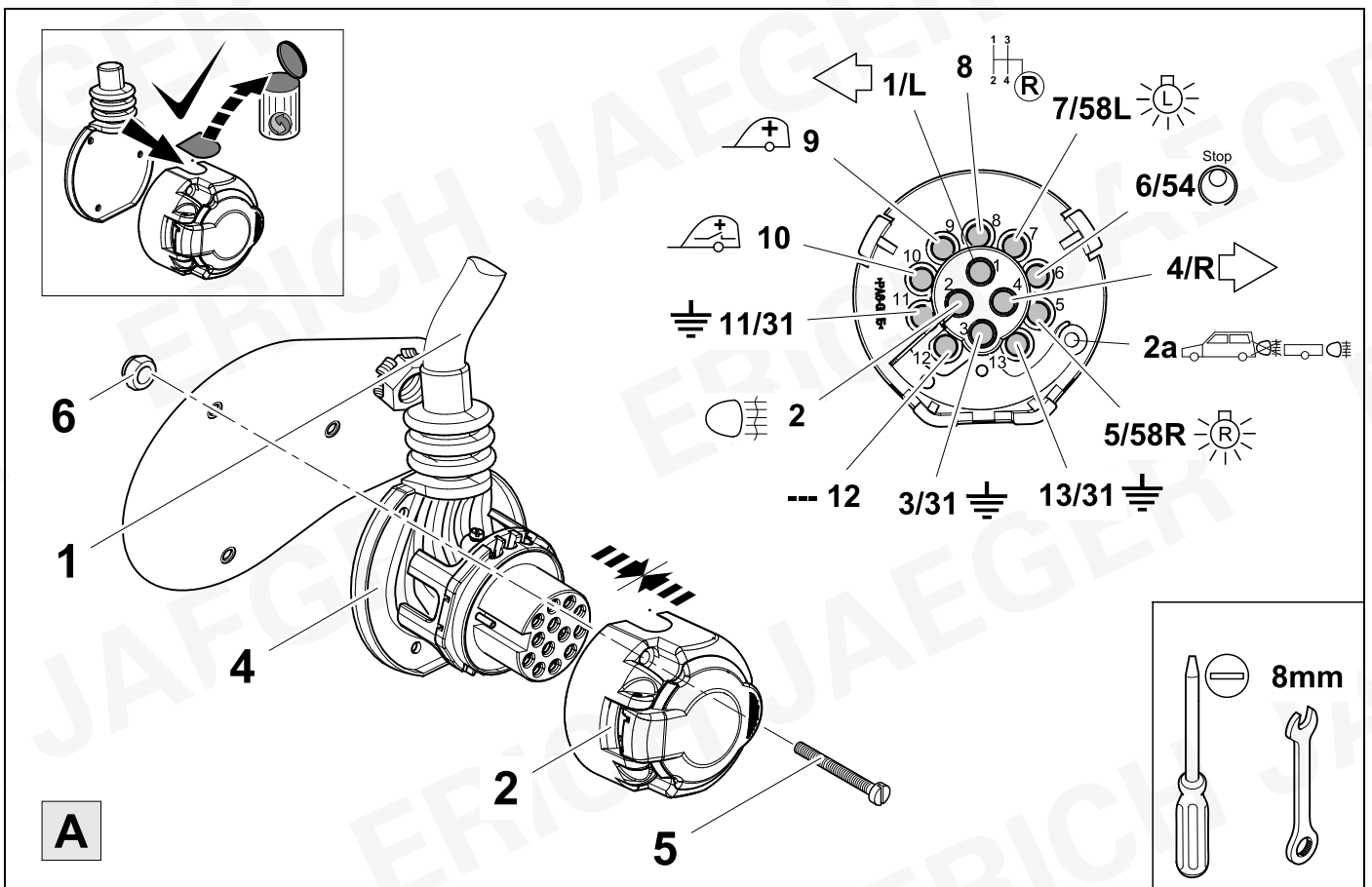
6**8****A****7****8****A**

8



9

1	bk/wh		8	bu/rd	
2	gy		9	rd	
3	wh/bn		10	ye	
4	bk/gn		11	bn/gn	
5	gy/rd		12	no	
6	bk/rd		13	bn	
7	gy/bk		58b/2a	gy/wh	

9	bk	wh	gy	gn	rd	bu	ye	bn	pu	or	no
D	schwarz	weiß	grau	grün	rot	blau	gelb	braun	violett	orange	nicht belegt
GB	black	white	grey	green	red	blue	yellow	brown	purple	orange	not occupied
F	noir	blanc	gris	vert	rouge	bleu	jaune	brun	violet	orange	inutilisé
NL	zwart	wit	grijs	groen	rood	blauw	geel	bruin	violet	oranje	niet aangesloten
DK	sort	hvid	grå	grøn	rød	blå	gul	brun	violet	orange	ikke anvendt
N	svart	hvit	grå	grønn	rød	blå	gul	brun	fiolett	oransje	ikke i bruk
S	svart	vit	grå	grön	röd	blå	gul	brun	violett	orange	ej använd
FIN	musta	valkoinen	harmaa	vihreä	punainen	sininen	keltainen	ruskea	violetti	oranssi	ei varattu
I	nero	bianco	grigio	verde	rosso	blu	giallo	marrone	viola	arancione	libero
E	negro	blanco	gris	verde	rojo	azul	amarillo	marrón	violeta	anaranja-do	no ocupado
P	preto	branco	cinzento	verde	vermelho	azul	amarelo	castanho	violeta	laranja	não ocupado
GR	μαύρος	λευκός	Γκρι	πράσινος	κόκκινος	μπλε	κίτρινος	καφέ	Μωβ	πορτοκαλί	δεν είναι κατ'επιτημένος
PL	czarny	biały	szary	zielony	czerwony	niebiesko	żółty	brazowy	fioletowy	pomarańczowy	wolny
CZ	černý	bílý	šedý	zelený	červený	modrý	žlutý	hnědý	fialový	oranžový	neobsazen
TR	siyah	beyaz	gri	yeşil	kırmızı	mavi	sarı	kahverengi	mor	portakal rengi	boş
H	fekete	fehér	szürke	zöld	piros	kék	sárga	barna	ibolyakék	narancssárga	nem foglalt
HR	crno	bijelo	sivo	zeleno	crveno	plavo	zuto	smeđe	ljubičasto	narandasto	nije zauzeto
BUL	черен	бял	сив	зелен	червен	син	жълт	кафяв	виолетов	оранжев	свободно
RO	negru	alb	gri	verde	roșu	albastru	galben	maro	violet	portocaliu	liber
RU	черный	белый	серый	зеленый	красный	голубой	жёлтый	коричневый	пурпурный	оранжевый	свободно
LT	juoda	balta	pilka	žalia	raudona	mėlyna	geltona	ruda	purpurinė	oranžinė	laisva
LV	melna	balta	pelēka	zaļa	sarkana	zila	dzeltena	brūna	purpur-sarkana	oranža	brīvs
EST	must	valge	hall	roheline	punane	sinine	kollane	pruun	purpur-punane	oraanž	vaba
SLO	črna	bela	siva	zelena	rdeča	modra	rumena	smeđ	vijoličast	oranžen	ni zasedeno
SK	čierny	biely	šedý	zelený	červený	modrý	žltý	hnědý	fialový	pomaraňový	neobsadený

10



9

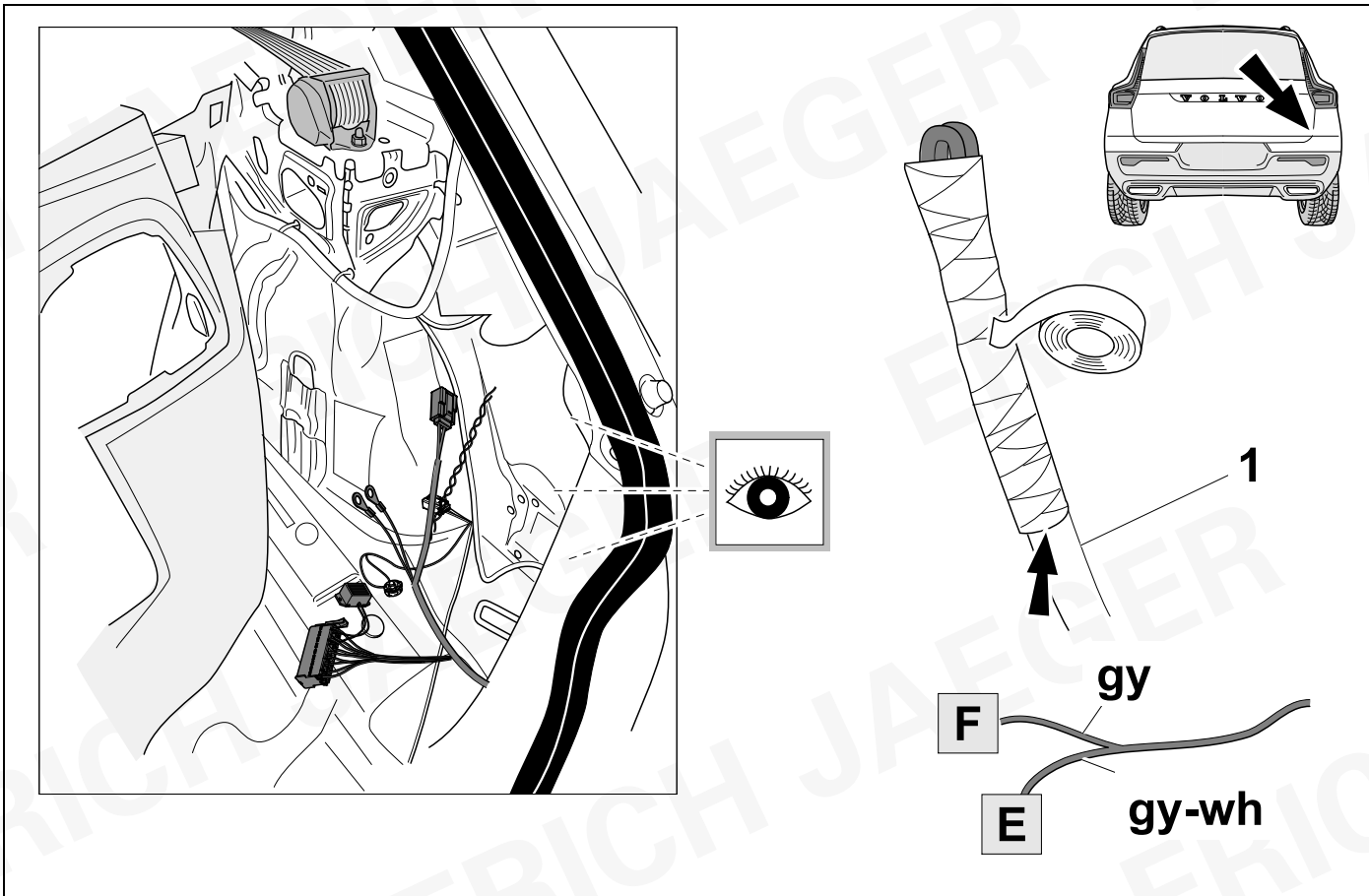

11

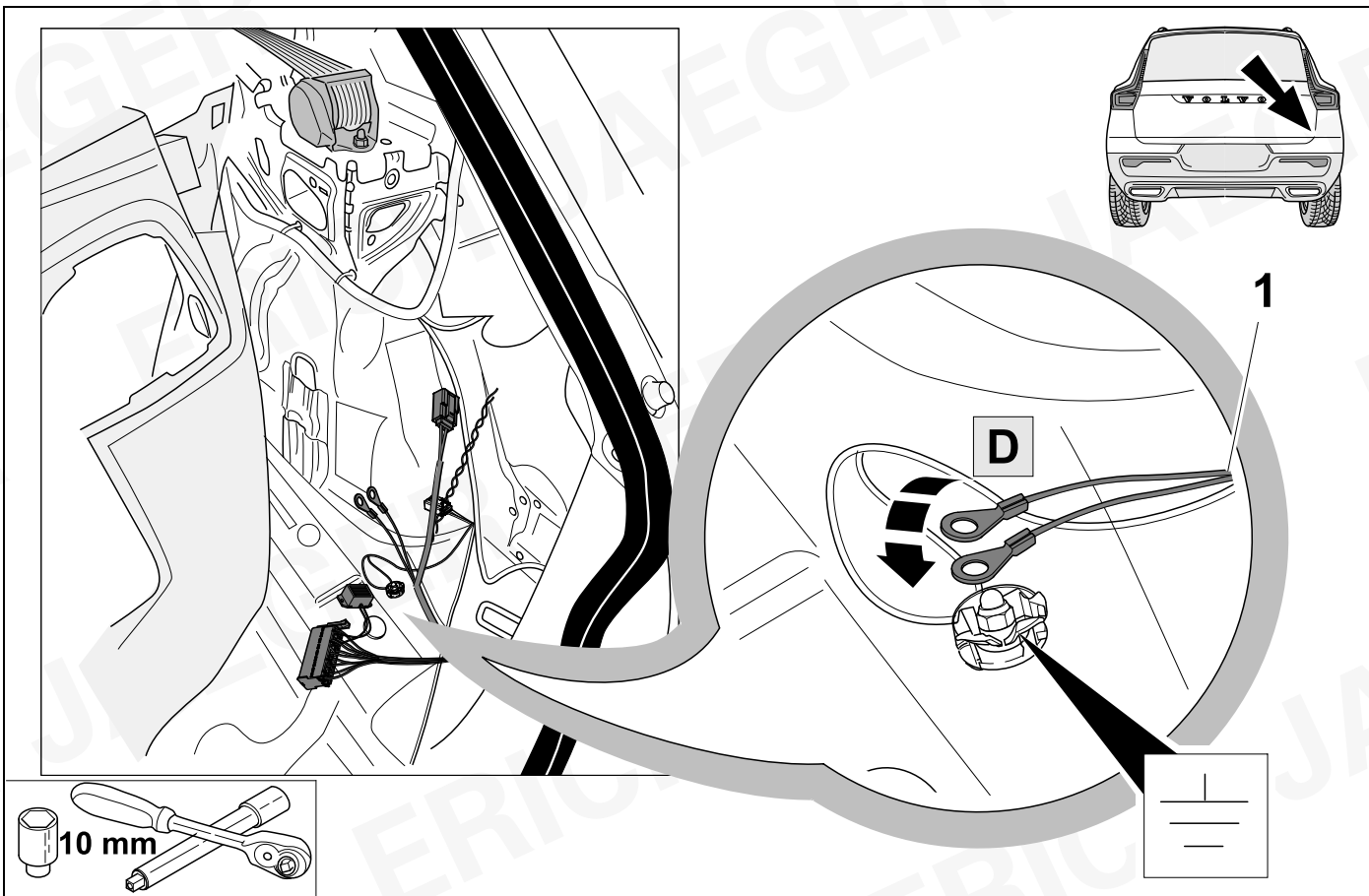

12

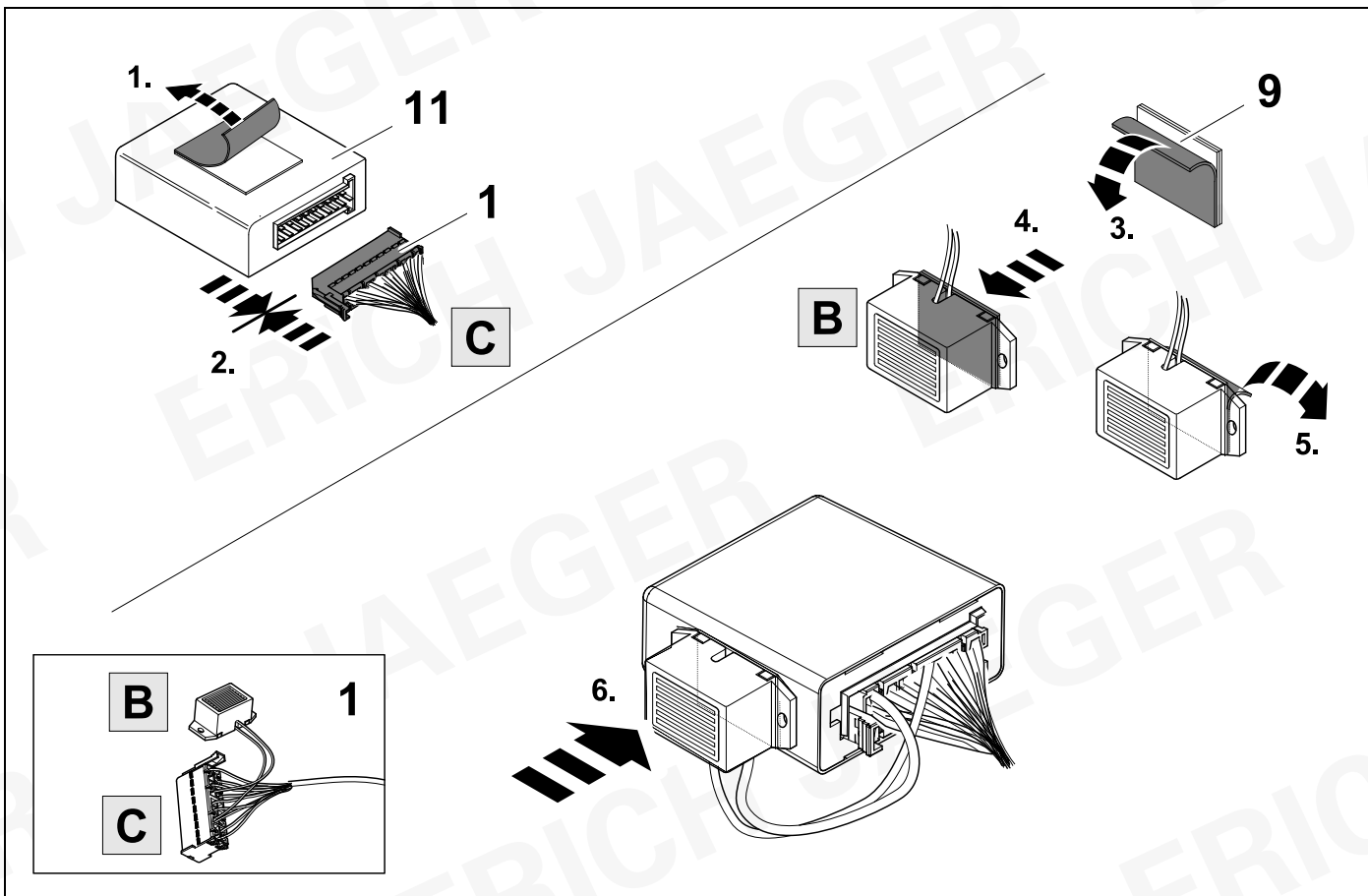

13

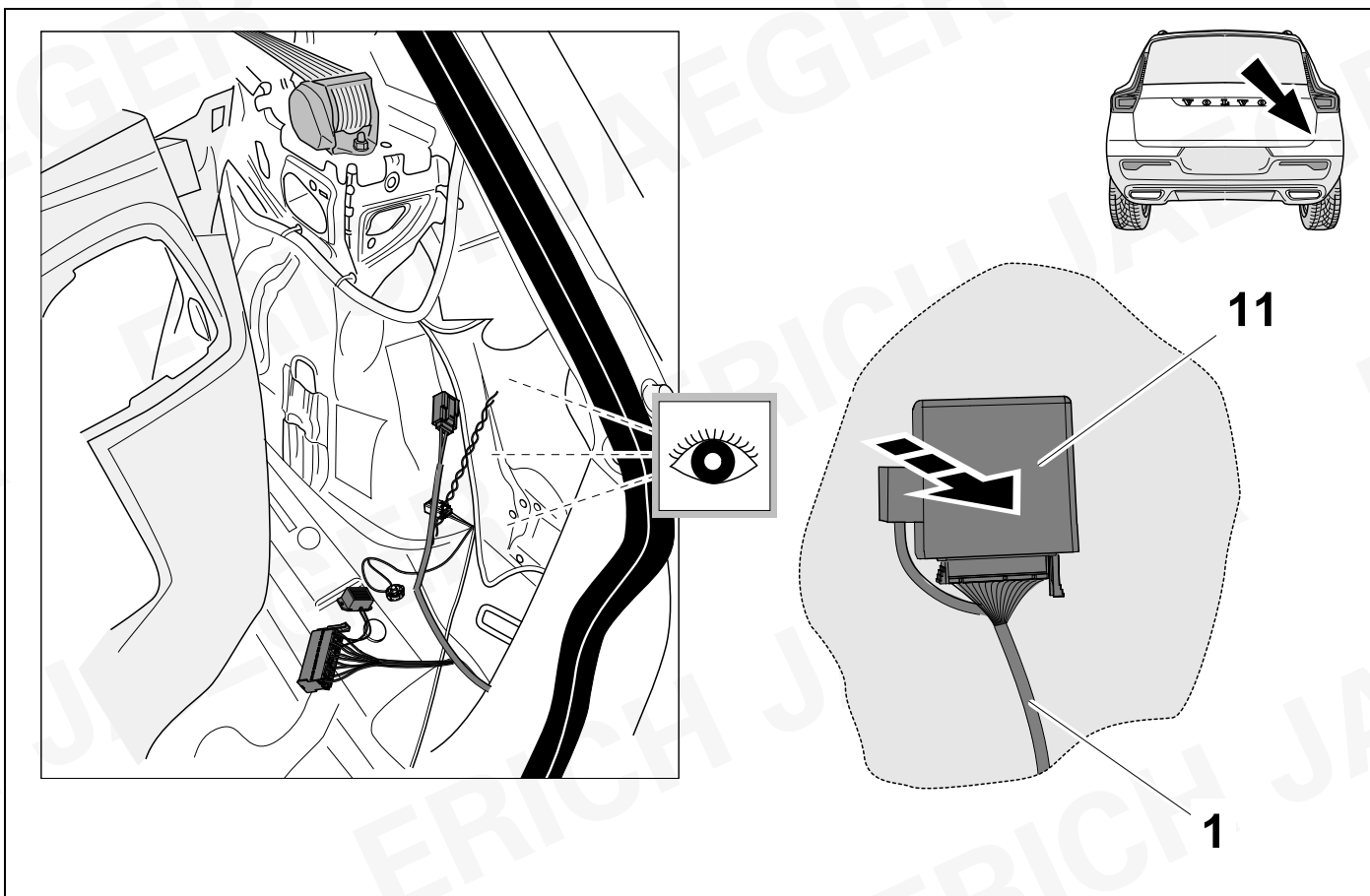

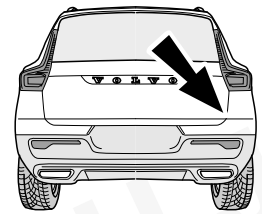
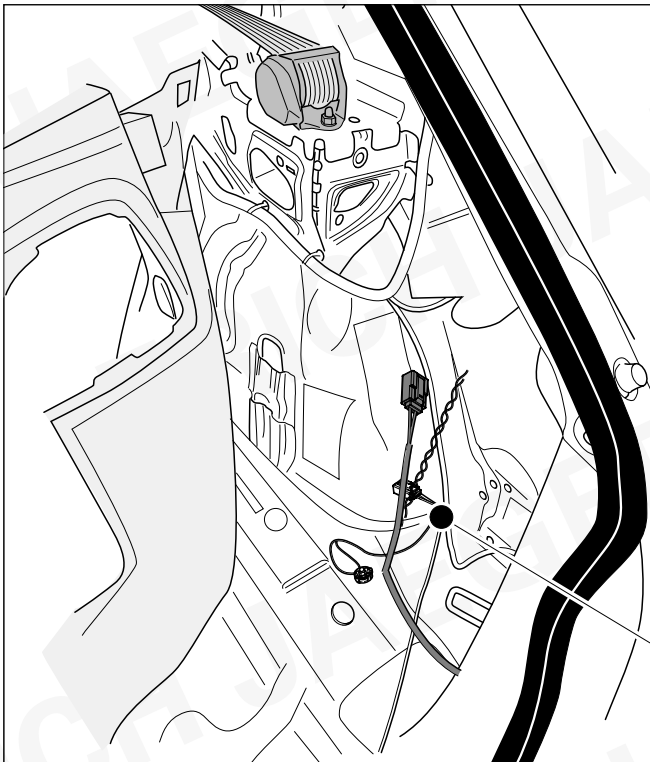

CAN

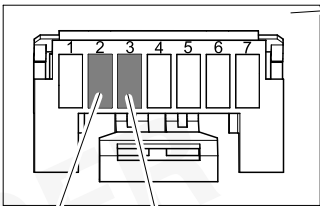
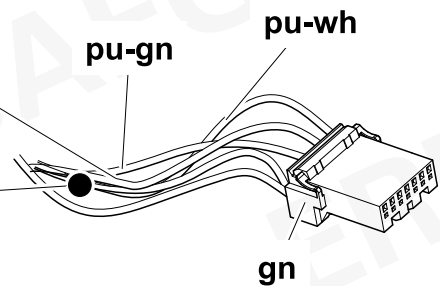

pu-wh pu-gn

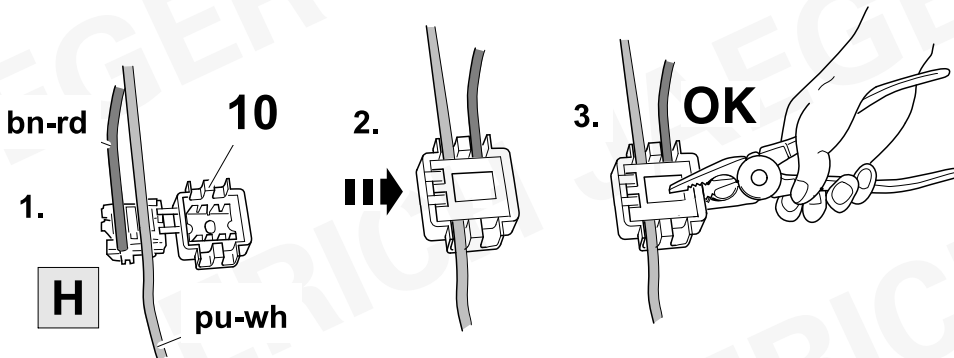
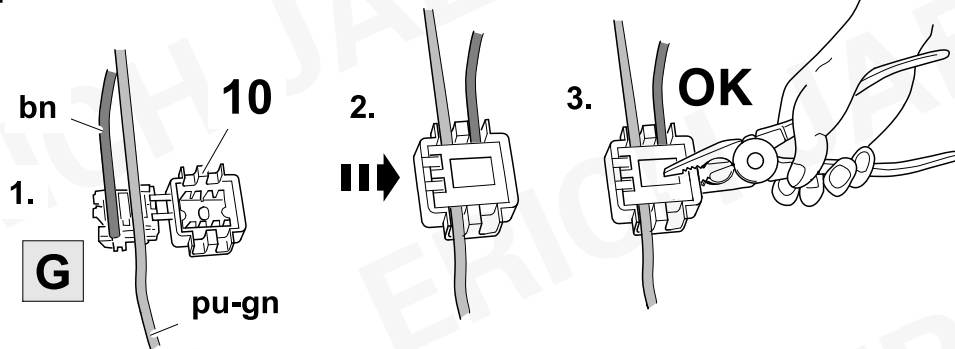

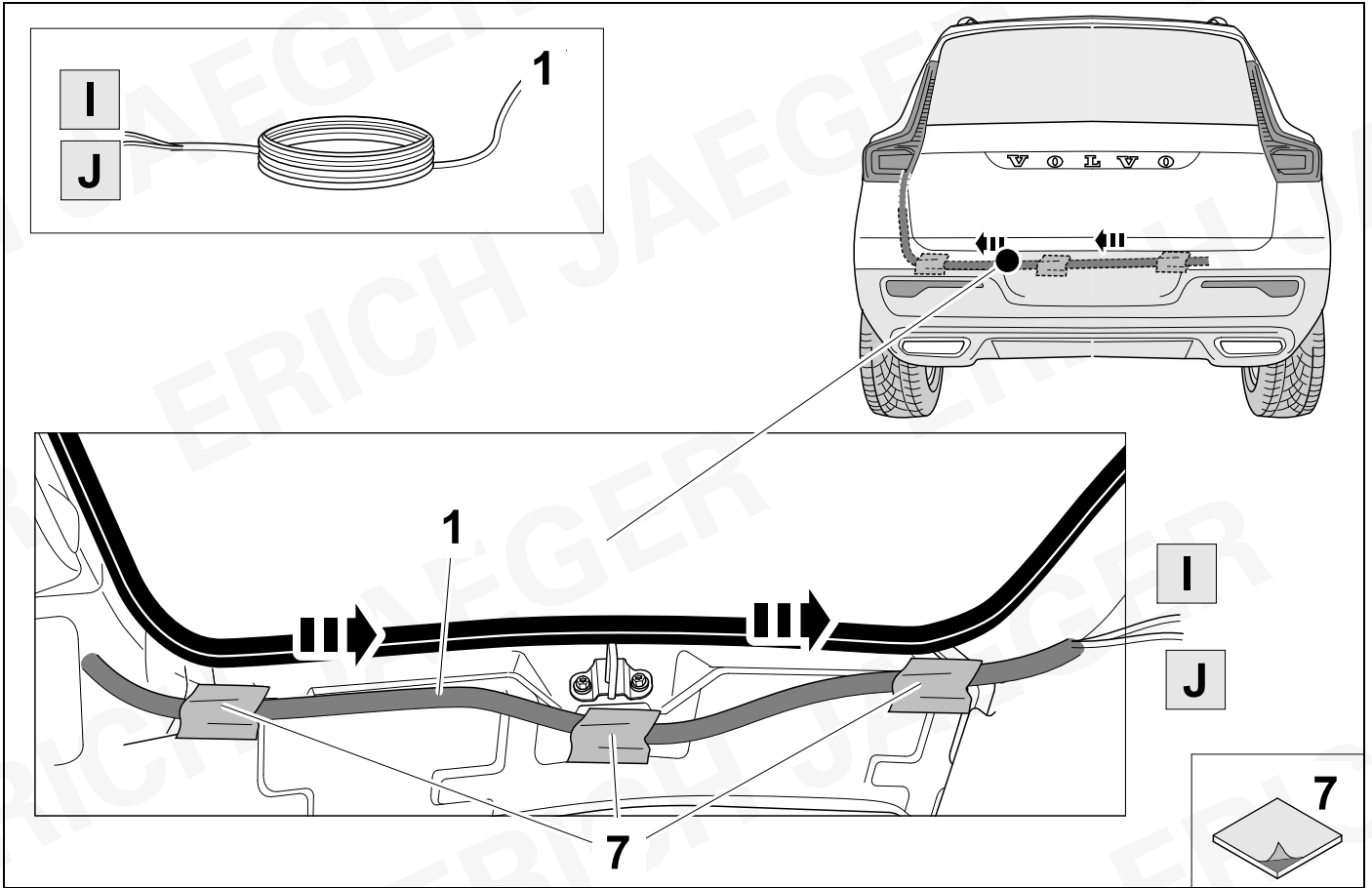

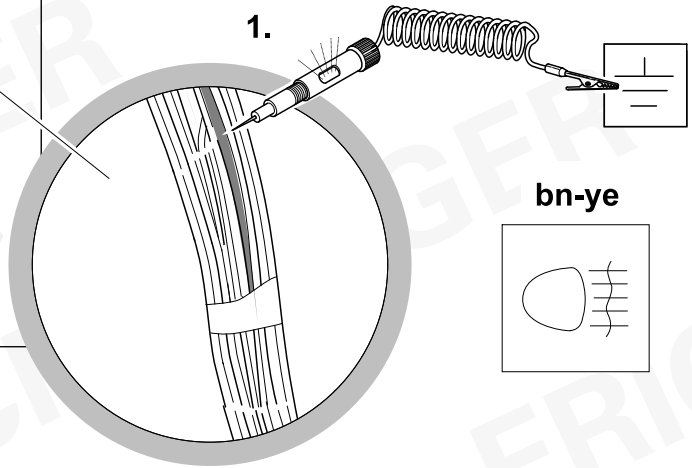
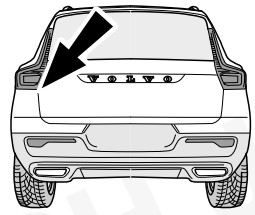
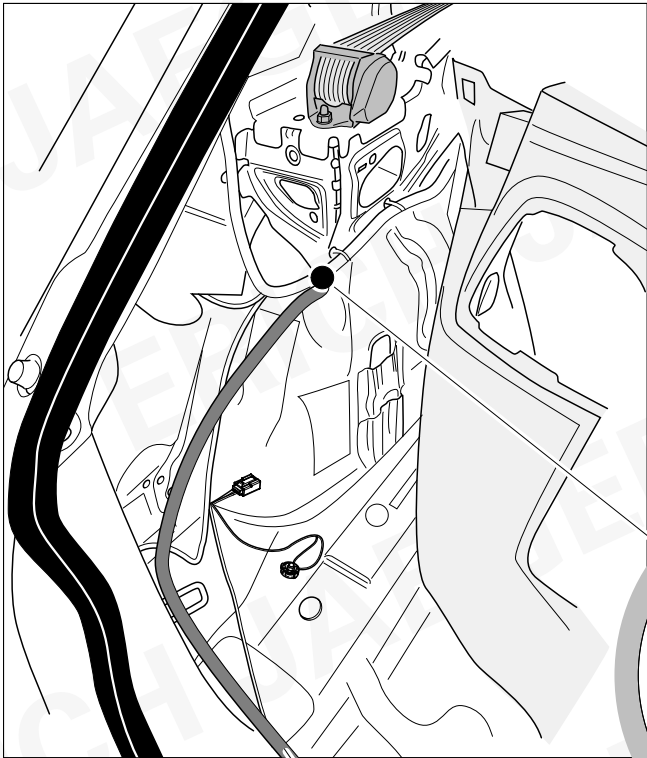

1

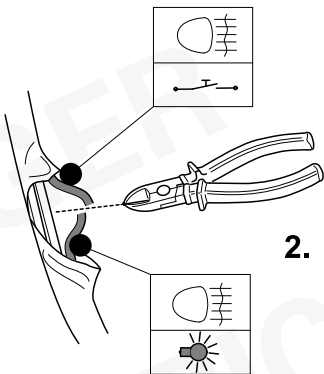

2.

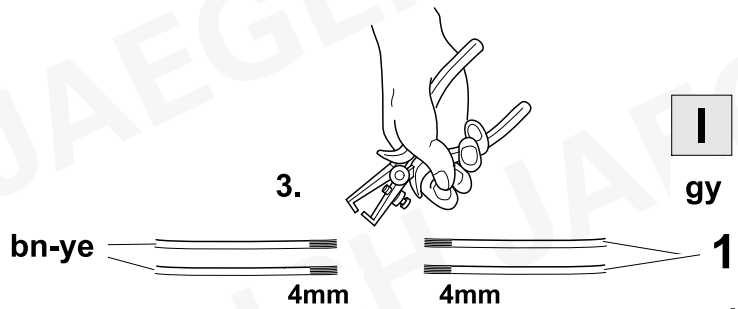

3.

I
gy

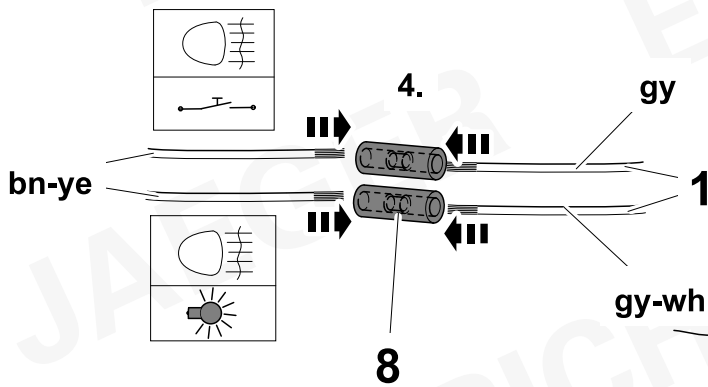

4.

gy

gy-wh

8

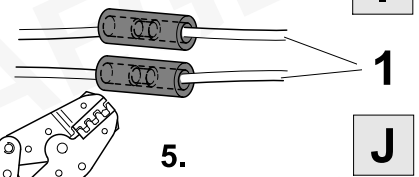

5.

J

I

J

17



9

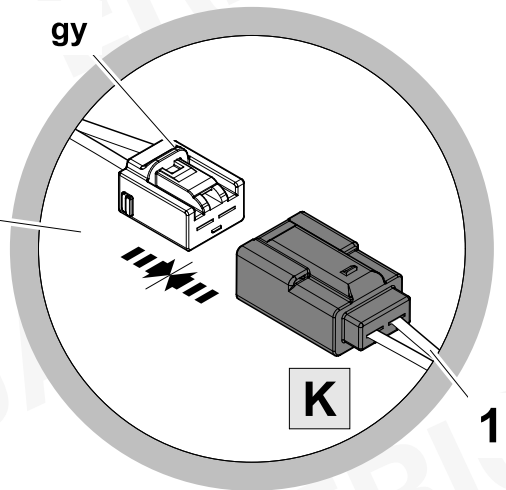
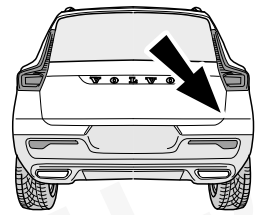
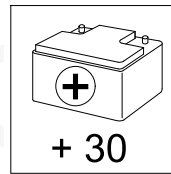

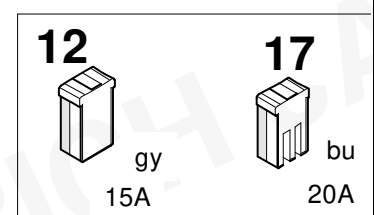
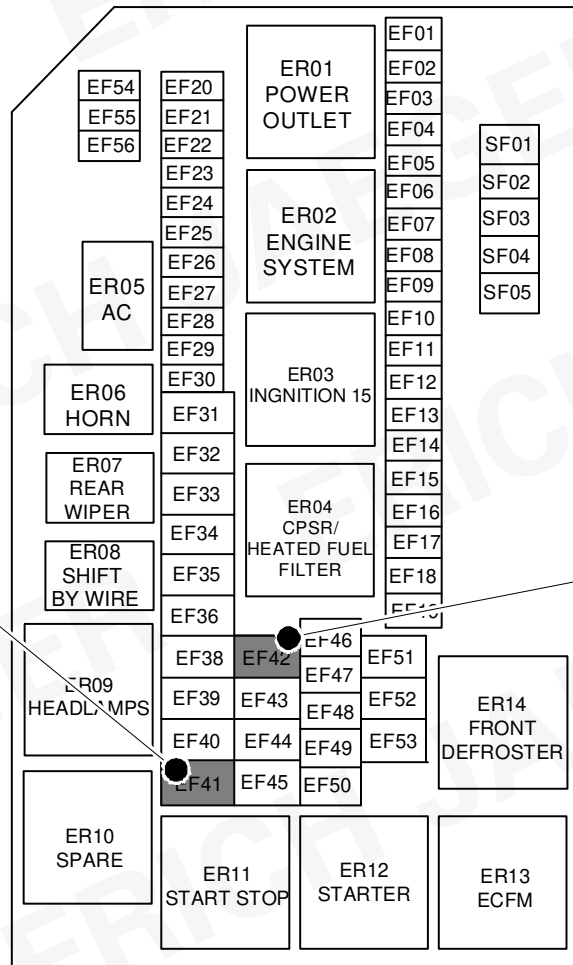
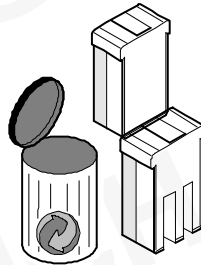
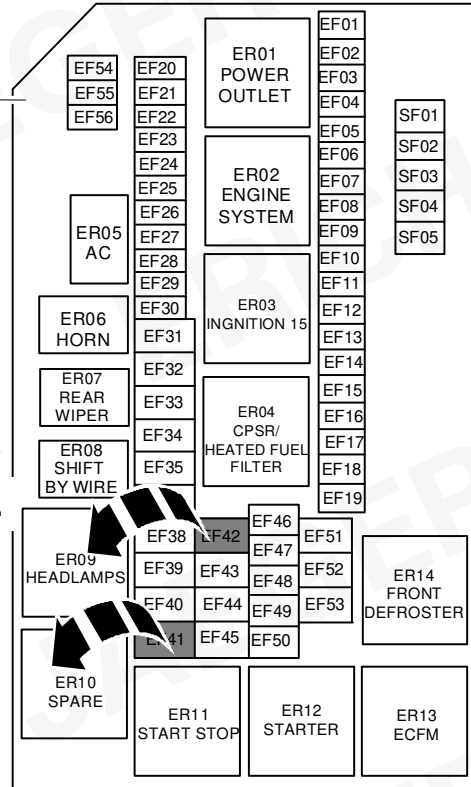
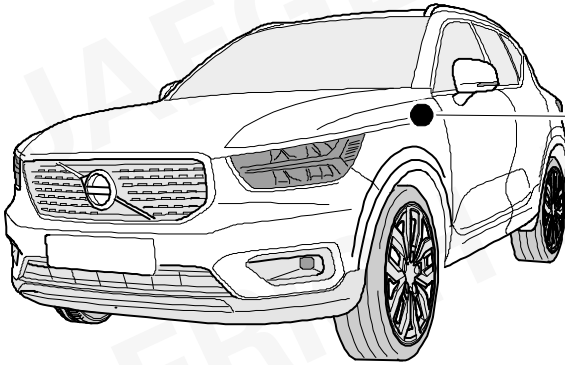

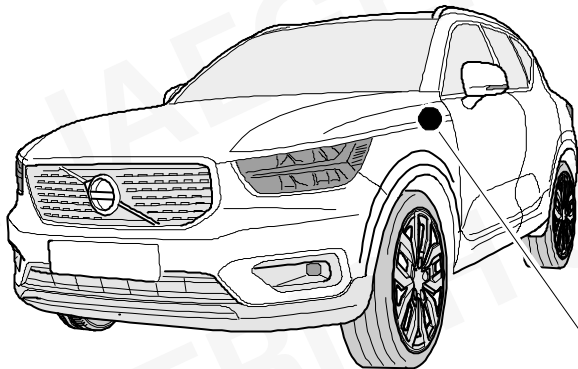

EF42

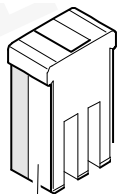

3.
20A bu
Slotted

EF41

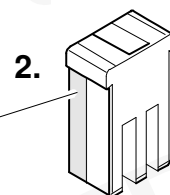

2.
15A gy

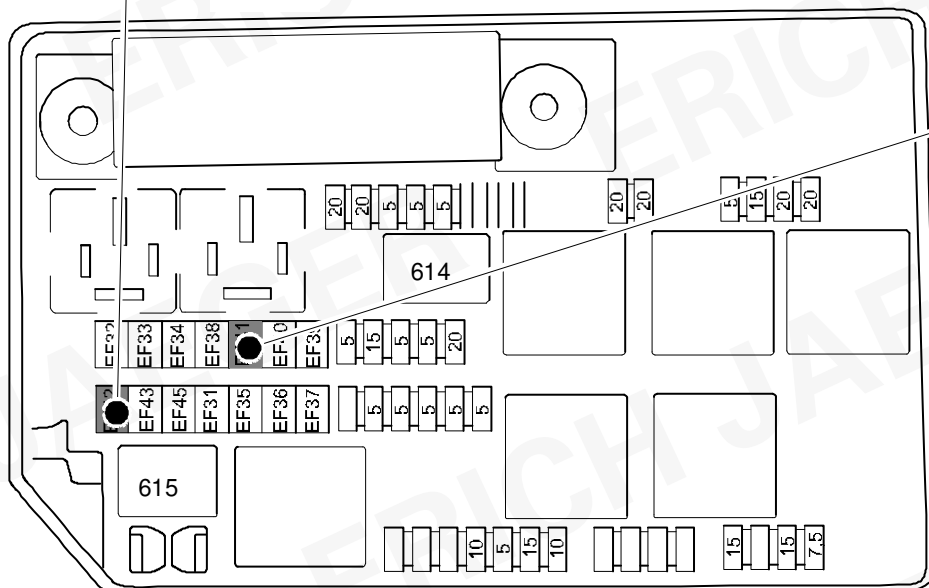

12





15A gy

17



20A bu

20

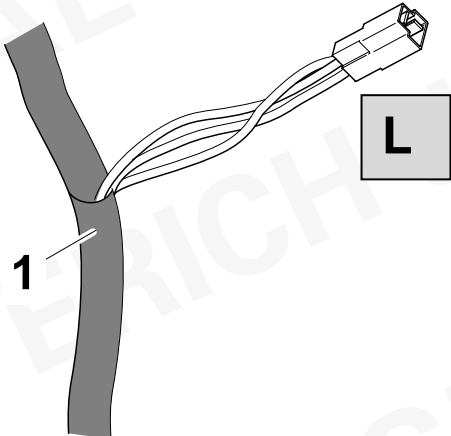
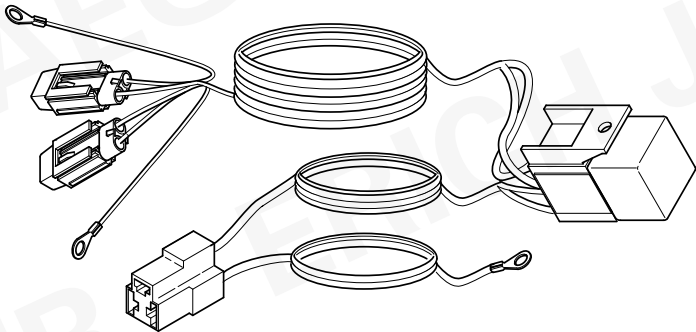
		ERICH JAEGER Artikelnummer: ERICH JAEGER part number:	721074
			

21

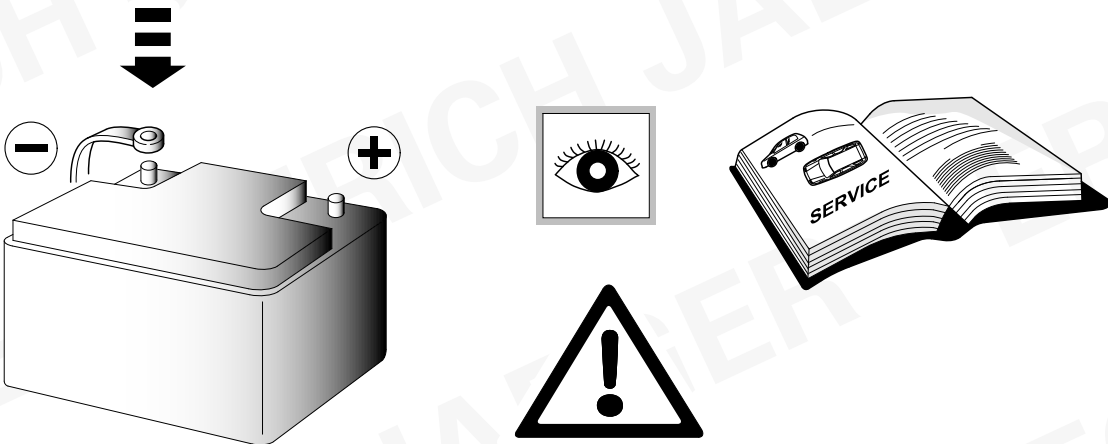

22 CHECK

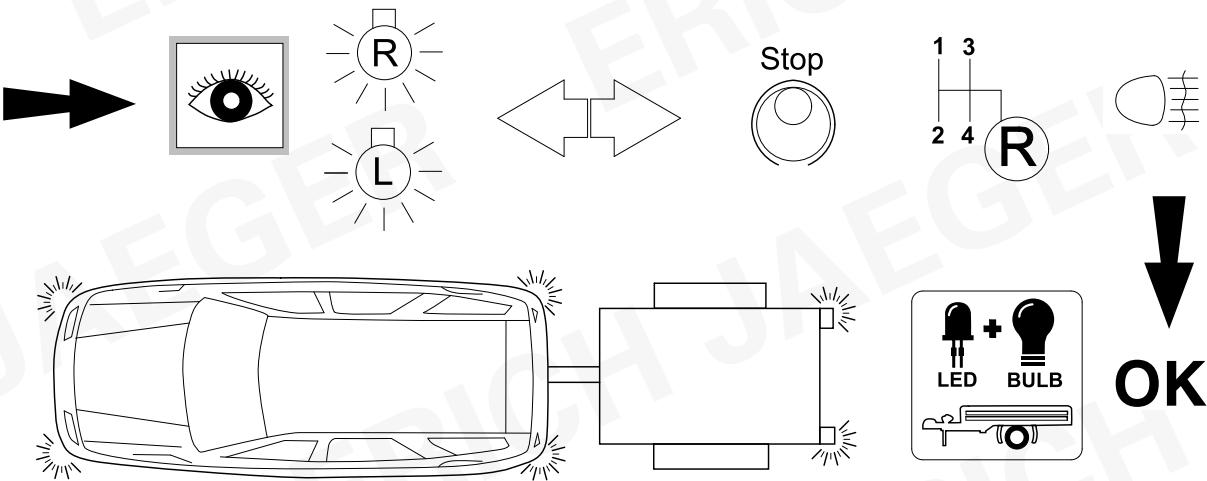

23 CHECK

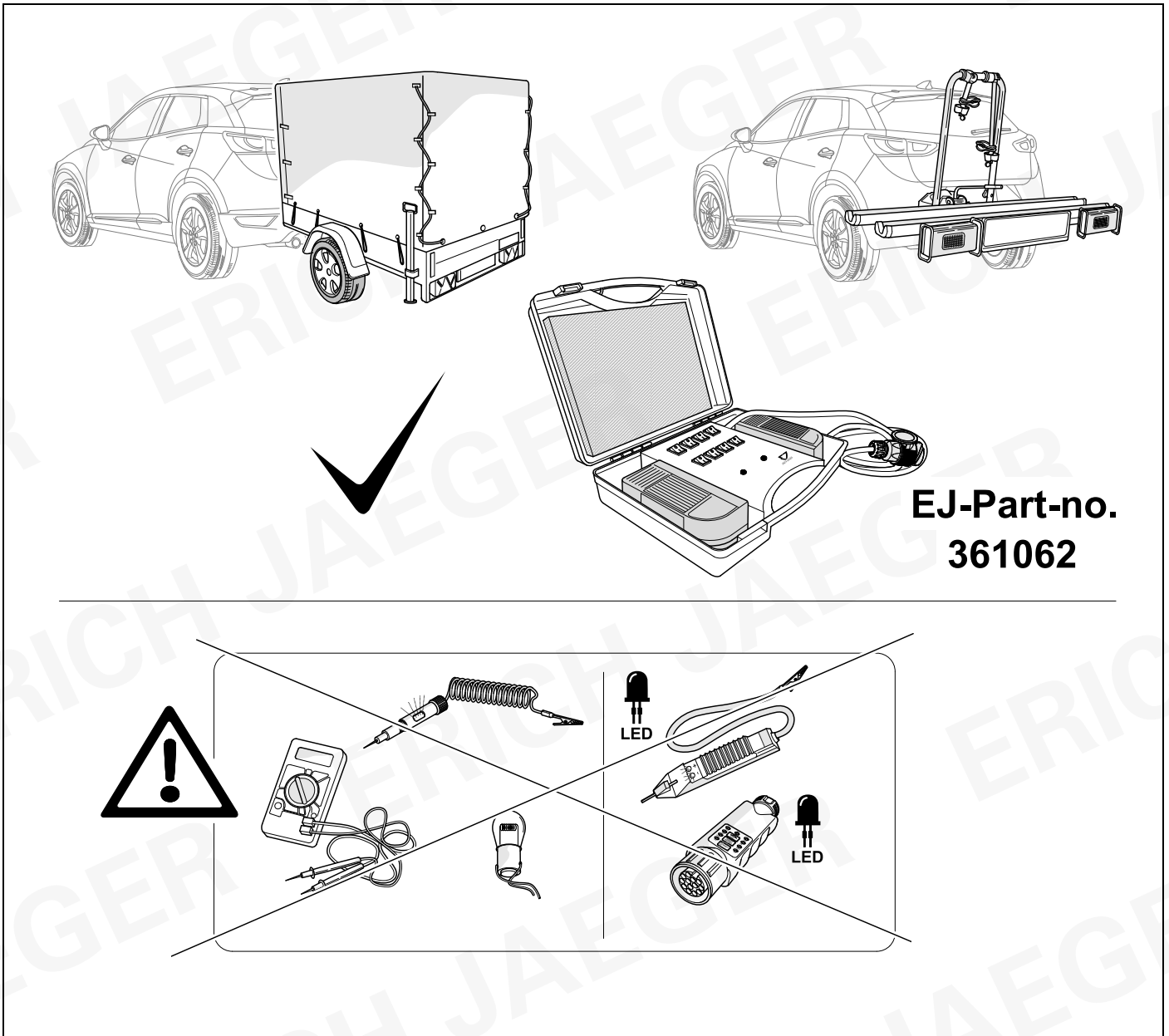

24 CHECK

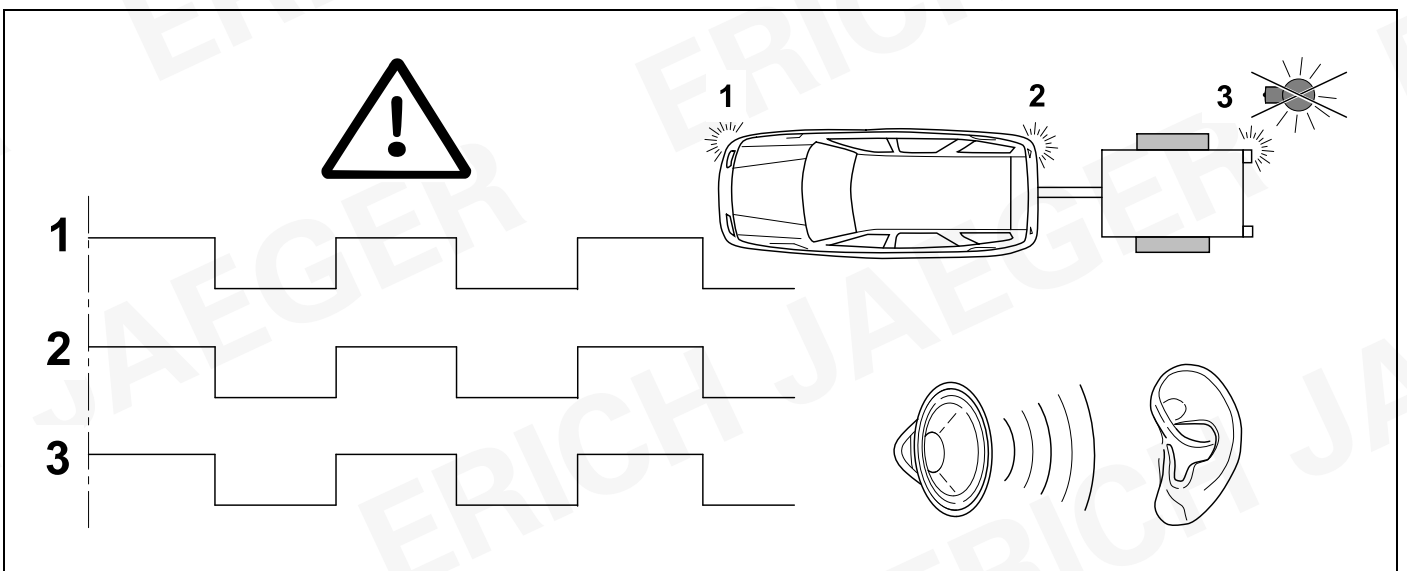

25 INFORMATION



19 + 20

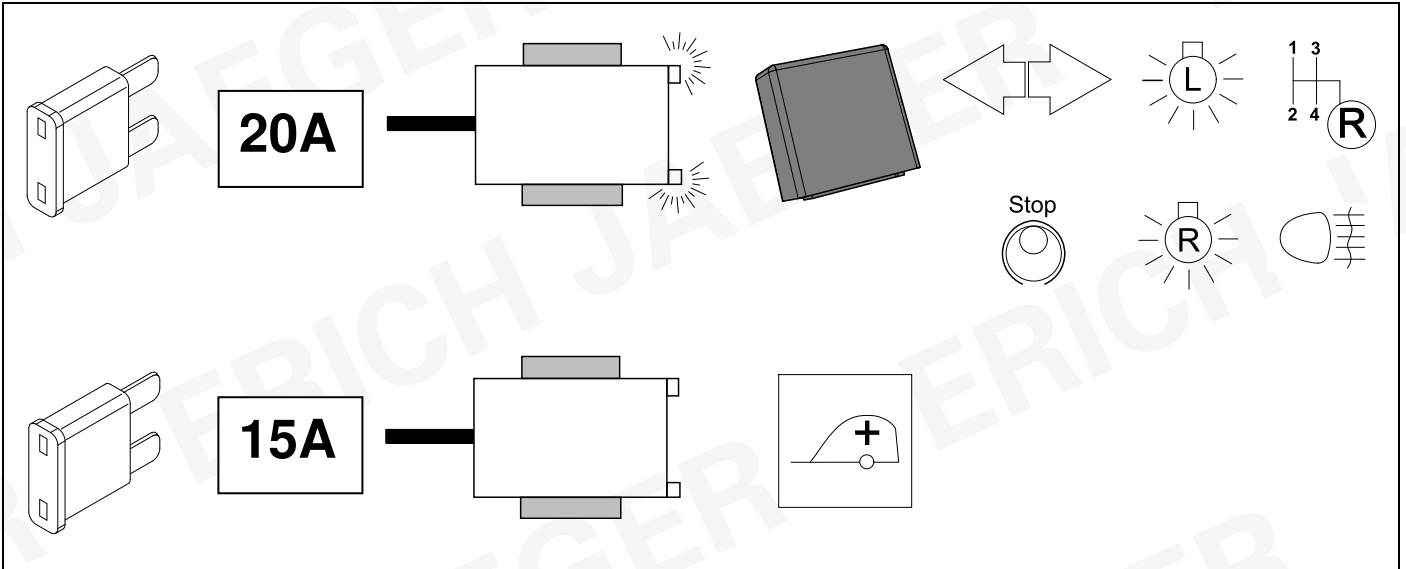

26 INFORMATION

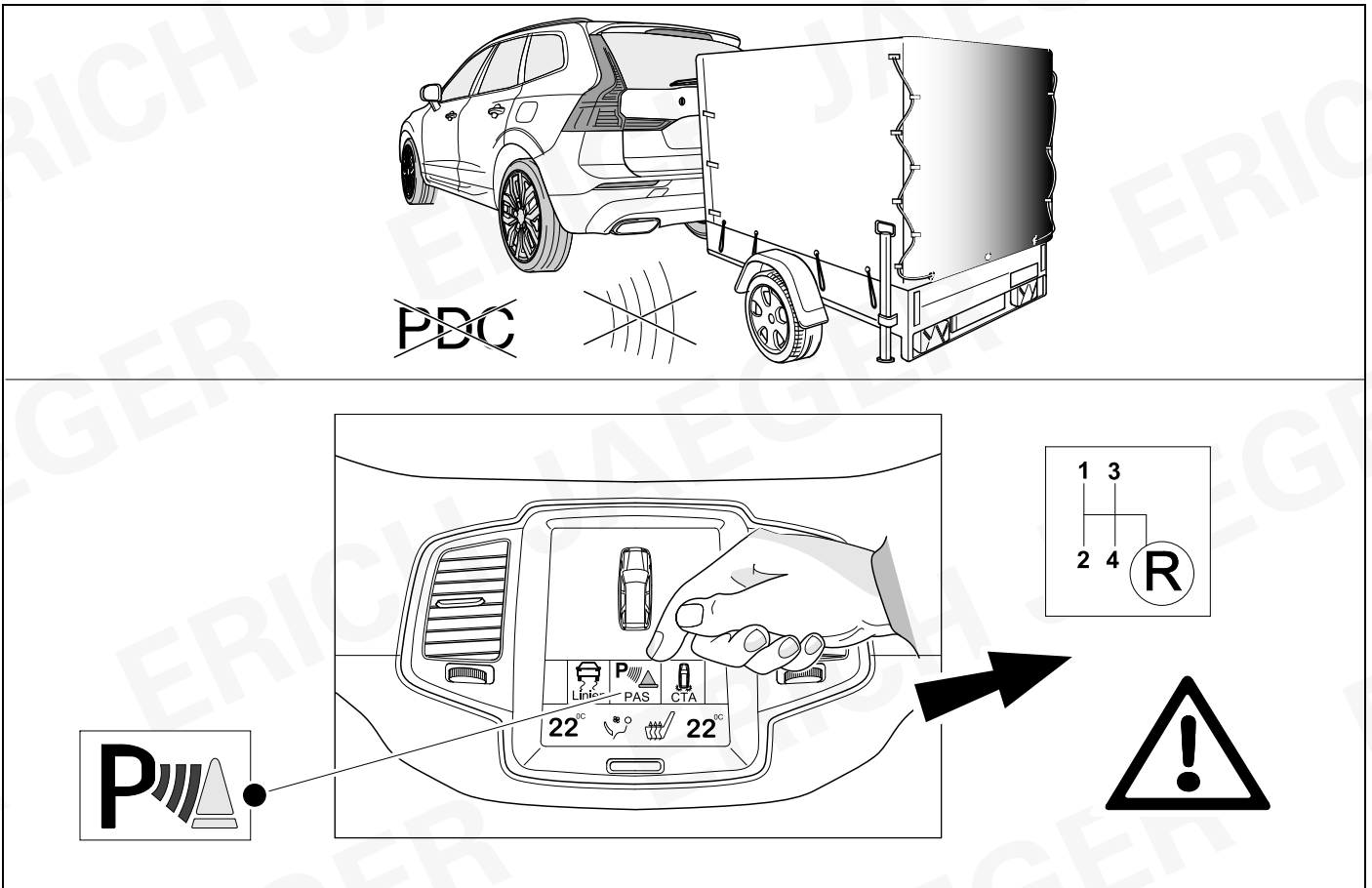

27 INFORMATION

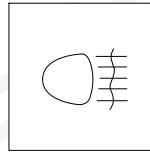

- D** Wenn die Nebelschlussleuchte am Fahrzeug eingeschaltet ist, darf der Anhänger nicht an -oder abgekuppelt werden!
- GB** If the rear fog lamp is switched on at the car, it is not allowed to couple -or decouple the trailer!

28 INFORMATION

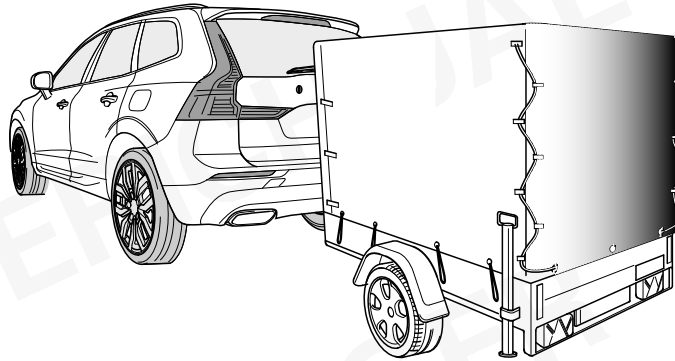

E-kit does not support assistance systems like:

- City safety
- Park Pilot
- Advanced stability control systems

29

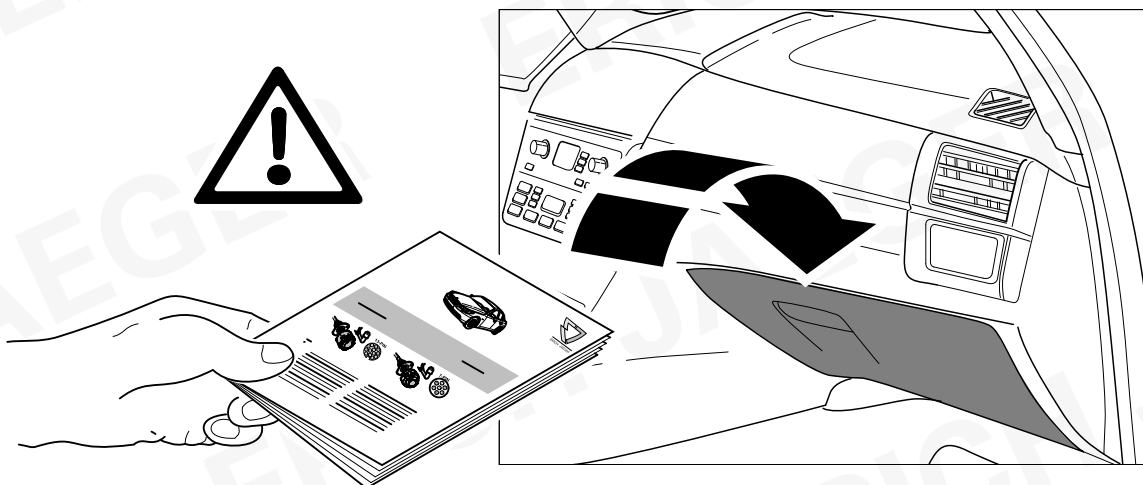

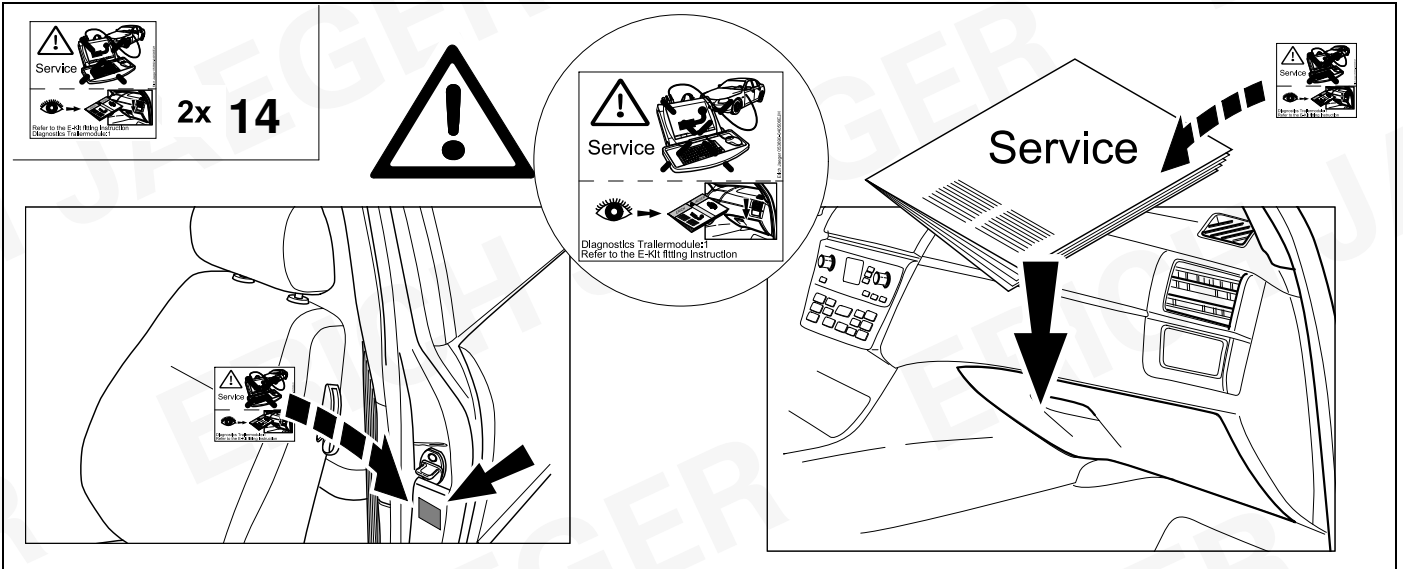

Status LED für Eigendiagnose

Status LED for self-diagnosis

Operation support

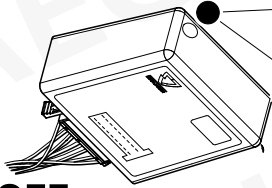
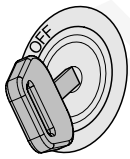

No CAN-Data =



Standby / Sleepmode

Ignition OFF

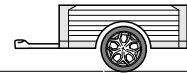
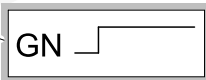
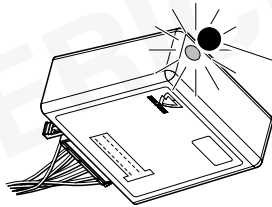

Ignition ON

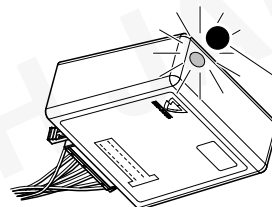
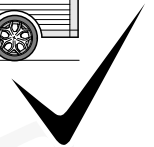

Ignition ON



Failure support

CAN-Data Wire



1x max. 5 min.

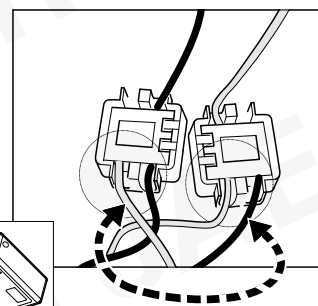
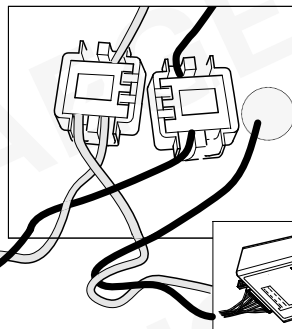
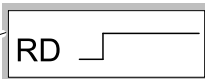
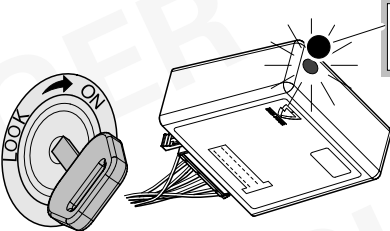

Ignition ON

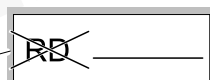
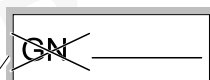
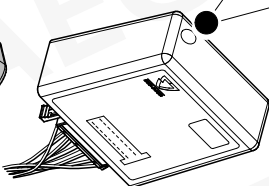
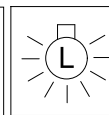
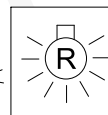

PIN 17 oder / or



PIN 1

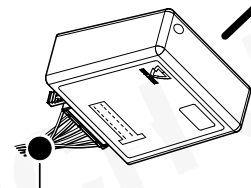
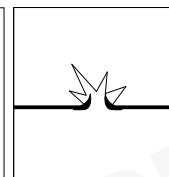
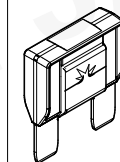
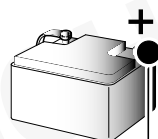

Ignition ON



D	Änderungen bezüglich Konstruktion, Ausstattung Farbe sowie Irrtum vorbehalten. Angaben und Abbildungen unverbindlich	PL	Zastrzega się prawo do zmian dot. konstrukcji, wykończenia, kolorystyki oraz pomylek. Dane i ilustracje niewiążące.
GB	Subject to change in terms of construction, equipment and colour, and may contain errors. The information and illustrations are non-binding.	TR	Tasarım, donanım ve renk bakımından değişiklik yapma hakkı ve hata ve eksiklik mahfuzdur. Veriler ve resimler bağlayıcı değildir.
F	Sous réserve de modifications de la construction, de l'équipement, de la couleur et sous réserve d'erreurs. Les indications et les illustrations sont sans engagement.	H	A szerkezet, a kivitel és a szín változtatása, valamint a változások joga fenntartva. Az adatok és az ábrák nem kötelező érvényűek.
NL	Wijzigingen met betrekking tot constructie, uitvoering en kleur evenals vergissingen voorbehouden. Gegevens en afbeeldingen niet bindend.	HR	Pravo promjena u svezi konstrukcije, opreme, boje kao i zabune oridžavamo. Podaci i ilustracije su neobavezne.
DK	Ændringer med hensyn til konstruktion, udstyr, farver samt fejl forbeholdes. Oplysninger og illustrationer er uforpligtende.	BUL	Запазени права по отношение на конструкцията, обзавеждането, цвета и грешки. Данните и изображенията не са обвързващи.
N	Ændringer angående konstruksjon, utstyr, farge og feiltagelse forbeholdes. Oplysninger og illustrasjoner uforbindtlig.	RO	Ne rezervăm dreptul unor modificări ale construcției, dotării, culorii și dreptul la erori Datele indicate și imaginile sunt orientative.
S	Med reservation för ändringar vad det gäller konstruktion, utrustning, färg samt för misstag. Uppgifterna och bilderna är inte bindande.	RU	Права на внесение изменений относительно конструкции, оснащения, окраски, а также на ошибки сохраняются. Данные и иллюстрации имеют примерный характер.
FIN	Pidätämme oikeuden rakennetta, varustusta, väriä koskeviin sekä erehdyksestä johtuviin muutoksiin. Tiedot ja kuvat eivät ole sitovia.	LT	Pasiliekaama konstrukcijos, įrangos bei reikmenų, spalvos pakeitimų ir klaidų teisė. Duomenys ir iliustracijos neįpareigojantys.
I	Con riserva di modifichie relative a progettazione, dotazione, colore ed errori. Le indicazioni e figure sono fornite senza impegno.	LV	Tiek paturētas tiesības uz konstrukcijas, iekārtu, krāsu izmaiņām, kā arī kļūdīšanās. Dati un attēli bez saistībām.
E	Reservadas las modificaciones respecto a diseño, equipamiento, color, así como error. Indicaciones y figuras sin compromiso.	EST	Konstruktsooni, varustuse ja vœrvi osas muudatused ning eksimine lubatud. Andmed ja joonised on mittedivuvad.
P	Reservamos o direito de alterações relativamente ao desenho, equipamento, cor, bem como de erro. Os dados e as gravuras não implicam compromisso da nossa parte.	SLO	Zadržana pravica do sprememb glede konstrukcije, opreme, barve ter pomote. Podatki in slike so neobvezne.
GR	Διατηρώνουμε κάθε επιφύλαξη ως προς αλλαγές σε σχέση με κατασκευή, εξοπλισμό, διαρρύθμιση, χρωματισμούς και λάθη παραδρομής.	SK	Zmeny, ktoré sa týkajú konštrukcie, vybavenia, farby, ako aj omyly sú vyhradené. Údaje a zobrazenia sú nezáväzné.
CZ	Změny, týkající se konstrukce, vybavení, barvy, jakož i omyly jsou vyhrazeny. Údaje a vyobrazení jsou nezávazné.		

ERICH JAEGER Artikelnummer:
ERICH JAEGER part number:

311069

