

TECHNICAL DATA SHEET

Type No.: AGM L5
Created : 05.02.2022
Modified : 05.02.2022

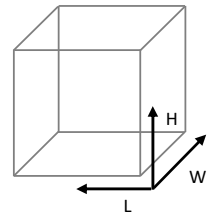
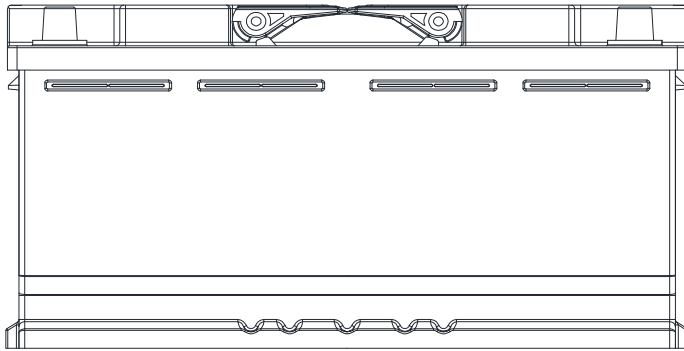
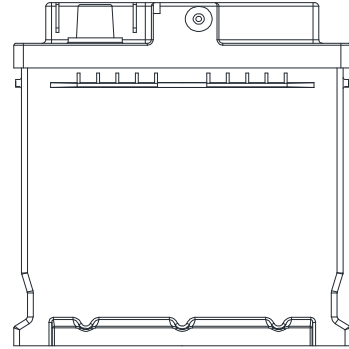
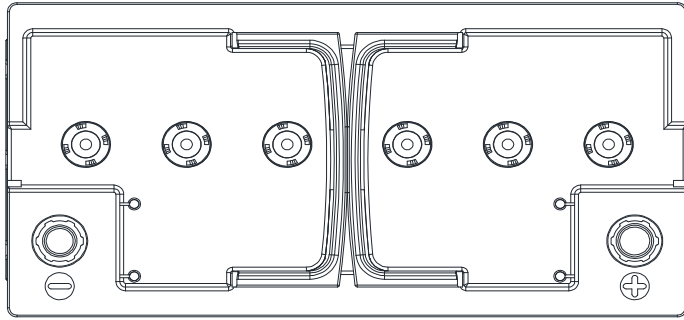

PERFORMANCE		CONTAINER	
VOLTAGE(V):	12 V	Group:	L5 Black
C20(Ah):	95 Ah	Hold Down:	B13
RC(min):	180 min	Please refer to the catalog or our website for the details of hold down types of the battery container.	
CCA(A):	850 EN	COVER	
Vibration:	V3	Type:	6-valved cap Black
Endurance:	E4	Polarity:	L
Water consumption:	W5	Terminals:	Standard
Technology:	VRLA	Filter:	2 Filters both sides
Grid alloy:	Ca/Ca	HANDLES	
WEIGHT AND STD. DIMENSION		Handles:	2 handles
Battery weight(kg):	26,10	REMARK	
Volume acid(l):	4,72		
Length(mm):	352		
Width(mm):	174		
Height(mm):	190		
Total Height(mm):	190		