

TECHNICAL DATA SHEET

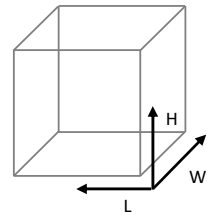
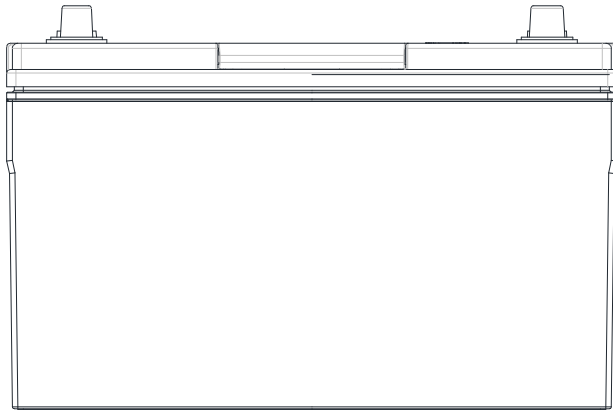
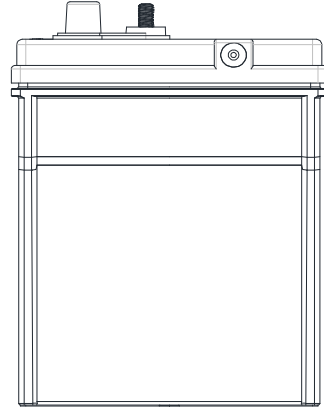
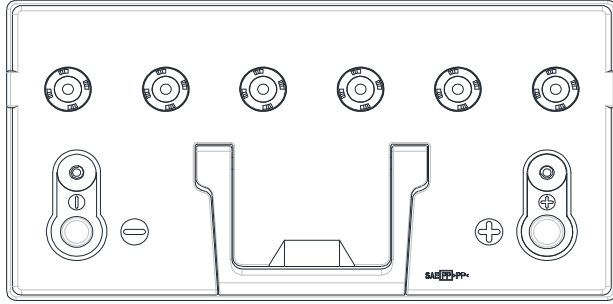

PERFORMANCE		CONTAINER	
VOLTAGE(V):	12 V	Group:	31 Black
C20(Ah):	100 Ah	Hold Down:	B0
RC(min):	200 min	Please refer to the catalog or our website for the details of hold down types of the battery container.	
CCA(A):	925 EN	COVER	
Vibration:	V3	Type:	6-valved cap Black
Endurance:	E4	Polarity:	R
Water consumption:	W5	Terminals:	MARINE TWIN*
Technology:	VRLA	Filter:	2 Filters both sides
Grid alloy:	Ca/Ca	HANDLES	
WEIGHT AND STD. DIMENSION		Handles:	1 Handle
Battery weight(kg):	27,20	REMARK	
Volume acid(l):	4,87		
Length(mm):	332		
Width(mm):	172		
Height(mm):	231		
Total Height(mm):	231		