



PIERBURG



# EXHAUST GAS RECIRCULATION

PROVEN PIERBURG TECHNOLOGY  
FOR CONTROLLING EMISSIONS

TAKING RESPONSIBILITY IN A CHANGING WORLD



RHEINMETALL



# EXHAUST GAS RECIRCULATION – AN INDISPENSABLE WAY OF CONTROLLING EMISSIONS

Exhaust gas recirculation (EGR) has not only proven to be an effective way of controlling emissions in petrol engines – practically all modern diesel engines must also be fitted with the technology to comply with increasingly stringent exhaust gas regulations. Compliance with even lower limit values will only be possible by using a cooled exhaust gas recirculation system.

Pierburg has made a substantial contribution to the current state of the art and, as a highly experienced system supplier, is able to offer a compact and efficient system for controlling emissions – for passenger cars and utility vehicles.

There's a reason why Pierburg is represented as the OEM in a large number of modern vehicles with EGR valves and EGR coolers. The corrosion and temperature-resistant materials used in the Pierburg products guarantee lasting function under the harshest conditions, e.g. aggressive exhaust gas condensate, temperatures up to 700°C and pressures up to 3 bar.

## COMPONENTS IN EXHAUST GAS RECIRCULATION

In the case of exhaust gas recirculation, a certain amount of exhaust gas is mixed with the intake air. This means that less oxygen reaches the cylinder. This leads to a lower combustion temperature. As a result, the amount of nitrogen oxides in the exhaust gas can be reduced by up to 50%. In petrol engines, this can also reduce carbon dioxide emissions and fuel consumption.

There are various positions for exhaust gas removal:

### INTERNAL EGR

- Valve overlapping means that some exhaust gas remains in the combustion chamber or is sucked back into the cylinder from the outlet duct.
- The timing of the intake and exhaust valves is changed by means of adjustable cams.

### EXTERNAL EGR

- Exhaust gas is removed outside the cylinder head on the exhaust-gas side and is fed back via lines or ducts to the fresh air side through an external valve.
- This provides the opportunity for additional exhaust gas cooling by an optional cooler with / without bypass flap.

There are two types of external EGR:

#### HIGH-PRESSURE EGR

The exhaust gas is

- removed immediately behind the cylinders in front of the turbocharger turbine and
- fed to the fresh air side behind the throttle valve.

#### LOW-PRESSURE EGR

The exhaust gas is

- removed downstream of the turbocharger turbine or only downstream of the exhaust gas treatment systems and
- supplied to the turbocharger compressor.

An exhaust gas flap provides the necessary exhaust gas back pressure if the pressure difference is not sufficient for the required EGR mass flow rates. The exhaust gas is also cooled by a special low-pressure EGR cooler.

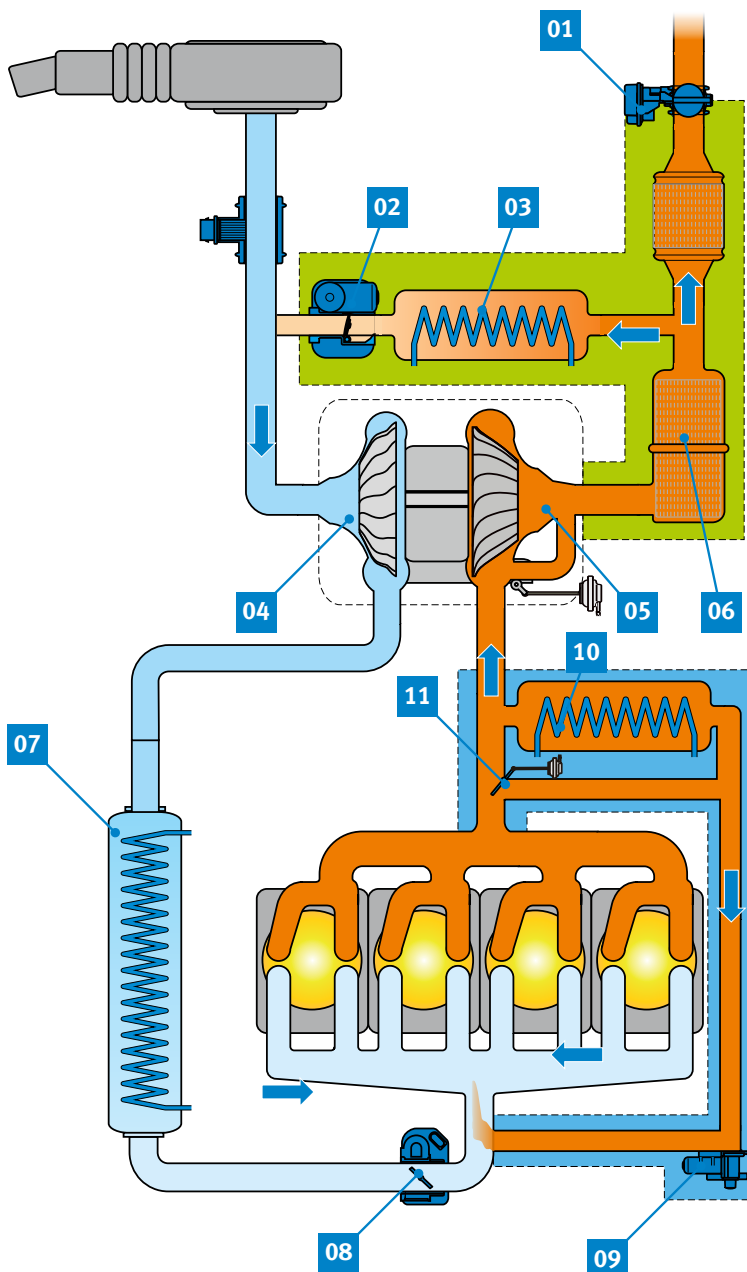

Exhaust gas recirculation (schematic)

- 01 Exhaust gas flap
- 02 Low-pressure EGR valve
- 03 Low-pressure EGR cooler
- 04 Turbocharger (compressor)
- 05 Turbocharger (turbine)
- 06 Particulate filter
- 07 Charge air cooler
- 08 Throttle valve / regulating throttle
- 09 High-pressure EGR valve
- 10 High-pressure EGR cooler
- 11 Bypass flap

■ High-pressure range

■ Low-pressure range

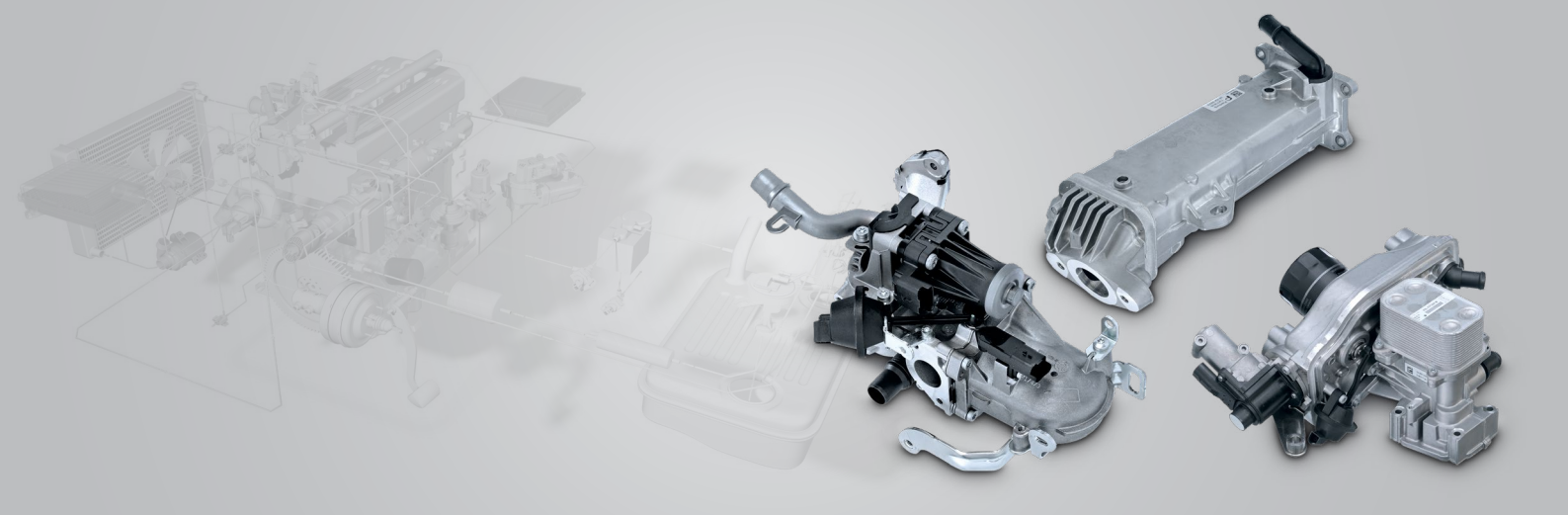

# COOLED EXHAUST GAS RECIRCULATION FOR EVEN LOWER POLLUTANT EMISSIONS

As a specialist with many years of experience in emission control, Pierburg is an expert OE supplier of systems for cooled exhaust gas recirculation. Motorservice is now bringing this technology to the aftermarket.

Ever more stringent emission regulations require a constant improvement in emission control methods. For diesel engines, this particularly applies to a further reduction in nitrogen oxides (NOx). This is why cooled exhaust gas recirculation is used here: It lowers the combustion chamber temperatures, thus reducing the formation of nitrogen oxides.

Calling on its many years of experience in the development and manufacture of EGR systems, Pierburg has designed a range of EGR cooler modules that permit precise cooling of exhaust gases. This is sophisticated technology in the smallest of spaces.

## What is special about Pierburg EGR coolers?

- The lamella geometry developed by Pierburg reduces the danger of sooting in the cooler.
- Special surface coating in the EGR cooler to prevent soot build-up
- Greater integration: Compact EGR cooler modules made of aluminium with integrated EGR valve, bypass flap and other attachments such as oil coolers and oil filters

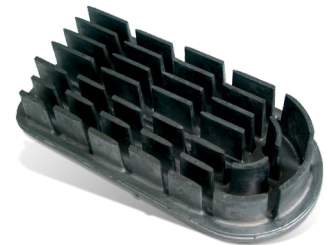

Pierburg lamella geometry



## BYPASS FLAPS IN EGR COOLER

Many of today's EGR coolers feature an electrical or pneumatic bypass flap. This allows the exhaust gases to be directed past the EGR cooler in the warm-up phase, to quickly bring the engine and catalytic converter up to operating temperature. This also reduces the amount of noise – what is known as “diesel knock” – as well as the level of raw hydrocarbon emissions in the warm-up phase. Bypassing is also possible if high exhaust gas temperatures are required, for example in the recovery of diesel particulate filters.

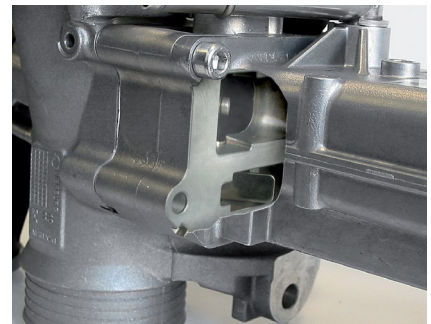

Bypass flap in the EGR cooler (cut away view)

### Why is cooled exhaust gas recirculation necessary?

Cooled exhaust gas reduces the peak combustion temperature. This significantly reduces the amount of nitrogen oxides. Additionally, cooled gases are denser than warmer ones. This means: at the same boost pressure, a larger volume of gas fits into one cylinder filling. This produces a “leaner” combustion which also improves fuel consumption and particulate emissions. EGR coolers are used for targeted cooling of the recirculated exhaust gases.

### COOLED EXHAUST GAS RECIRCULATION – ADVANTAGES AT A GLANCE

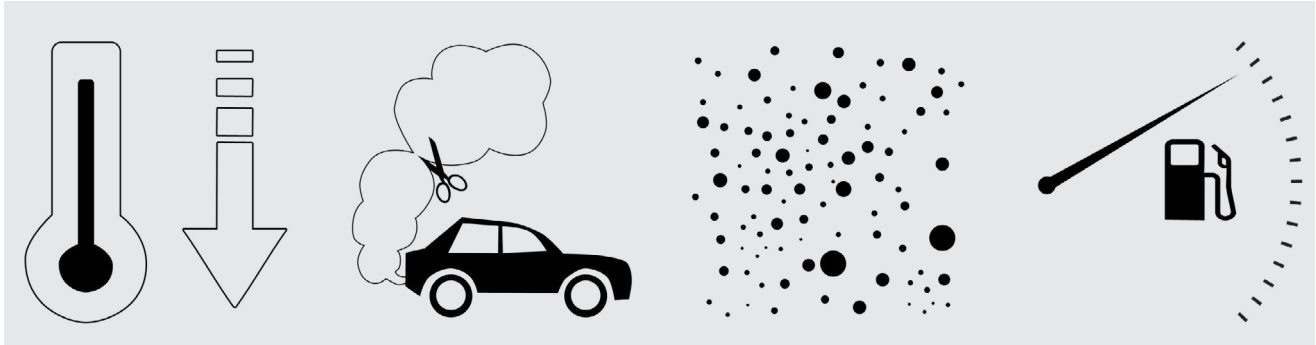

Reduced peak combustion temperature

Up to 50% reduction in nitrogen oxides

Reduced particulate emissions

Lower fuel consumption

### EGR COOLER

The EGR cooler is a small but crucial component in vehicles. An EGR cooler is used for the targeted cooling of the recirculated exhaust gases and, in addition to the EGR valve, is one of the main elements of the exhaust gas recirculation system. It is integrated into the engine’s coolant circuit and uses the coolant to reduce the temperature of the exhaust gases. Pierburg EGR coolers are manufactured according to OE standards and quality management standards in the automotive sector. All main components meet the quality requirements for initial assembly products.



### EGR VALVES

A key component of exhaust gas recirculation is the EGR valve. It meters the quantity of exhaust gas that is fed back. EGR valves are available in many versions and models: electrically or pneumatically controlled for petrol or diesel applications or with connection to the coolant circuit. Electric EGR valves are predominantly used nowadays as they require neither a vacuum nor a solenoid valve for the actuation. Due to the higher return rates involved, EGR valves for diesel applications have relatively large opening cross-sections. The cross-sections for petrol engines are much smaller.



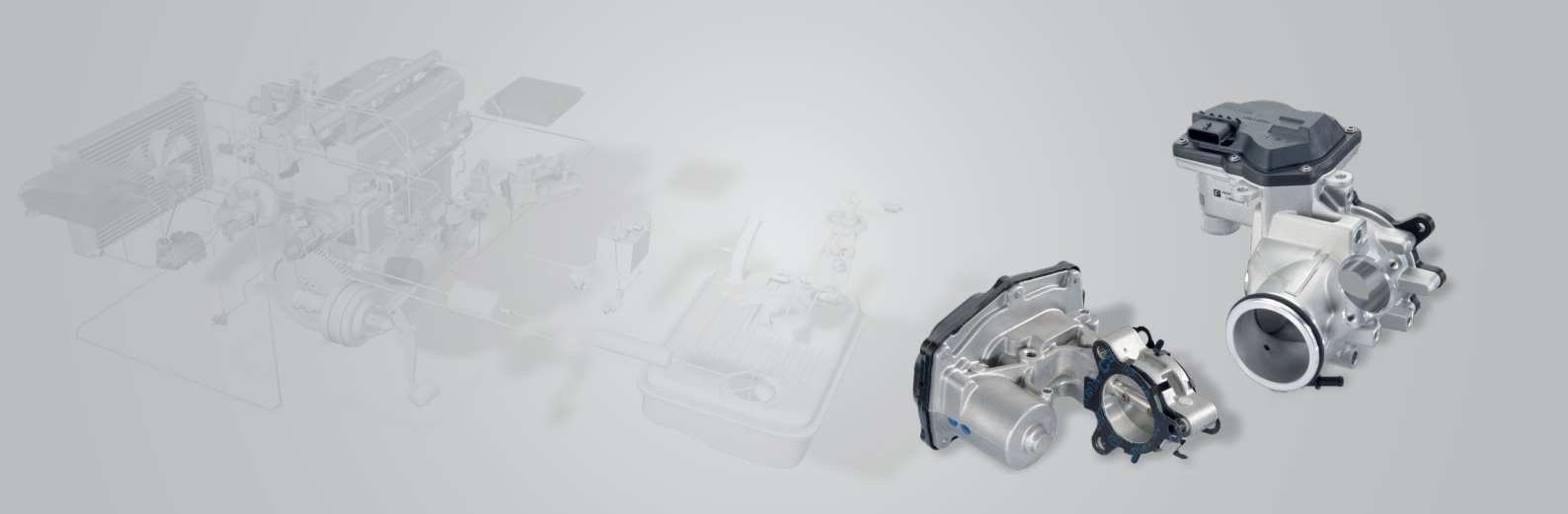

# HIGH-PRESSURE / LOW-PRESSURE EXHAUST GAS RECIRCULATION

## WHAT IS THE DIFFERENCE?

Raw emissions from engines are continually being reduced with technical measures. But as the emission limit values keep getting tighter and tighter, the technologies in non-engine measures need to keep improving as well.

Exhaust gas recirculation has proven to be a successful emission control method. In the case of conventional high-pressure EGR, exhaust gas is removed immediately after the cylinder and mixed with the intake air. A low-pressure EGR system is also required to achieve the limit values from Euro 6 / Tier 2. With this system, the exhaust gas is taken after the particulate filter on the low-pressure side, and added again before the turbocharger compressor. An exhaust gas flap provides the exhaust gas back pressure required for this.

**But what is the difference? The table below provides a brief overview.**

	High-pressure EGR	Low-pressure EGR
<b>Inlet pressure into the EGR section</b>	High (up to approx. 3.5 bar)	Low (up to approx. 1.3 bar)
<b>Inlet temperature into the EGR section</b>	Very high (up to approx. 950°C)	High (up to approx. 800°C)
<b>Pressure difference <math>\Delta p</math> over the EGR section</b>	High (up to approx. 1.5 bar)	Low (up to approx. 0.3 bar)
<b>Cyclical pressure fluctuations</b>	High	Low
<b>Exhaust gas composition</b>	Removal before exhaust gas after-treatment	Removal after exhaust gas after-treatment

## LOW-PRESSURE EGR

Low-pressure EGR represents the state of the art with regard to diesel engines.

The advantages of adding low-pressure EGR to high-pressure EGR include:

- Higher performance/efficiency of the turbine
- Larger EGR map
- More homogeneous mixing of exhaust gas with fresh air via the compressor
- Resulting in lower NOx and particulate emissions
- Improved EGR cooling (through EGR and charge air cooler)

The disadvantages compared to high-pressure EGR include:

- Longer paths and additional components
- Possible hazard due to soiling or damage to the turbocharger compressor, e.g. through droplet impact

The low-pressure EGR valves from Pierburg generally consist of a centrally positioned flap (“butterfly”) in an aluminium pressure die-cast housing. The integrated actuating drive usually consists of a DC electric motor and a two-stage spur gear. The low-pressure valves were designed using assembly groups from existing throttle valve and EGR valve product lines that have been in tried and tested series production for years.

The low-pressure EGR combi valve simultaneously assumes the tasks of the low-pressure EGR valve and an intake air throttle. Throttling causes a pressure gradient to the intake side. This causes the exhaust gas to flow in a controlled manner into the area in front of the compressor. As a combined component, the low-pressure combi valve is not only more cost-effective, but also offers the benefit of a lower weight.



Low-pressure EGR valve (butterfly)



Low-pressure EGR combi valve

### NOTE

Typical damage in the area of the low-pressure EGR includes:

- Leakages in the exhaust gas lines or the coolant line
- Leakages in or on the EGR cooler
- Low-pressure EGR valve leaks/does not open or close
- Electrical actuation of the servo motor defective

Pierburg products for exhaust gas recirculation – at a glance

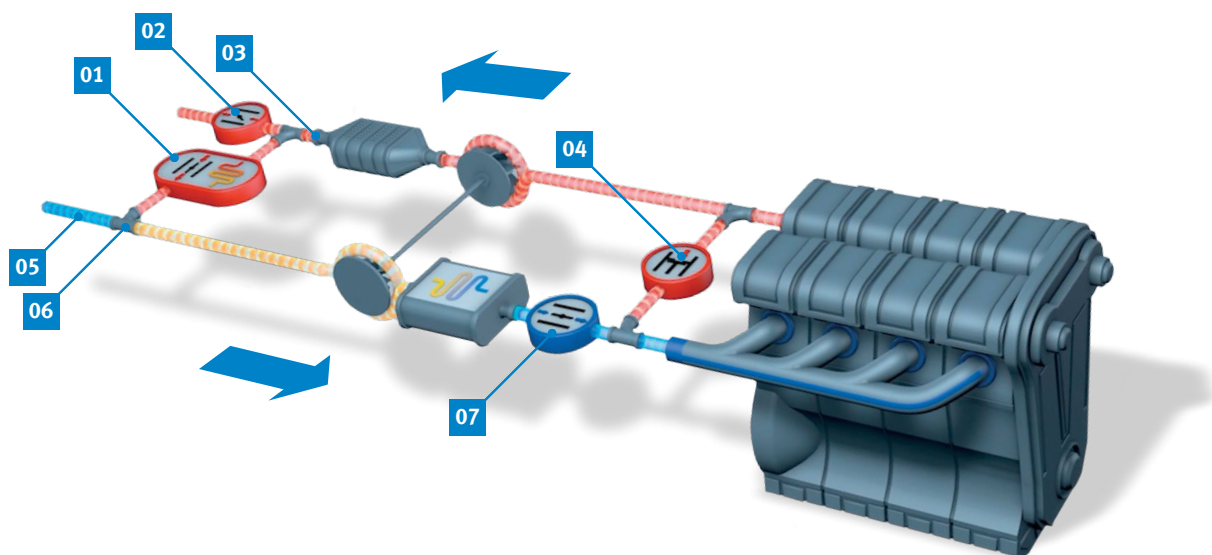

**01** EGR VALVES (LP)



**02** EXHAUST GAS FLAPS



**03** EXHAUST GAS SENSORS



**04** EGR VALVES AND  
EGR COOLERS (HP)



**05** AIR MASS SENSORS



**06** EGR COMBI VALVES (LP)



**07** THROTTLE VALVES /  
REGULATING THROTTLES





**We offer a comprehensive product portfolio covering a large number of engines.  
Here are some examples of our best-selling passenger cars in the aftermarket.**

Product	Item no.	Ref. no.	Manufacturer	Vehicle examples
EGR cooler	7.09730.02.0	03G 131 512 AA, 03G 131 512 AD, 03G 131 512 G	Audi, Seat, Škoda, Volkswagen	A3, Altea, Cordoba, Ibiza III / IV, Leon, Toledo III, Fabia II, Octavia II, Roomster, Superb II, Caddy III, EOS, Golf (Plus) V, Jetta III, Passat B6, Polo IV, Touran
	7.09730.04.0	03L 131 512 B, 03L 131 512 L	Audi, Seat, Škoda, Volkswagen	A3, TT, Altea, Leon, Toledo III, Octavia II, Superb II, EOS, Golf (Plus) V / VI, Jetta III, Passat B6, Scirocco III, Tiguan
	7.09730.05.0	03L 131 511 A, 03L 131 511 J, 03L 131 511 L, 03L 131 511 Q	Volkswagen	Amarok, Crafter
EGR cooler modules	7.02156.24.0	1618 LC, 9671187780, AV 6Q 9D475 AB, 1 685 740	Citroën, Fiat, Ford, Peugeot, Volvo	Berlingo, C-Elysee, C3 II, C3 Picasso, C4 II, C4 Picasso, C5 III, DS3 / 4 / 5, Jumpy II, Scudo, B-Max, C-Max II, Fiesta VI, Focus III, Mondeo IV
	7.02156.33.0	1626 44, 9800125180, 9671146480, 9800125180, AV6Q-9U433-AA, 1708004, 31319549, 31370621	Citroën, Fiat, Ford, Peugeot, Volvo	Berlingo, C-Elysee, C3 II, C3 Picasso, C4, C4 II, C5 III, DS3 / 4 / 5, Jumpy II, Scudo, C-MAX II, Fiesta VI, Focus III, Grand C-MAX, Mondeo IV
	7.03622.10.0	55230929, 851073, 55278868	Chevrolet, Chrysler, Fiat, Lancia, Opel, Vauxhall	Aveo, Ypsilon, Fiorino, Panda, Qubo, Tipo, 500, 500L, Astra J, Combo, Corsa D, Meriva B, Astra Mk VI, Combo Mk III, Corsa Mk III
	7.05483.25.0	GK2Q-9U438-AB, GK2Q-9U438-AC, GK2Q-9U438-AF, GK2Q-9U438-AG, GK2Q-9U438-AH, 2007718, 2068415, 2215572, 2283246, 2374578	Ford	Ranger, Tourneo, Transit
	7.09720.00.0	03L 131 512 AP, 03L 131 512 AT, 03L 131 512 BB, 03L 131 512 BJ, 03L 131 512 BL, 03L 131 512 CF, 03L 131 512 CH, 03L 131 512 DQ, 03L 131 512 N, 03L 131 527 AX	Audi, Seat, Škoda, Volkswagen	A3, Q3, TT, Alhambra, Altea, Ibiza, Leon, Octavia, Rapid, Superb, Ameo, Beetle, Caddy, EOS, Golf Plus, Golf VI, Jetta III, Jetta IV, Passat, Polo V, Scirocco III, Sharan, Tiguan, Touran
	7.09720.01.0	03L 131 512 AN, 03L 131 512 AS, 03L 131 512 BH, 03L 131 512 CE, 03L 131 512 CG, 03L 131 512 DP, 03L 131 512 M	Audi, Seat, Škoda, Volkswagen	A1, Ibiza IV, Toledo IV, Fabia II, Rapid, Roomster, Polo V, Vento
	7.09720.02.0	03P 131 512 B, 03P 131 512 C, 03P 131 512 D, 03P 131 512 E	Seat, Škoda, Volkswagen	Ibiza IV, Fabia II, Roomster, Polo V
	7.09720.03.0	03L 131 512 BG, 03L 131 512 BQ, 03L 131 512 CD, 03L 131 512 DN, 03L 131 512 DT	Audi, Seat	A4, A5, A6, Q5, Exeo
	7.09720.04.0	03L 131 512 BM, 03L 131 512 CB, 03L 131 512 CC, 03L 131 512 DK, 03L 131 512 DS, 03L 131 512 Q	Volkswagen	Multivan T5 / T6, Transporter T5 / T6
	7.10992.00.0	11 71 7 823 210, 7 823 210	BMW	X1, X3, X4, X5, 1, 2, 3, 4, 5, 6, 7
	7.24809.94.0	9671398180, 9678257280, 1682007, 1751357, 1836229, 1855876, 9M5Q-9D475- CA, 9M5Q-9D475-DA, 9M5Q-9D475-DB, 9M5Q-9D475-DC, SU001-A2453	Citroën, Fiat, Ford, Peugeot, Toyota	C4 I / II, C5 III, C8, DS4 / 5, Jumpy II, Scudo, C-MAX II, Focus III, Galaxy II, Grand C-MAX, Kuga I / II, Mondeo IV, S-MAX, Focus, Mondeo, Expert, RCZ, 3008 I, 308 CC / I, 407, 5008 IV, 508 I, 807, Proace
	EGR combination cooler modules	7.02756.07.0	03L 115 512, 03L 115 512 A, 03L 115 512 C, 03L 115 512 D	Volkswagen
EGR valves	7.00578.12.0	1618 T1, 9656911780, 1427355, 6G9Q 9D475 AA, AJ811155, LR000997, MN982239	Citroën, Fiat, Ford, Jaguar, Lancia, Land Rover, Mitsubishi, Peugeot	C-Crosser, C5 II / III, C6, C8, Ulysse, Galaxy II, Mondeo IV, Discovery, Freelander 2, Range Rover Evoque, Outlander II
	7.00907.03.0	03G 131 502, 03G 131 502 B	Audi, Seat, Škoda, Volkswagen	Ibiza III / IV, Fabia II, Octavia II, Roomster, Caddy III, EOS, Golf V, Passat B6, Touran
	7.01599.10.0	71753846, 55599946, 71753846, 1618 QR, 55216292, 55252380, 555278343, 71753846, 71795160, BS51-9D475-AA, 1724224, 1207101-ED01B, 71753846, 71795160, 55577947, 55599946, 58 51 089, 8 51 045, 8 51 176, 93195431, 18520-63P00, 18520-68L00, 18521-63P00	Alfa Romeo, Chevrolet, Chrysler, Citroën, Fiat, Ford, Great Wall, Haval, Lancia, Opel, Peugeot, Suzuki, Vauxhall	Mito, Aveo, Ypsilon, Nemo, Doblo, Fiorino, (Grande) Punto, Idea, Linea, Panda, Qubo, Strada, Tipo, 500, Ka, Fengjun 5, Wingle 5, H5, Musa, Ypsilon, Astra J, Corsa D, Corsa E, Meriva B, Bipper, Swift IV, Astra Mk VI, Corsa Mk III / IV, Meriva Mk II
	7.02209.11.0	1618 LN, 9467633780, AV6Q-9E456-AA, AV6Q-9E456-BA, 1 696 587, 1 702 178, MN982670, SU001-A0590, 36001458, 36001479, 36001487	Citroën, DS, Fiat, Ford, Mitsubishi, Peugeot, Toyota, Volvo	Berlingo, C-Elysee, C3 II, C3 Picasso, C4 (I / II), C5 III, DS3 / 4 / 5, Grand C4, Ecosport, Fiesta VI, Focus III, Galaxy II, Grand C-MAX, Mondeo IV / V, S-MAX, Tourneo, Transit, ASX, Expert

\* The reference numbers given are for comparison purposes only and must not be used on invoices to the consumer.

Product	Item no.	Ref. no.	Manufacturer	Vehicle examples
EGR valves	7.03784.34.0	980055380, BK2Q-9D475-CB, BK2Q-9D475-CC, BK2Q-9D475-CD, BK2Z-9D475-A, FB3Q-9D475-AA, FB3Q-9D475-AB, FB3Q-9D475-AC, 1 730 360, 1 835 009, 1 895 826, 1 932 037, 2 017 121, 2026142, BK2Q-9d475-CD, LR030027, LR055534, LR081121, U209-20-300B, 1D00-20-300, 1D00-20-300A, 1D00-20-300B	Citroën, Ford, JMC, Land Rover, Mazda, Peugeot	Jumper II, Ranger, Tourneo Custom V362, Transit Bus / Custom V362 / Tourneo / V363, Ranger, Everest, Yuhur, Defender, Defender II, BT-50 II, BT-50, Boxer
	7.04493.17.0	11 71 8 513 132, 11 71 8 580 442, 11 71 8 594 492, 11 71 9 886 715, 8 513 132, 8 580 442, 8 594 492, 9 886 715, 25620-WA020	Alpina, BMW, Mini, Toyota	D5, X1, X2, X3, X4, X5, X6, X, 1, 2, 3, 4, 5, 6, 7, 8, Clubman, Countryman, Paceman, Auris, Avensis, RAV 4 IV, Verso
	7.10334.00.0	03G 131 501, 03G 131 501 P, 03L 131 501 C, 03L 131 501 D, 03L 131 501 E, 03L 131 501 G, 03L 131 501 K	Audi, Seat, Škoda, Volkswagen	A3, A4, A5, A6, Q5, TT, Leon, Octavia II, Superb II, Yeti, Beetle, EOS, Golf V / VI, Jetta III / IV, Passat B6 / B7, Scirocco III, Tiguan, Touran
	7.10334.07.0	11 71 7 805 447, 11 71 7 810 871, 11 71 9 886 714, 7 805 447, 7 810 871, 9 886 714	BMW	X1, X3, X4, X5, X6, 1, 2, 3, 4, 5, 6, 7
	7.22818.57.0	MW30638635, MW30662336, MW30662345, MW30670108, MW30774534, MW30777076, M616666, 14710-AW301, 14710-AW302, 14710-AW303, 14920-00QAD, 14920-00QAE, 14920-00QAF, 14920-00QAG, 14920-00QOB, 44 09 585, 44 11 757, 44 12 632, 44 13 408, 44 15 798, 44 16 575, 44 30 902, 93160003, 93160754, 93161069, 93161219, 93161487, 93183146, 93188701, 77 00 107 797, 82 00 229 190, 82 00 231 630, 82 00 282 880, 82 00 360 200, 82 00 467 001, 82 00 542 997, 36000979	Dacia, Mitsubishi, Nissan, Opel, Renault, Vauxhall, Volvo	Solenzo, Carisma, Space Star, Interstar, Primastar, Movano A, Vivaro A, Clio I / II, Espace IV, Kangoo, Laguna I / II, Master II, Megane I, Trafic II, Movano Mk I, S40 I, V40
	7.24809.16.0	038 131 501 AF, 038 131 501 AN, 038 131 501 S, 68001558AA, 68001558AB, MN980163, MN980265, MN980325, 038 129 637 D, 038 131 501 AF, 038 131 501 AN, 038 131 501 S	Audi, Chrysler, Dodge, Jeep, Mitsubishi, Seat, Škoda, Volkswagen	A3, Outlander II, Altea, Cordoba, Ibiza III, Leon, Fabia I / II, Octavia I / II, Roomster, Superb II, Bora (I), Golf IV / V, Jetta III, Lupo I, New Beetle, Passat B6, Polo IV, Touran
	7.24809.39.0	1618 NR, 1618 59, 96 602 762 80, 96 728 800 80, 1338675, 1439414, 1479057, 1526689, 1682737, 5S6Q-9D475-AA, 5S6Q-9D475-AB, 5S6Q-9D475-AC, 5S6Q-9D475-AD, 5S6Q-9D475-AE, Y605-20-300, Y605-20-300A, Y605-20-300B, Y605-20-300C, 11 71 7 804 950, 18520-69K00, 18520-69K01, 18520-69K02, 31259249, 36000977, 36001412	Citroën, Fiat, Ford, Mazda, Mini, Peugeot, Suzuki, Volvo	Berlingo, C2, C3 (I / II), C4, C5 II / III, Jumpy II, Xsara, Scudo, C-MAX, Fiesta IV / V, Focus C-MAX / II, Fusion, 3, Clubman, Expert, Partner, 1007, 206 (CC / SW), 207 (CC / SW), 3008 I, 307 (SW), 308 CC / I / SW I, 407 SW, 407, 5008, SX4, C30, S40 II, S80 II, V50, V70 III
	7.24809.68.0	1618 GZ, 1618 S8, 71793027, 71793404, 96 566 123 80, 96 818 252 80, 1231964, 1436390, 6M5Q-9D475-AA, 1618 GZ, 1618 S8, 36000980, 36050870	Citroën, Fiat, Ford, Lancia, Peugeot, Volvo	C4 (I), C5 II / III, C8, Jumpy II, Scudo, C-MAX, Focus C-MAX / II, Galaxy II, Kuga I, Mondeo IV, S-MAX, 307 SW, 308 CC / I / SW I, 807, C30, C70 II, S40 I / II, S80 II, V50, V70 III
	7.24809.70.0	1618 HQ, 1618 R5, 71789685, 71793436, 9659694780, 9665752480, 1384616, 1466340, 1480560, 6C1Q-9D475-AF, 6C1Q-9D475-AG, 8C1Q-9D475-BA, LR005369, LR006650	Citroën, Fiat, Ford, Land Rover, Peugeot	Jumper II, Ducato, Transit (Tourneo), Defender, Boxer
	7.24809.90.0	6000616782, 6000620597, 6000620763, A 626 140 00 60, A 626 140 02 60, A 626 140 07 00, A 626 140 08 00, A 626 140 09 00, 626 140 00 60, 626 140 02 60, 626 140 07 00, 626 140 08 00, 626 140 09 00, 1471-000Q0T, 1471-000Q0U, 14710-00Q1B, 1471-000Q1E, 14710-00Q1G, 14710-00Q1L, 95518009, 95518010, 95527051, 95528937, 14 71 014 78R, 14 71 050 39R, 14 71 098 16R, 14 71 099 48R	Fiat, Mercedes-Benz, Mitsubishi, Nissan, Opel, Renault, Vauxhall	Talento, C-Class, Marco Polo, Vito, Express IV, NV300, Qashqai (II), X-Trail (III), Vivaro B, Espace V, Fluence, Grand Scénic III / IV, Kadjar, Koleos II, Megane CC / III / IV, Scénic III / IV, Talisman, Trafic III
	7.28248.17.0	036 131 503 R, 036 131 503 T	Audi, Seat, Škoda, Volkswagen	A2, Ibiza II / III, Leon, Toledo II, Fabia I, Octavia I / II, Bora I, Caddy II / III, Golf IV / V

**We offer a comprehensive product portfolio covering a large number of engines.  
Here are some examples of our best-selling utility vehicles in the aftermarket.**

Product	Item no.	Ref. no.	Manufacturer	Vehicle examples
EGR cooler	7.03692.11.0	QC000384, 580 181 49 14	FUSO	Canter
			Mitsubishi	Canter VI
EGR cooler modules	7.04039.13.0	0412 0377, 0412 1248, 0412 3084	Deutz	
	7.04433.02.0	0413 3012	Deutz	
	7.04448.18.0	0451 4020, 0451 6121, 0451 6372	Deutz	
	7.04723.10.0	0491 4700, 0491 5797	Deutz	
	7.04784.06.0	0451 4700, 0451 6128, 0451 6980	Deutz	
	7.04788.06.0	0451 2727, 0451 6210	Deutz	
	7.05107.12.0	0451 4702, 0451 6118, 0451 6172	Deutz	
	7.05337.03.0	0413 3060	Deutz	
EGR valves	7.01268.03.0	A 904 140 00 60, 904 140 00 60	Mercedes-Benz	Actros III, Actros MP2 / MP3, Actros MP4 / MP5, Antos, Arocs
		51.08150-0029	Neoplan Bus	Airliner, Centroliner, Cityliner II, Euroliner, Tourliner, Trendliner
		51.08150-0029	MAN	BUS, CLA, FOC, HOCL, Lion'S, L2000, M 2000 L, M 2000 M, NG, NL, NM, NÜ, Series RH, SG, SL II, SÜ, TGA, TGL I, TGM I, TGS I, TGX I, ÜL, 18T Series
	7.03379.03.0	0426 5310	Deutz	
	7.03390.09.0	4795919	Caterpillar	
	7.03391.11.0	4667874	Caterpillar	Backhoe Loader, Paving Compactor, Telehandler, Track Type Tractor, Wheel Type Loader
	7.03527.12.0	0450 9500, 0451 6694	Deutz	
	7.03761.09.0	4795920	Caterpillar	Asphalt Pavers, Excavator, Forest Machines, Motor Grader, Wheel Type Loader
	7.03762.10.0	4667875	Caterpillar	Asphalt Pavers, Backhoe Loader, Excavator, Paving Compactor, Telehandler, Track Type Tractor
	7.03803.03.0	RE544319	John Deere	
	7.03808.69.0	1896001, 1952321, 1954013, 1960471, 2021932, 2104972, 2128862, 2162361, 2200141, 2426260	DAF	CF, CF 85, XF, XF 105
	7.04255.67.0	2123990, 2128145, 2162360, 2256370, 2339622, 2412200	DAF	CF, XF, XF II
	7.04256.35.0	0412 0012, 0412 0412, 0412 3212	Deutz	
	7.04256.36.0	0413 0812, 0413 3023, 0413 4412	Deutz	
	7.04256.42.0	0412 1508, 0421 0822	Deutz	
	7.04371.07.0	0412 5434	Deutz	
	7.04382.09.0	0450 9502, 0451 0628	Deutz	
	7.04723.12.0	0451 6700	Deutz	
	7.04787.12.0	0491 5700, 0491 5830, 0491 5962	Deutz	
	7.05454.07.0		Fendt	Vario
		51.08150-0070, 51.08150-0076	MAN	HOCL, Lion'S Coach, TGS I
	7.05506.14.0		SAME	Fortis
			Fendt	Vario
		0451 3698, 0451 4444, 0451 6696	Deutz	Series 6
	7.05632.04.0		FUSO	Canter
	7.08797.40.0	2243011, 2339640, 2418868	DAF	XD, XF, XG
	7.22841.08.0	51.08150-0011, 51.08150-6014, 51.08150-6019	MAN	E2000, F2000, Lion'S Star, Series FE, RHC, RHS, TG, TGA, 18T, 23T, 24T, 26T, 27T, 28T, 29, 30T, 32T, 33T, 35T, 40T, 41T, 42T, 50T Series
	7.22946.34.0		Zetor	Proxima

**HEADQUARTERS:**

**MS Motorservice International GmbH**

Wilhelm-Maybach-Straße 14–18

74196 Neuenstadt, Germany

[www.ms-motorservice.com](http://www.ms-motorservice.com)

[www.rheinmetall.com](http://www.rheinmetall.com)

© MS Motorservice International GmbH – 50003956-02 – EN – 02/2025 (022025)

