

MONTAGEANLEITUNG
ARBEITSSCHEINWERFER
INSTALLATION INSTRUCTION
WORK LAMP
INSTRUCTIONS DE MONTAGE
PROJECTEUR DE TRAVAIL
MONTERINGSANVISNING
ARBETSSTRÅLKASTARE
MONTAGEHANDLEIDING
WERKLAMP
INSTRUCCIONES DE MONTAJE
FARO DE TRABAJO
ISTRUZIONI DI MONTAGGIO
FARO DE LAVORO
ASENNUSOHJE
TYÖVALONEHEITINTÄ

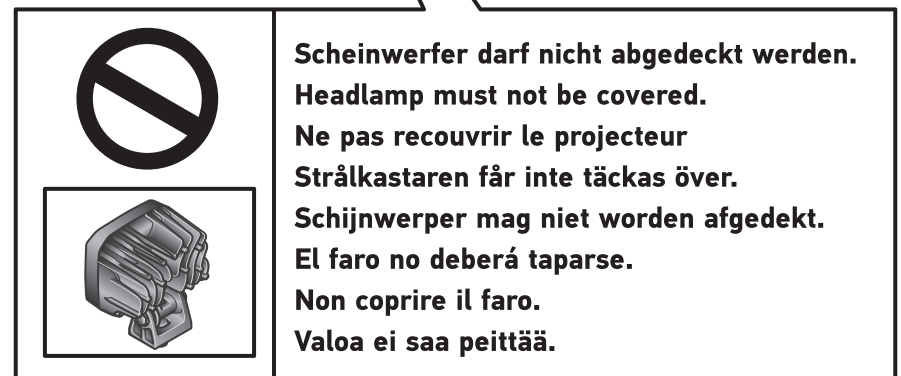
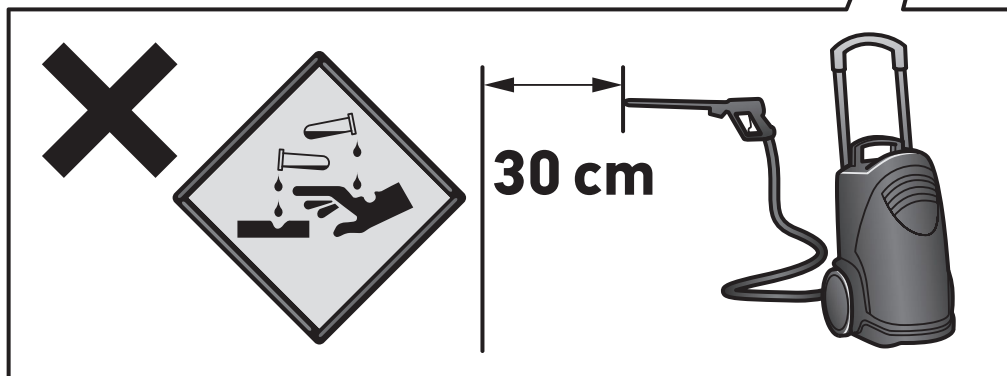
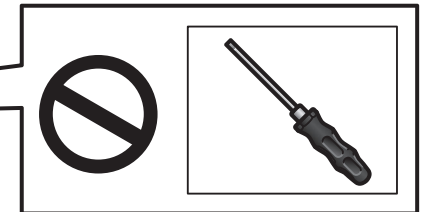
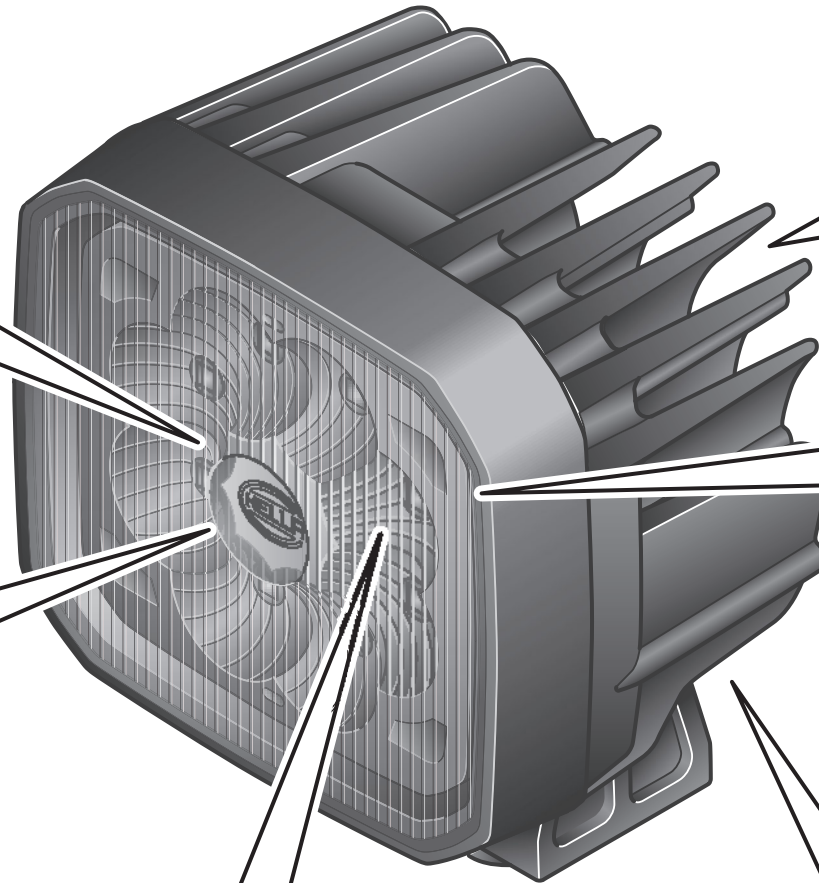
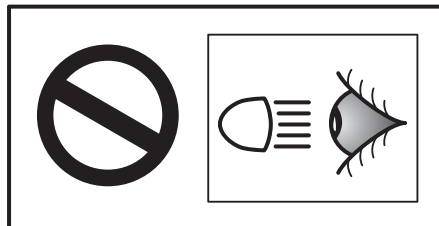
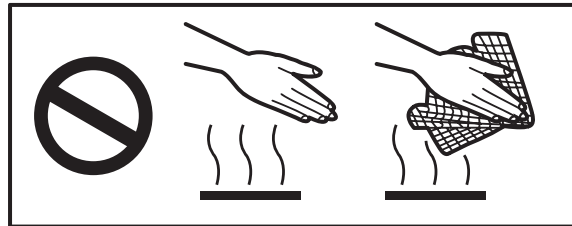

DE PRODUKTHAFTUNG

- Es sind die nationalen Anbau-, Einbau- und Betriebsvorschriften zu beachten und einzuhalten.
- Lesen Sie bitte vor Gebrauch des Gerätes alle beigelegten Anleitungen und Sicherheits-hinweise.
- Im Zuge von Produktverbesserung behalten wir uns technische und optische Änderungen vor.
- Verwenden Sie nur die Originalersatzteile bzw. nur Ersatzteile die von HELLA freigegeben sind.
- Bei Fragen oder Einbauproblemen, wenden Sie sich bitte an den HELLA Kundendienst, den Großhändler oder an Ihre Werkstatt.
- Weitere Informationen finden Sie auch auf unserer Internetseite (www.hella.com/techworld)

EN PRODUCT LIABILITY

- National mounting, fitting and operating regulations must be heeded and kept.
- Please read all the instructions and safety notes included before using the device.
- We reserve the right to make technical and optical modifications within the course of product improvement.
- Only use original spare parts or spare parts approved by HELLA.
- If you have any questions or problems with the installation, please contact HELLA Customer Services, a wholesaler or your garage.
- Further information is available on our website (www.hella.com/techworld)

FR RESPONSABILITÉ PRODUIT

- Les prescriptions nationales en matière de montage et de service doivent être observées et respectées.
- Avant d'utiliser l'appareil lire toutes les instructions de montage et de service fournies ainsi que les conseils de sécurité.
- Dans le cadre de l'amélioration continue de nos produits, nous nous réservons le droit de réaliser des modifications sur les plans technique et optique.
- Utilisez uniquement des pièces d'origine ou des pièces de rechange validées par HELLA.
- Pour toute question ou en cas de problèmes de montage, veuillez contacter le S.A.V. ou le distributeur HELLA ou bien vous adresser à votre garagiste.
- Vous trouverez également des informations complémentaires sur notre site Internet (www.hella.com/techworld)

SV **PRODUKTANSVAR**

- De nationella monterings-, installations- och driftföreskrifterna ska beaktas och följas.
- Läs alla medföljande instruktioner och säkerhetsanvisningar innan du använder apparaten.
- Vi förbehåller oss rätten till tekniska och optiska ändringar som förbättrar produkten.
- Använd endast original reservdelar resp. endast reservdelar som har godkänts av HELLA.
- Vid frågor eller monteringsproblem, kontakta HELLA kundtjänst, grossisten eller din verkstad.
- Mer information finns också på vår webbplats (www.hella.com/techworld)

NL **PRODUCTAANSPRAKELIJKHEID**

- Men dient de nationale aanbouw-, inbouw- en bedrijfsvoorschriften in acht te nemen en na te leven.
- Lees a.u.b. alvorens het apparaat te gebruiken alle bijgevoegde gebruiksaanwijzingen en veiligheidsinstructies door.
- In het kader van de productver-betering behouden wij ons technische en optische veranderingen voor.
- Gebruik uitsluitend de originele reserveonderdelen, die door Hella vrijgegeven zijn.
- Neem bij vragen of inbouwproblemen contact op met de HELLA klantenservice, de groothandel of het garagebedrijf.
- Meer informatie is ook te vinden op onze website (www.hella.com/techworld)

ES **RESPONSABILIDAD CIVIL POR PRODUCTOS DEFECTUOSOS**

- Tienen que observarse y cumplirse con las prescripciones nacionales sobre construcciones anexas, de montaje y de funcionamiento.
- Rogamos que antes de usar el aparato lean todas las instrucciones y advertencias sobre la seguridad adjuntas.
- En aras de la mejora de los productos, nos reservamos el derecho de hacer modificaciones técnicas y ópticas.
- Use sólo recambios originales o bien sólo recambios autorizados por HELLA.
- En caso de dudas o preguntas a la hora del montaje, llame al servicio de atención al cliente de HELLA o diríjase a su Distribuidor o Taller.
- Encontrará más información en nuestra página web (www.hella.com/techworld)

IT**RESPONSABILITÀ PER IL PRODOTTO**

- Si devono rispettare tutte le normative nazionali di attacco, montaggio e funzionamento.
- Prima di usare l'apparecchio, legga per favore tutte le istruzioni e le avvertenze di sicurezza allegate.
- Nell'ambito del perfezionamento del prodotto, ci riserviamo modifiche tecniche ed estetiche.
- Utilizzare solo pezzi di ricambio originali risp. pezzi autorizzati dalla HELLA.
- Per eventuali domande o problemi di installazione contattare l'Assistenza Clienti HELLA, il grossista o rivolgersi alla propria officina.
- Ulteriori informazioni sono disponibili anche sul nostro sito web (www.hella.com/techworld)

FI**TUOTEVASTUU**

- Kansalliset asennus- ja käyttöohjeet on huomioitava ja niitä on noudatettava.
- Lue ennen laitteen käyttöä kaikki oheistetut käyttö- sekä turvaohjeet.
- Jatkuvasta tuotekehittelystä johtuen pidätämme oikeuden teknisiin ja optisiin muutoksiin.
- Käytä vain alkuperäisiä tai HELLA hyväksymiä varaosia.
- Jos sinulla on kysyttävää tai asennusongelmia, käänny HELLA-asiakaspalvelun, tukkuliikkeen tai korjaamon puoleen.
- Lisätietoja löytyy verkkosivustoltamme (www.hella.com/techworld).

DE Technische Änderungen vorbehalten

EN Subject to alteration without notice

FR Sous réserve de modifications techniques

SV Vi reserverar oss för tekniska ändringar

NL Technische wijzigingen voorbehouden

ES Reservadas modificaciones técnicas

IT Con riserva di modifiche tecniche

FI Oikeus teknisiin muutoksiin pidätetään

Zeichenerklärung
Explanation symbols
Explication des symboles

Symbolförklaring
Legenda
Aclaración de símbolos

Legenda
Piirroksen selitys



DE	Richtig
EN	Correct
FR	Correct
SV	Rätt
NL	Goed
ES	Correcto
IT	Giusto
FI	Oikein



DE	Falsch
EN	Incorrect
FR	Incorrect
SV	Fel
NL	Fout
ES	Erróneo
IT	Sbagliato
FI	Väärin



DE	Positionspfeil
EN	Location/Position Arrow
FR	Flèche de Position
SV	Positionpil
NL	Lokatie/Positie pijl
ES	Flecha de posición
IT	Freccia di posizione
FI	Paikannusnuoli



DE	Bewegungspfeil
EN	Movement Arrow
FR	Flèche indiquant sens du vouvement
SV	Rörelsepil
NL	Richtingspijl
ES	Flecha de moviemento
IT	Freccia di movimentov
FI	Liikesuuntanuoli



DE	Achtung
EN	Warning
FR	Attention
SV	Varning
NL	Let op
ES	Atención
IT	Attenzione
FI	Huomio



DE	Abklemmen
EN	Disconnect
FR	Déconnecter
SV	Koppla los
NL	Demonderen
ES	Desconectar
IT	Staccare
FI	Irrota



DE	Verbinden
EN	Connect
FR	Connecter
SV	Ansult
NL	In elkaar
ES	Conectar
IT	Collegare
FI	Yhdistä

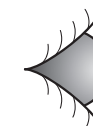

DE	Siehe
EN	Look/See
FR	Voir
SV	Se
NL	Kikjken naar
ES	Ver
IT	Vedere
FI	Katso

Lieferumfang
Scope of delivery
Furniture

Leveransomfattning
Leveringsomvang
Alcance de suministro

Contenuto della confezione
Toimituksen sisältö

1GA 995 706-0XX
1GA 995 706-1XX
1GA 995 706-2XX
1GA 995 706-3XX
1GA 995 706-4XX

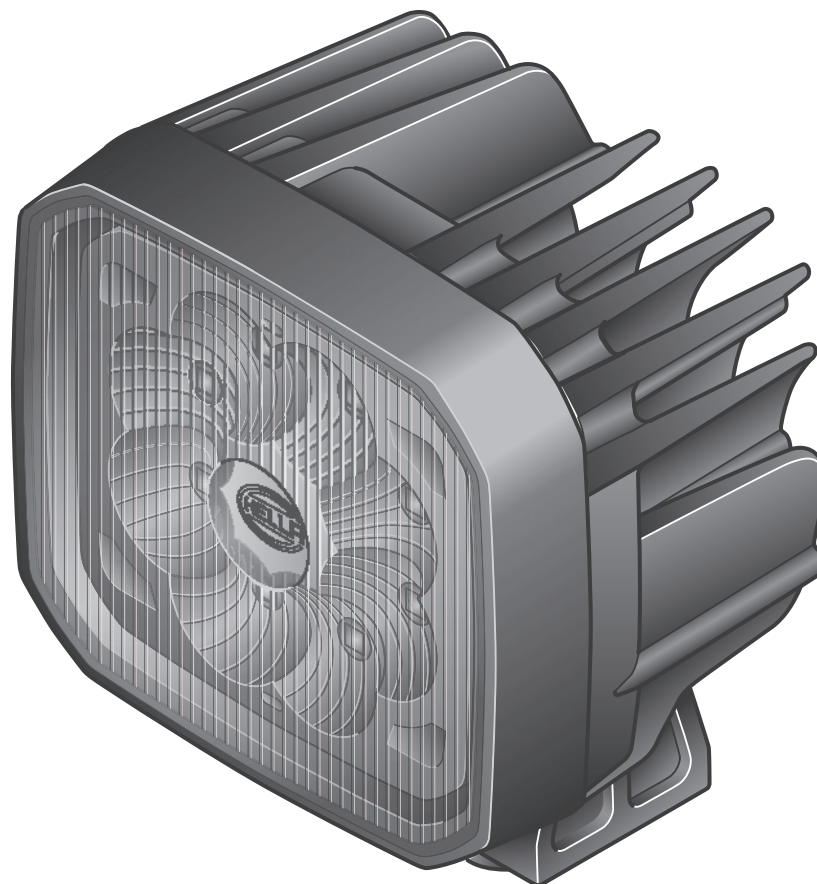

**Zubehör
Accessories
Accessories**

**Tillbehör
Toebehoren
Accessorios**

**Accessori
Lisätarvikkeet**



6EH 007 946-001

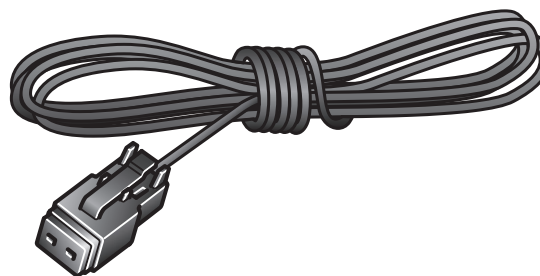

DEUTSCH: 8KB 990 299-011

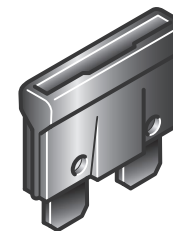

**5A 8JS 711 684 - 821
7,5A 8JS 711 685 - 821**

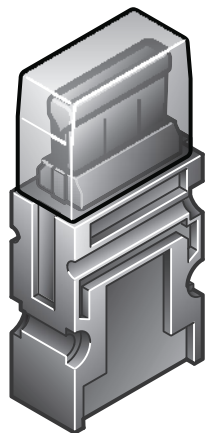

8JD 005 235-801

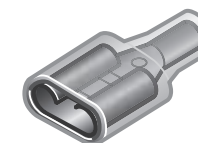

8KW 732 567-003

Benötigte Montagewerkzeuge
Installation tools required
Outils de montage requis

Nödvändiga monteringsverktyg
Benodigde montagewerktuigen
Herramientas de montaje necesarias

Attrezzi necessari per il montaggio
Tarvittavat asennustyökalut



10, 13, 16, 17



Ø10,5 mm

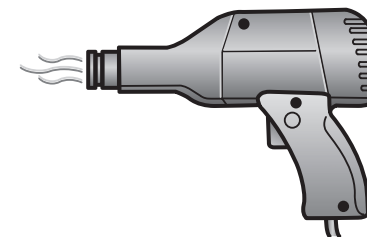
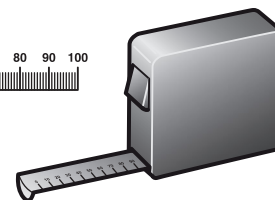
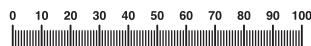
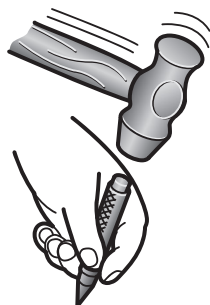
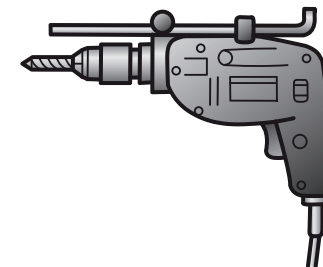
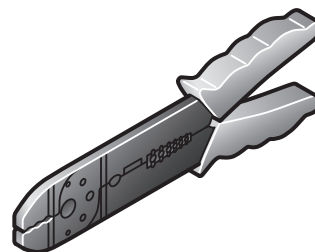
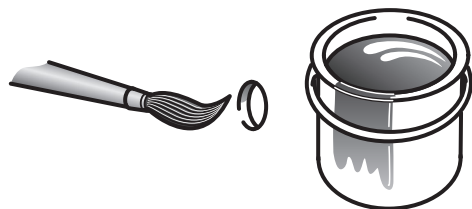

Montage
Mounting
Montage Général

Montering
Montage
Montaje

Montaggio
Asennus

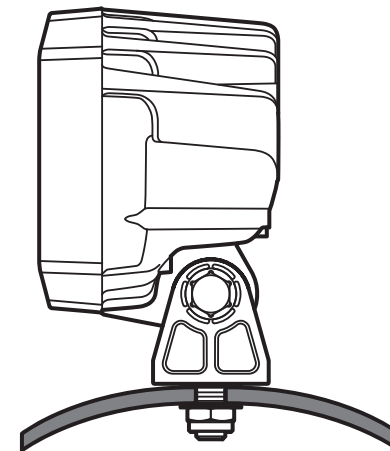
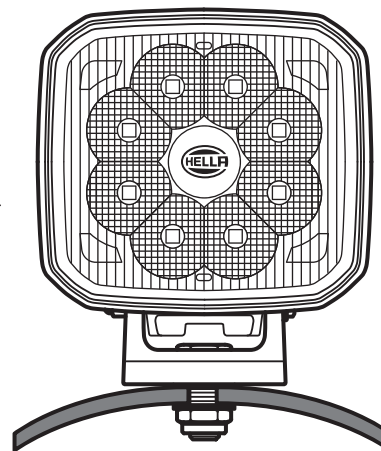
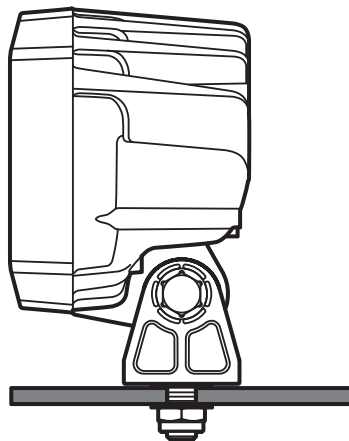
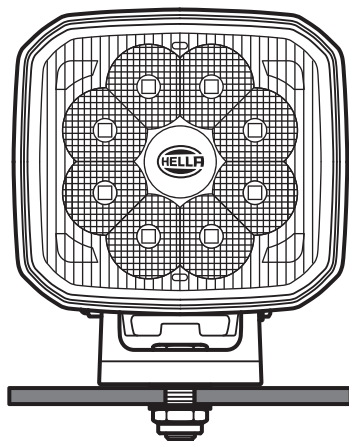
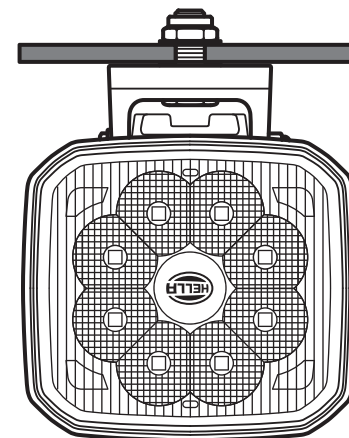
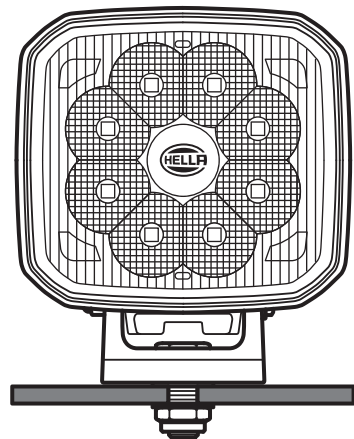

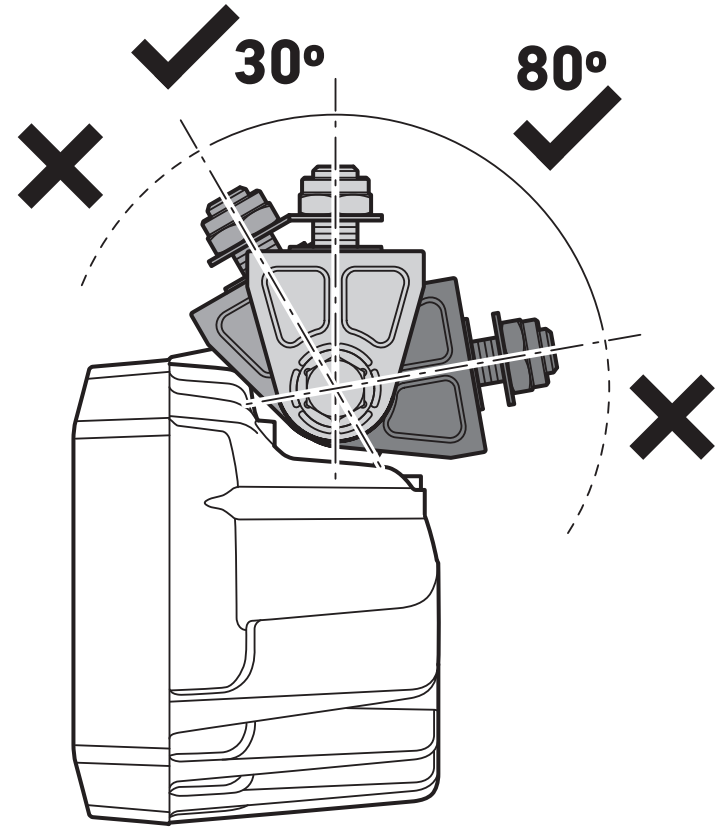
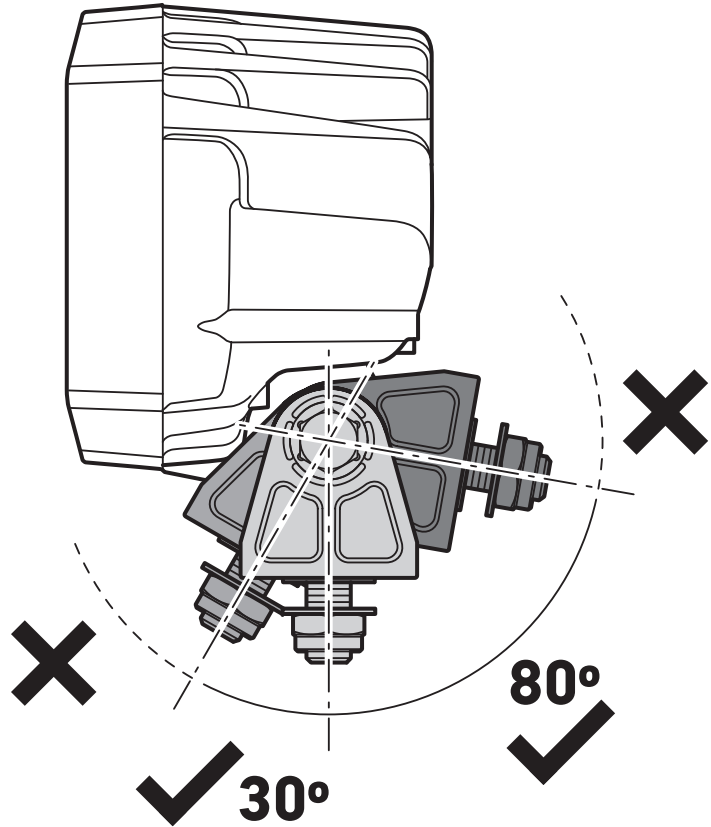

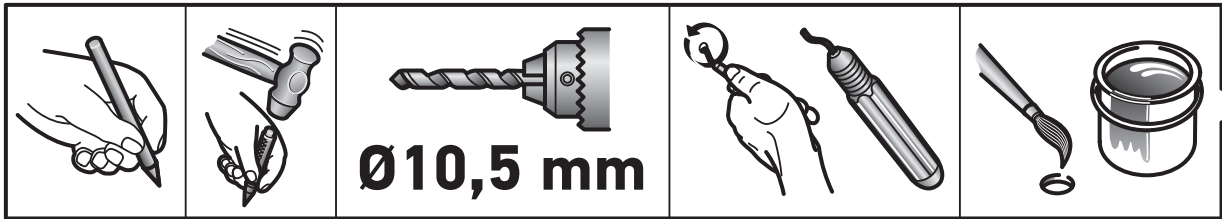
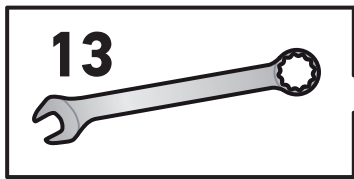
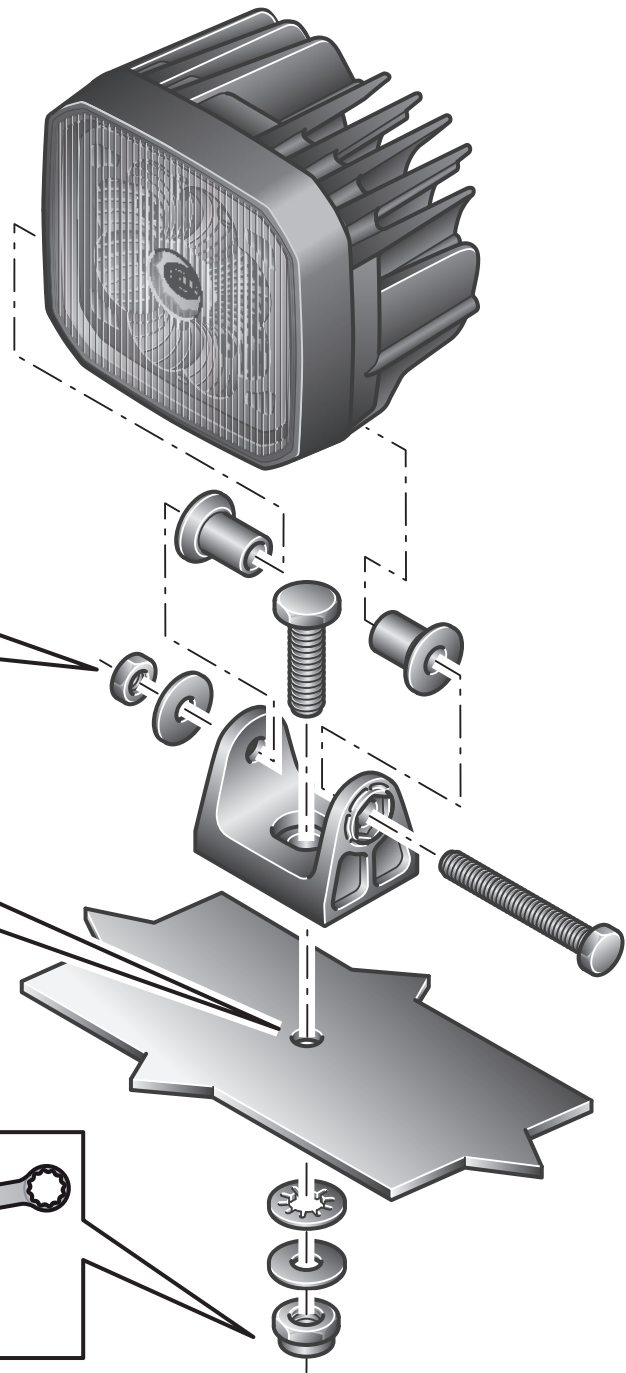

Elektrischer Anschluss
Electrical connection
Branchement électrique

Elektrisk anslutning
Elektrische aansluiting
Conexión eléctrica

Collegamento elettrico
Osaluettelo

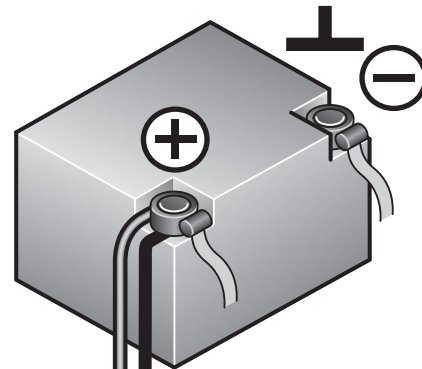
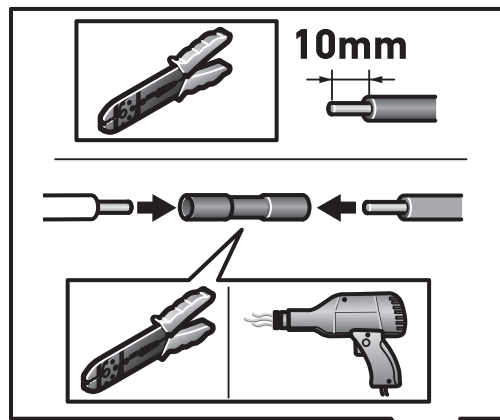

1GA 995 706-0XX	12V	7,5A
1GA 995 706-1XX		
1GA 995 706-2XX	24V	5A
1GA 995 706-3XX		
1GA 995 706-4XX		

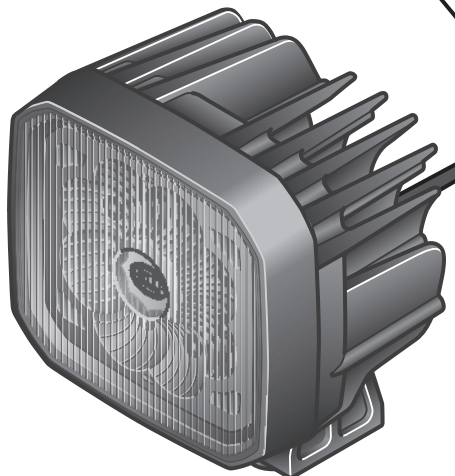
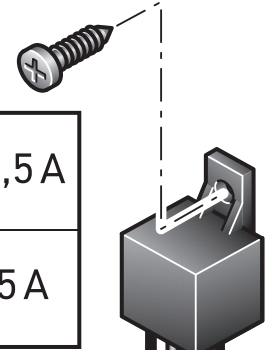

schwarz
black
noir
svart

zwart
negro
nero
musta

weiß
white
blanc
vit

wit
blanco
bianco
valkoinen

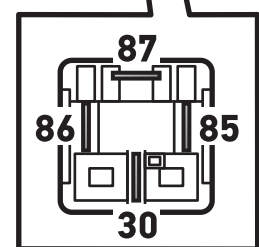
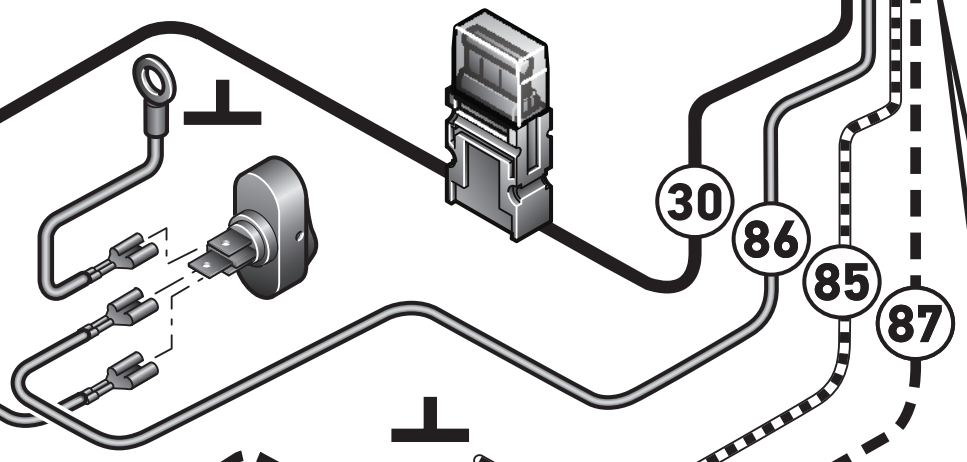

Elektrischer Anschluss
Electrical connection
Branchement électrique

Elektrisk anslutning
Elektrische aansluiting
Conexión eléctrica

Collegamento elettrico
Osaluettelo

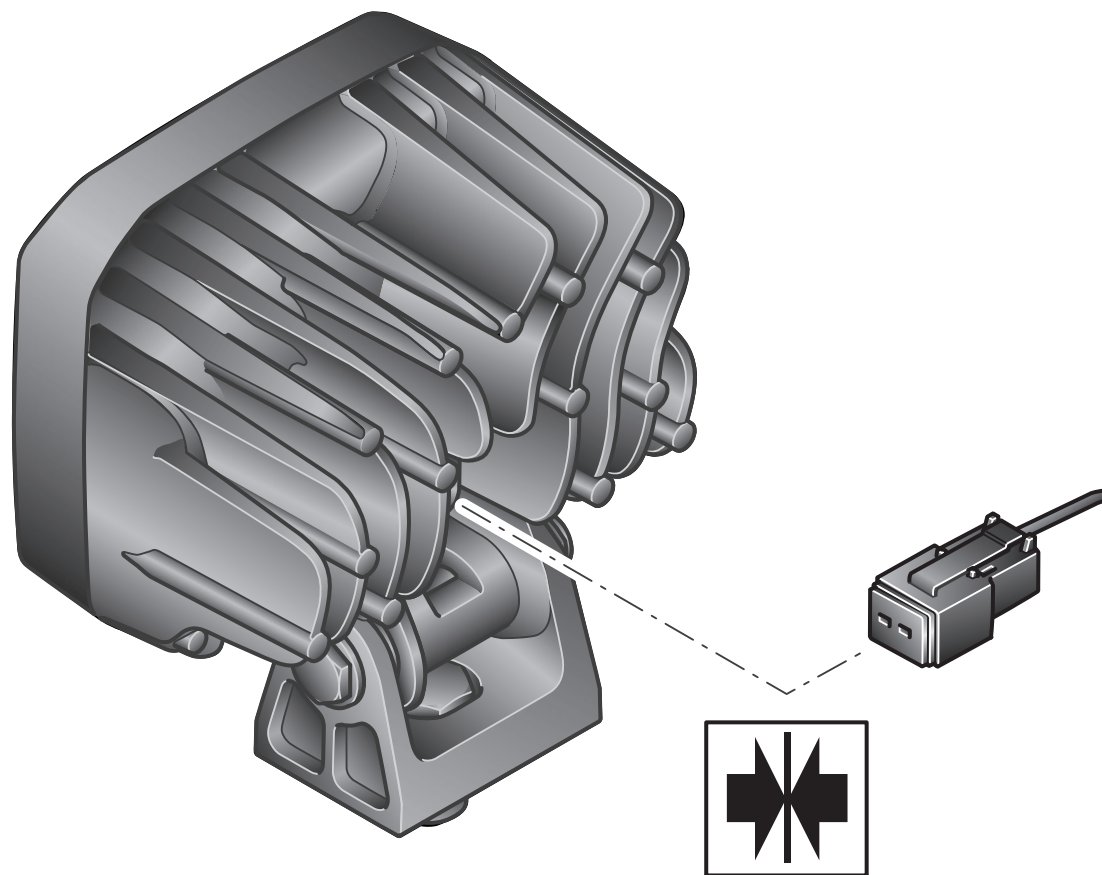

DE	Informationstext	17
EN	Information Text	17
FR	Texte d'information	17
SV	Informationstext	18
NL	Informatie tekst	18
ES	Texto informativo	18
IT	Informazioni	19
FI	Ohjetekstit	19

DE TECHNISCHE DATEN

	Nennspannung	Spannungsbereich	Eingangswerte	Zulässige Umgebungstemperatur	Schutzklasse
1GA 995 706- 0XX/1XX/2XX/3XX/4XX	12V	9V - 32V	< 5A < 45W	-40° C bis +85° C (Überhitzungsschutz)	IP 6K 9K IP 6K 8
	24V		< 2,5A < 40W		

Der Betrieb der Leuchte mit Wechselspannung oder getakteter Gleichspannung ist nicht zulässig!

EN TECHNICAL DATA

	Nominal voltage	Range of voltage	Input values	Admissible ambient temperature	Class of protection
1GA 995 706- 0XX/1XX/2XX/3XX/4XX	12V	9V - 32V	< 5A < 45W	-40°C up to +85°C (overheat protection)	IP 6K 9K IP 6K 8
	24V		< 2,5A < 40W		

Operation of the light using alternating voltage or clocked direct voltage is not permitted!

FR DOCUMENT TECHNIQUE

	Tension nominale	Plage de tension	Valeurs d'entrée	Température ambiante admissible	Classe de protection
1GA 995 706- 0XX/1XX/2XX/3XX/4XX	12V	9V - 32V	< 5A < 45W	-40°C à +85°C (protection contre la surchauffe)	IP 6K 9K IP 6K 8
	24V		< 2,5A < 40W		

Le fonctionnement du feu avec une tension alternative ou une tension continue cadencée n'est pas admis!

SV TEKNISKA DATA

	Märk-spänning	Spänning-sområde	Ingångsvärden	Tillåten omgivningstemperatur	Skyddsklass
1GA 995 706- 0XX/1XX/2XX/3XX/4XX	12V	9V - 32V	< 5A < 45W	-40°C upp till +85°C (överhettningsskydd)	IP 6K 9K IP 6K 8
	24V		< 2,5A < 40W		

Lampan får inte användas med växelspanning eller taktad likspänning!

NL TECHNISCHE GEGEVENS

	Nominale spanning	Spannings-bereik	Ingang-swaarden	Toegestane omgevingstemperatuur	Bescherm-klasse
1GA 995 706- 0XX/1XX/2XX/3XX/4XX	12V	9V - 32V	< 5A < 45W	-40°C tot +85°C (bescherming tegen oververhitting)	IP 6K 9K IP 6K 8
	24V		< 2,5A < 40W		

Het gebruik van de lamp met wisselspanning of getacte gelijkspanning is niet toegestaan!

ES DATOS TÉCNICOS

	Tensión nominal	Margen de tensión	Valores de entrada	Temperatura ambiente admisible	Clase de protección
1GA 995 706- 0XX/1XX/2XX/3XX/4XX	12V	9V - 32V	< 5A < 45W	-40°C hasta +85°C (protección contra sobrecalentamiento)	IP 6K 9K IP 6K 8
	24V		< 2,5A < 40W		

¡No es admisible el funcionamiento de las luces con corriente alterna o corriente continua sincronizada!

IT**DATI TECNICI**

	Tensione nominale	Intervallo di tensione	Valori di ingresso	Temperatura ambiente ammessa	Categoria di protezione
1GA 995 706- 0XX/1XX/2XX/3XX/4XX	12V	9V - 32V	< 5A < 45W	da -40°C a +85°C (protezione da surriscaldamento)	IP 6K 9K IP 6K 8
	24V		< 2,5A < 40W		

Non è consentito attivare i fanali con tensione alternata o tensione continua ciclica!

FI**TEKNISET TIEDOT**

	Nimellis-jännite	Jännitealue	Tuloarvot	Sallittu ympäristölämpötila	Kotelointiluokka
1GA 995 706- 0XX/1XX/2XX/3XX/4XX	12V	9V - 32V	< 5A < 45W	-40°C ... +85°C (ylikuumenemis-suoja)	IP 6K 9K IP 6K 8
	24V		< 2,5A < 40W		

Valoa ei saa käyttää vaihtojännitteellä eikä tahdistetulla tasajännitteellä!

DE Beleuchtungsanlage auf einwandfreie Funktion hin prüfen

EN Check that the lighting system is working perfectly

FR Contrôler le bon fonctionnement de l'installation d'éclairage

SV Kontrollera att ljussystemet fungerar felfritt

NL Controleer of de verlichting goed functioneert

ES Comprobar que el sistema de iluminación funciona impecablemente

IT Controllare la perfetta funzionalità dell'impianto di illuminazione

FI Tarkasta valaistusjärjestelmän toiminta

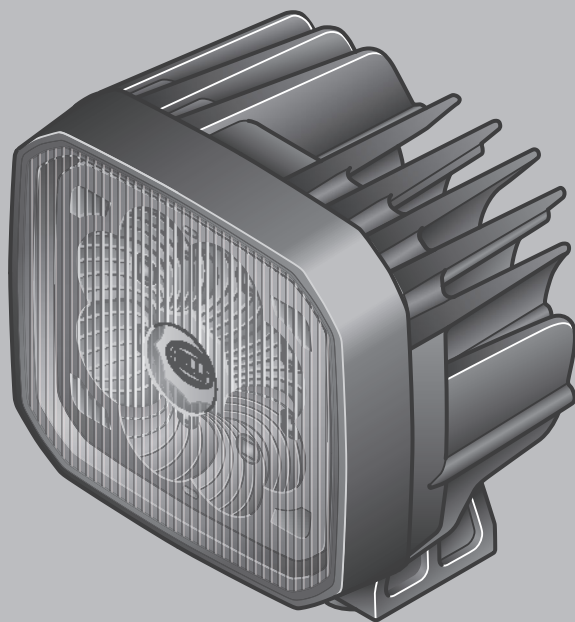

HELLA GmbH & Co. KGaA

Rixbecker Straße 75

59552 Lippstadt /Germany

www.hella.com

© HELLA GmbH & Co. KGaA, Lippstadt

460 879-57 /06.23