



HYUNDAI i20
Active

[2015-2020]









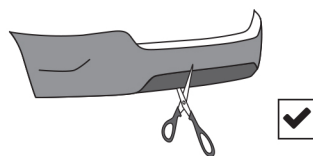



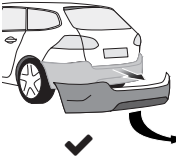
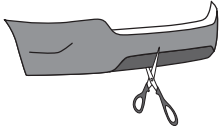

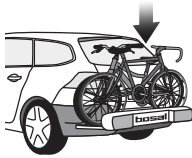



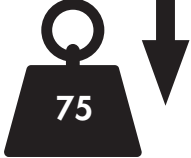
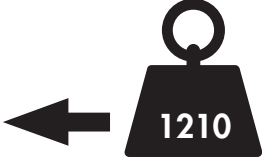







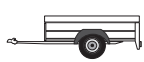

KIA RIO
B/GPL, NO GT Line

[2017+]

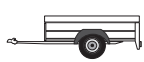



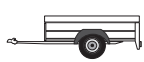

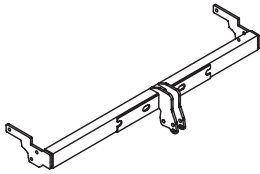
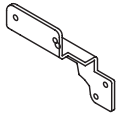
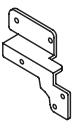

Part Number: 551-781

Type Number: 551-781



  	  	  											
 	 												
													
	E3*55R-01*7888*01 Regolamento UN/ECE 55.01												
 	<table border="0"> <tr> <td>M6 = 10</td> <td>M12 = 85</td> </tr> <tr> <td>M8 = 25</td> <td>M14 = 135</td> </tr> <tr> <td>M10 = 55</td> <td>M16 = 200</td> </tr> </table>		M6 = 10	M12 = 85	M8 = 25	M14 = 135	M10 = 55	M16 = 200					
M6 = 10	M12 = 85												
M8 = 25	M14 = 135												
M10 = 55	M16 = 200												
 	<table border="0"> <tr> <td>MAX ↓ kg</td> <td>MAX ↓ kg</td> <td rowspan="2">X 0,0098' ≤ 6,9</td> </tr> <tr> <td> X </td> <td></td> </tr> <tr> <td>MAX ↓ kg</td> <td>MAX ↓ kg</td> <td></td> </tr> <tr> <td> X </td> <td></td> <td></td> </tr> </table>		MAX ↓ kg	MAX ↓ kg	X 0,0098' ≤ 6,9	 X 		MAX ↓ kg	MAX ↓ kg		 X 		
MAX ↓ kg	MAX ↓ kg	X 0,0098' ≤ 6,9											
 X 													
MAX ↓ kg	MAX ↓ kg												
 X 													
	1H00												

A	1 x	084502520300150000	
B	1 x	084502530500650000	
C	1 x	084502530600750000	

1*	4 x	M12x35x1.25 (8.8)	
2*	4 x	12.2x27x2,5	
1**	4 x	M10x35x1.25 (8.8)	
2**	4 x	10.2x22x2	
2	6 x	M10x35 (8.8)	
3	6 x	10.2x22x2	
4	6 x	M10 (8.8)	
5		M12	

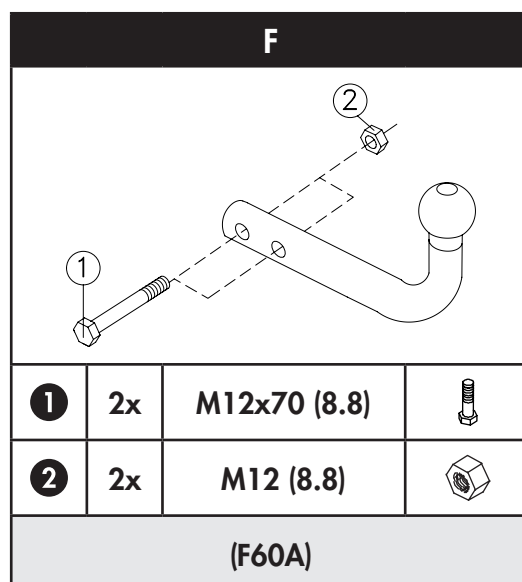

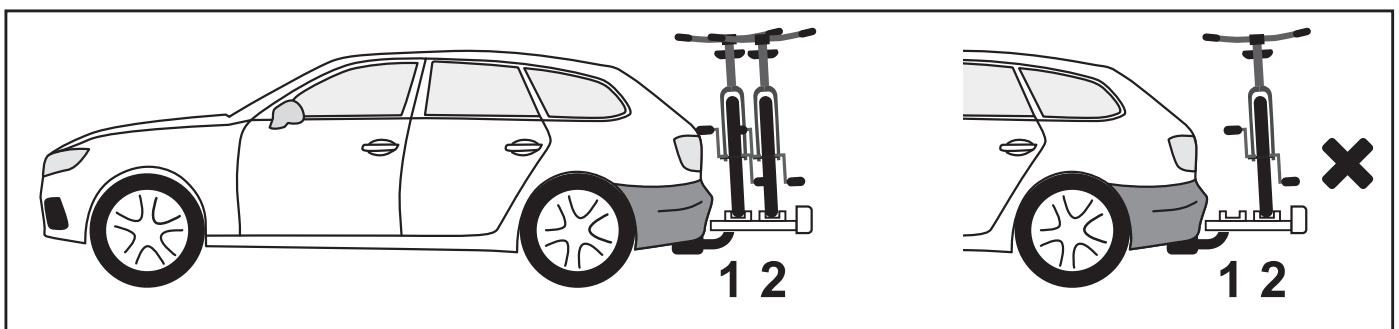
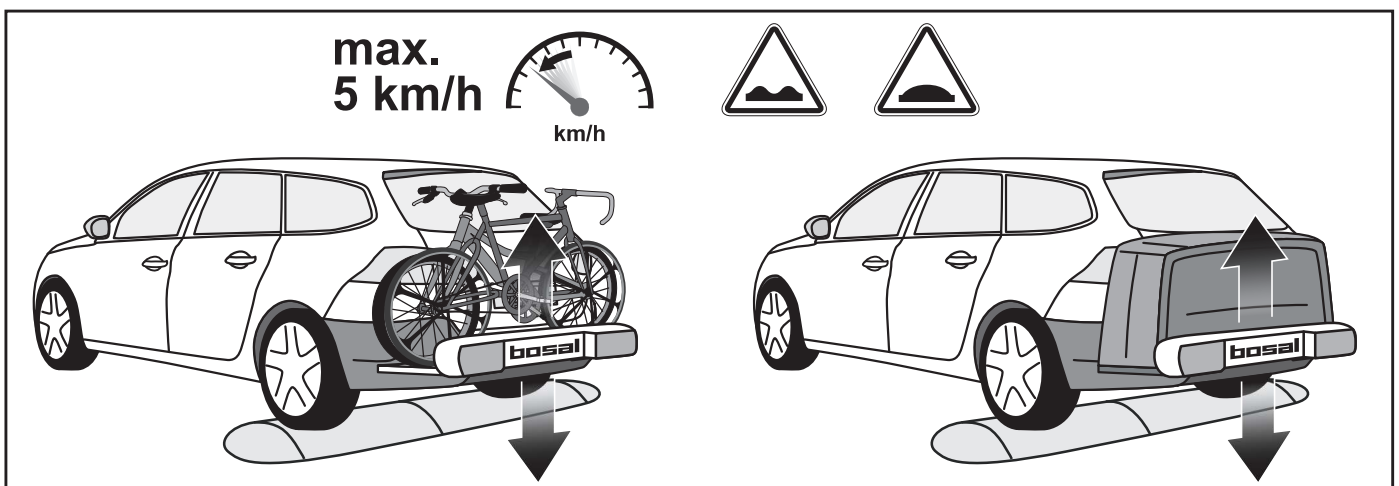
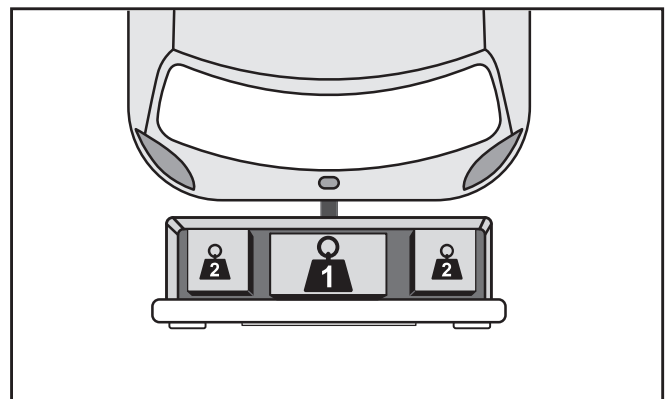
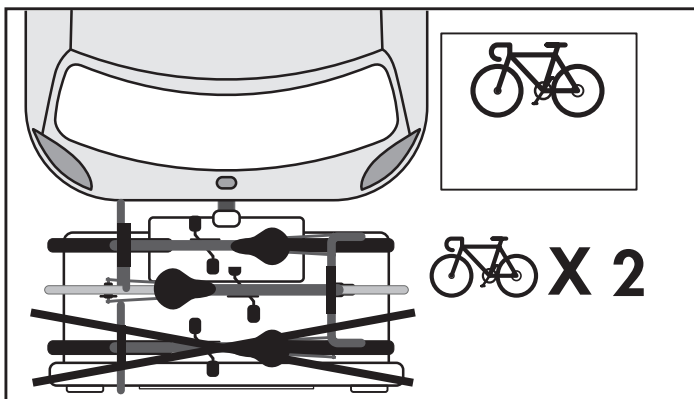
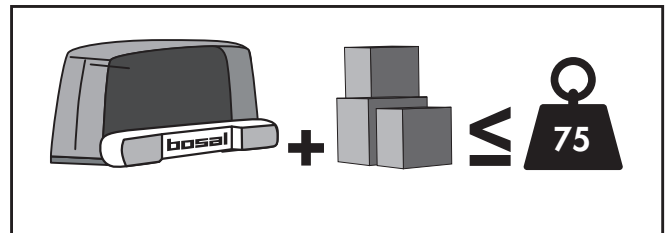
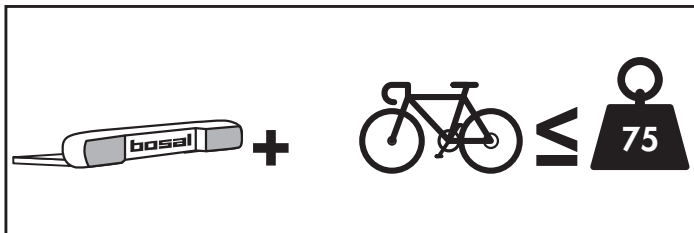
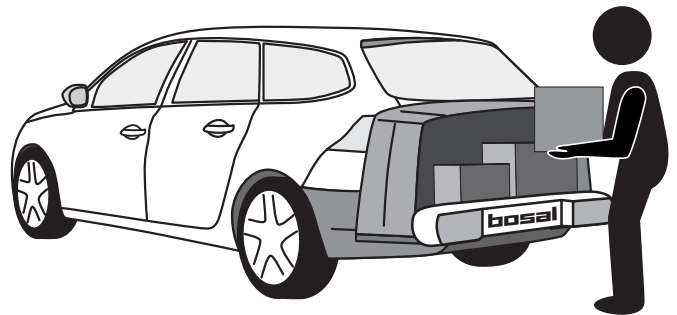
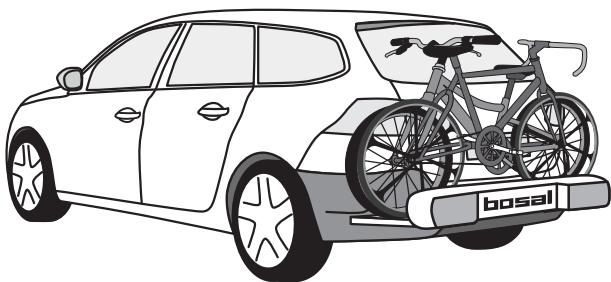

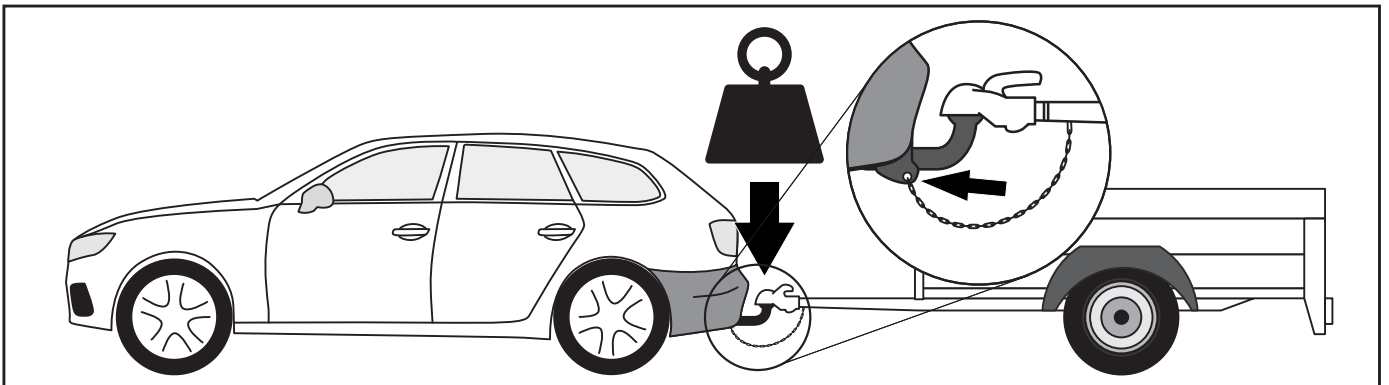
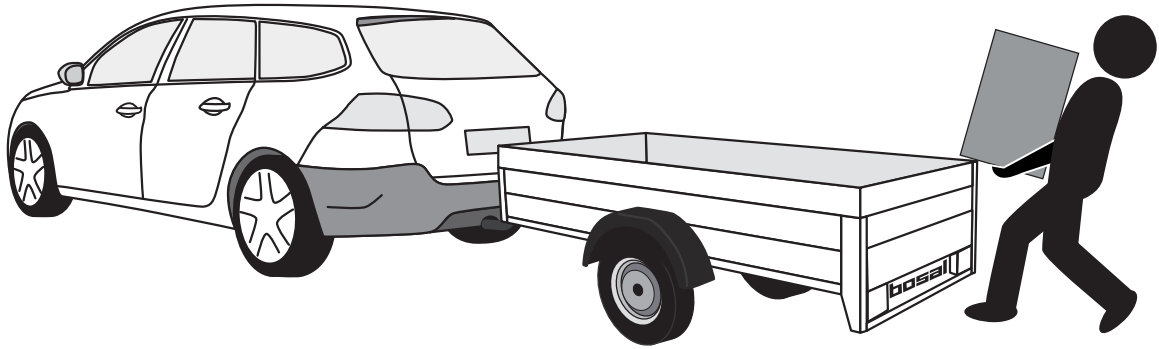

HYUNDAI i20

KIA RIO

1* 2*

1** 2**

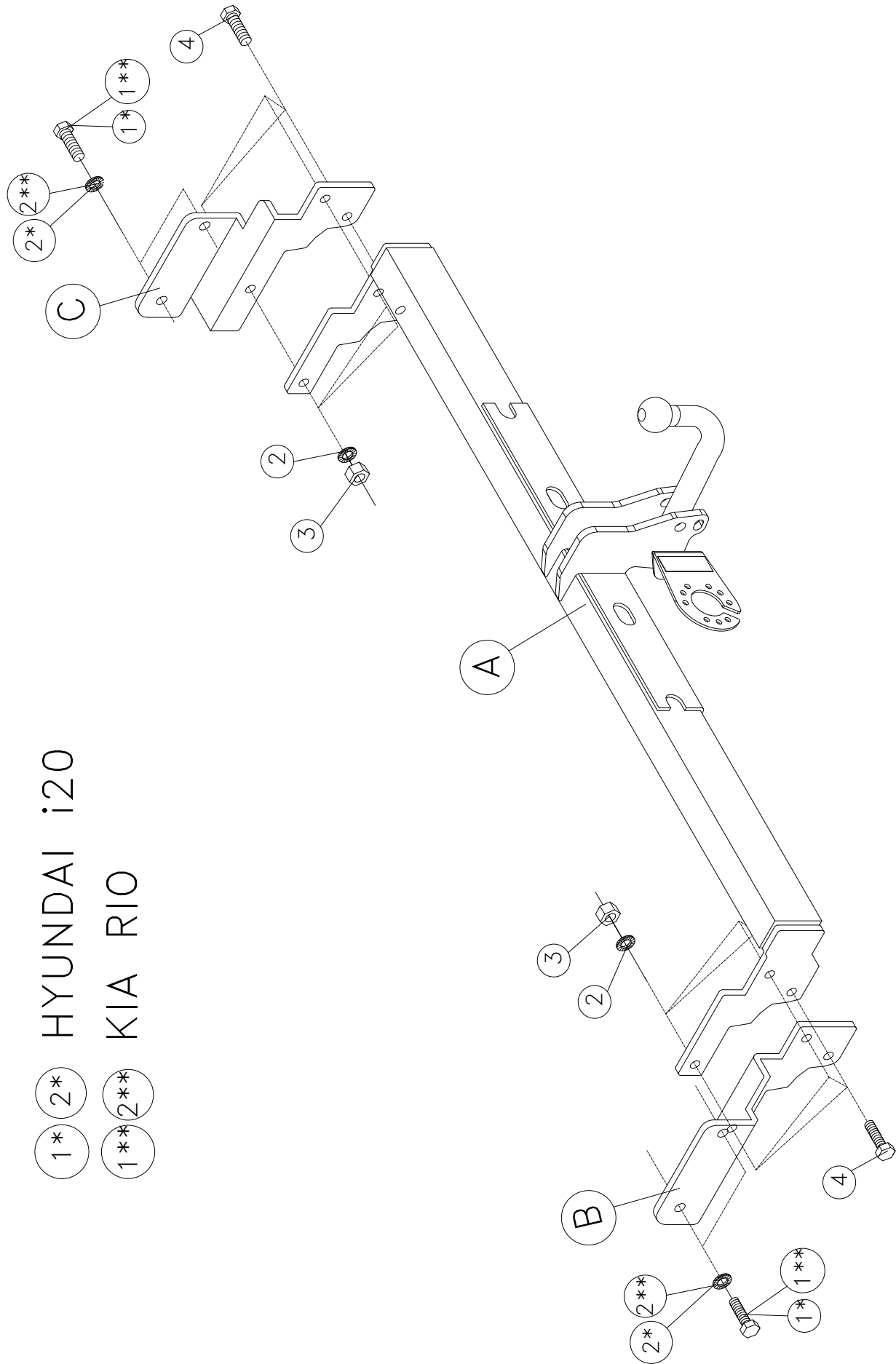

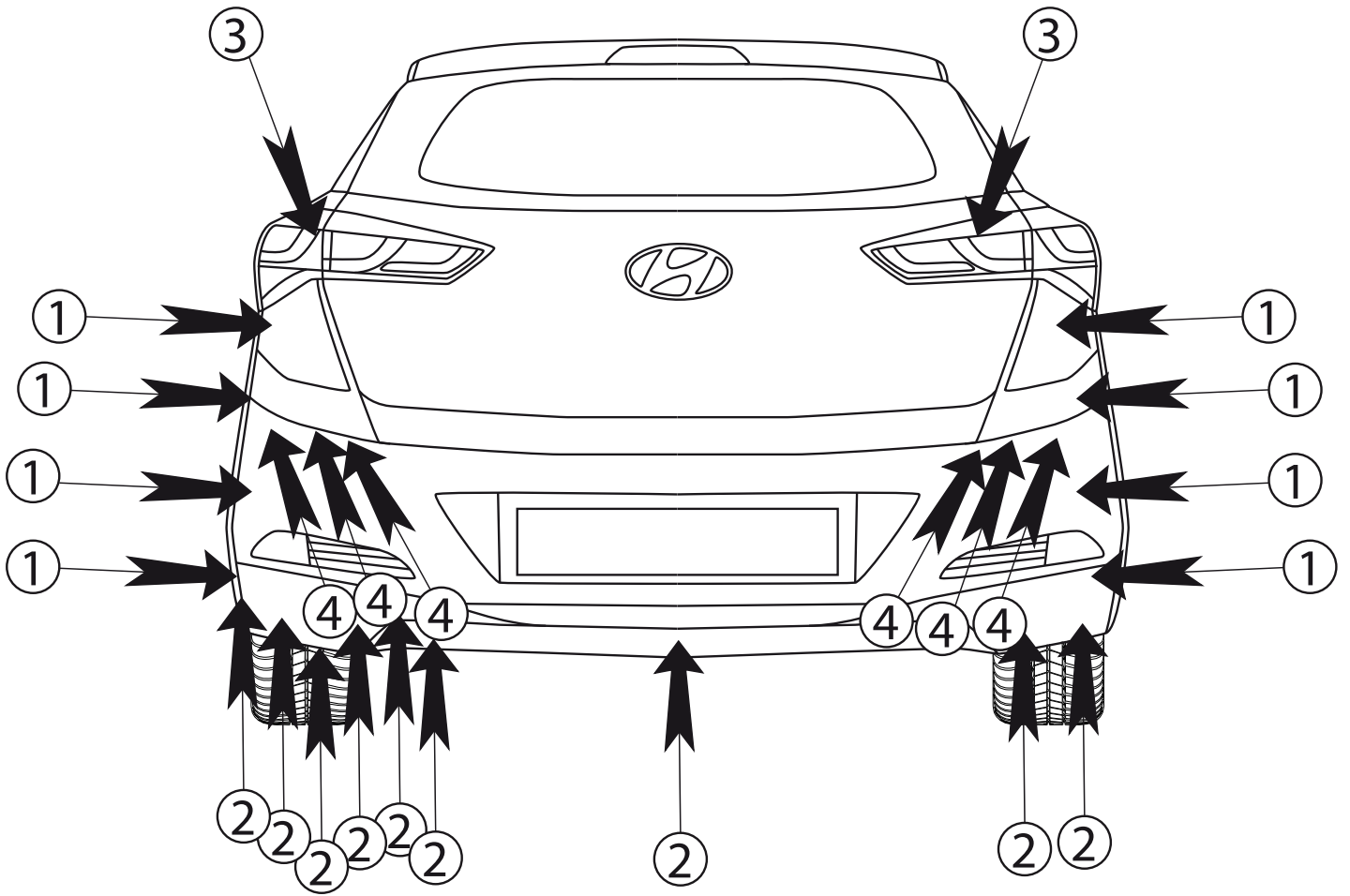

KIA RIO [2017+]

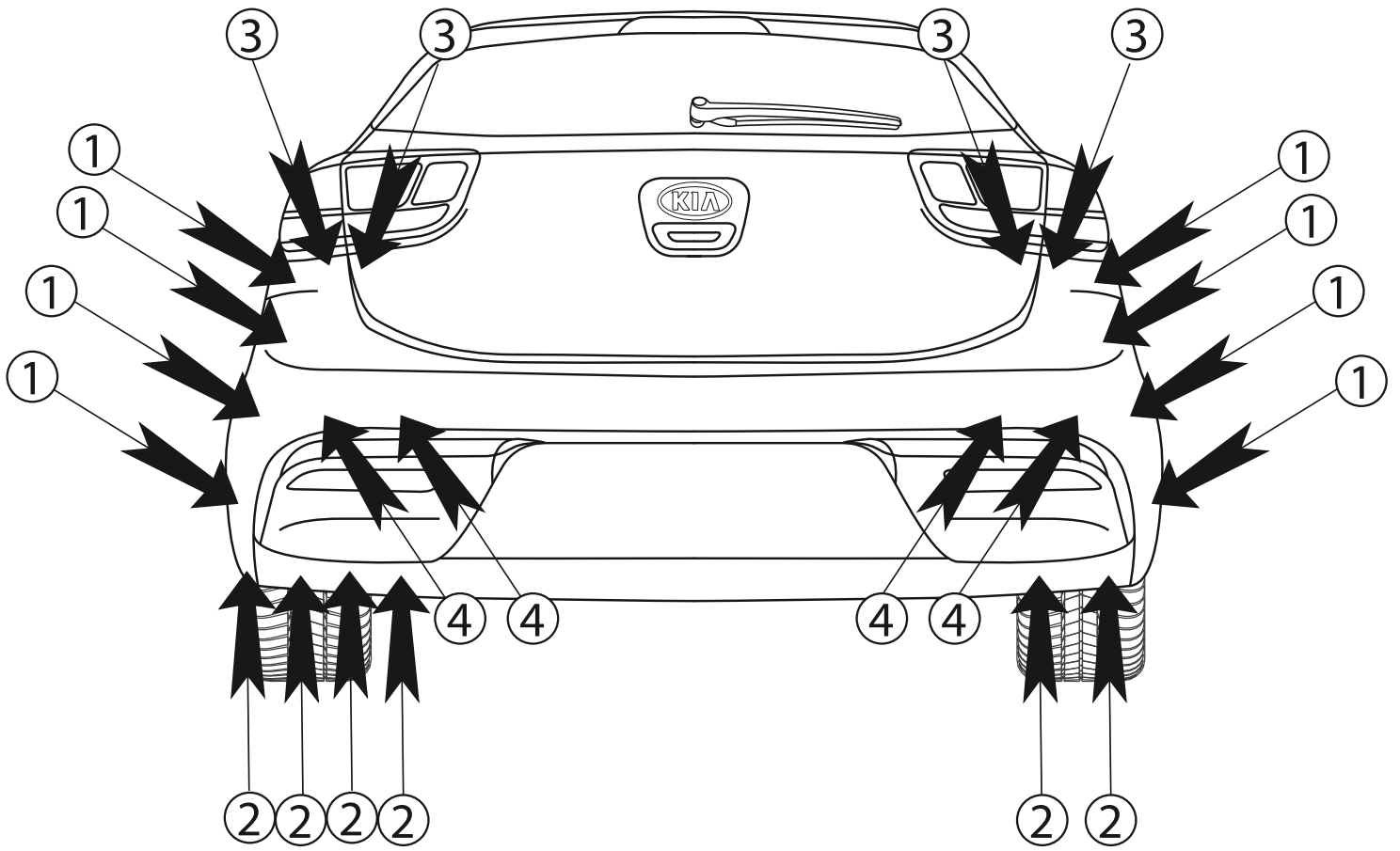

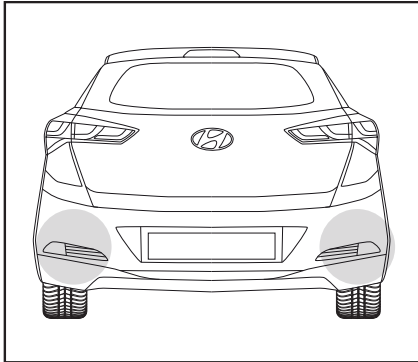

HYUNDAI i20 [2015-2019]

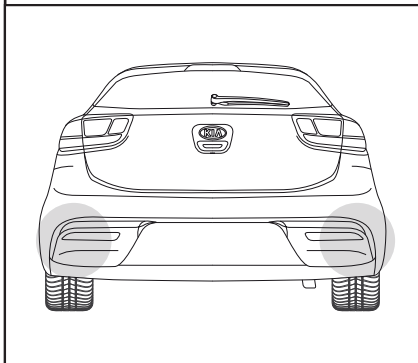

KIA RIO [2017+]

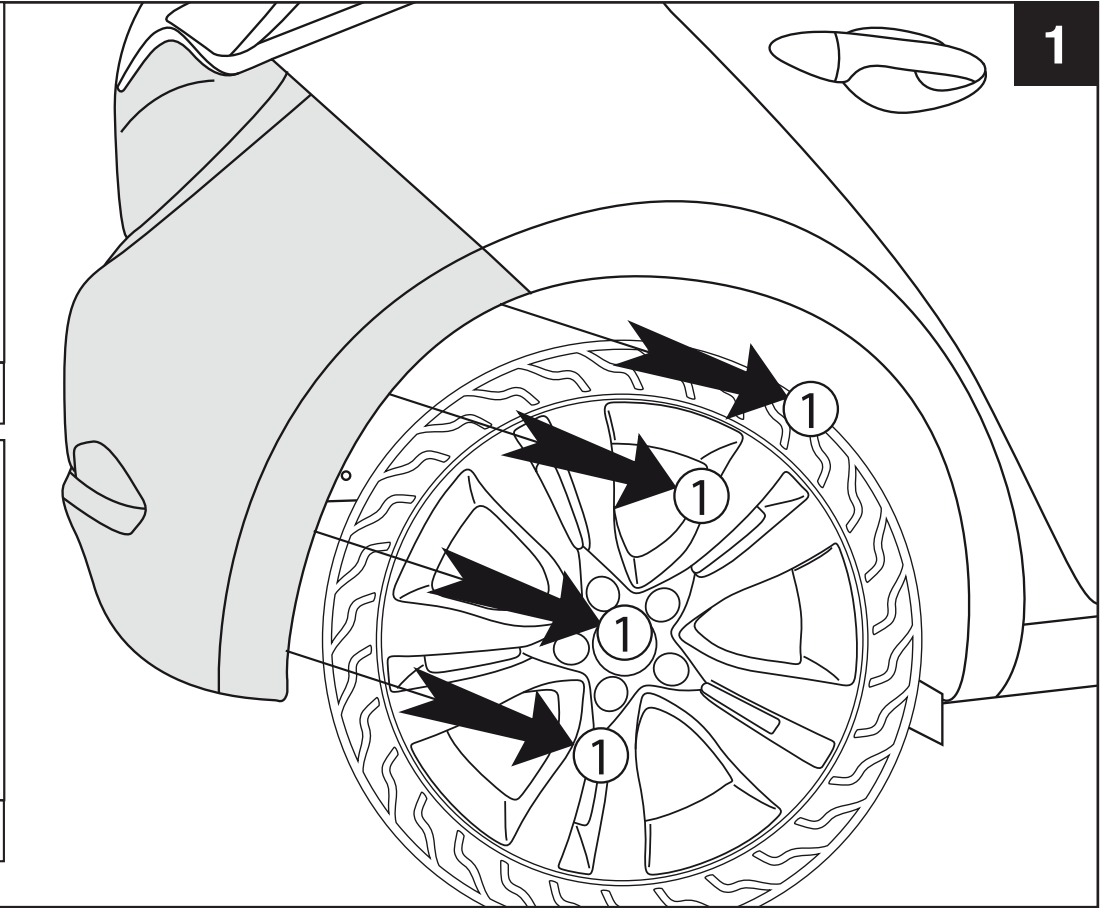

1

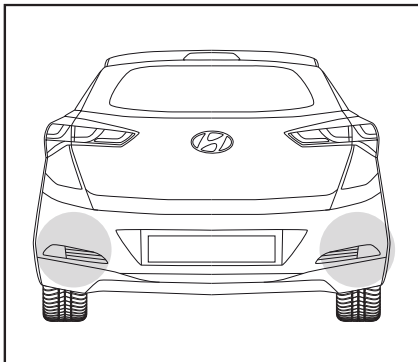

HYUNDAI i20 [2015-2019]

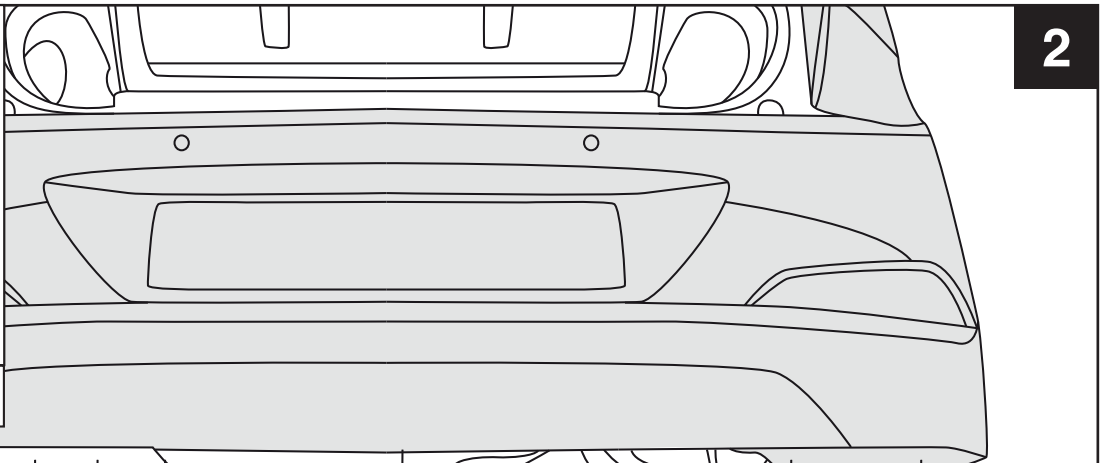

2

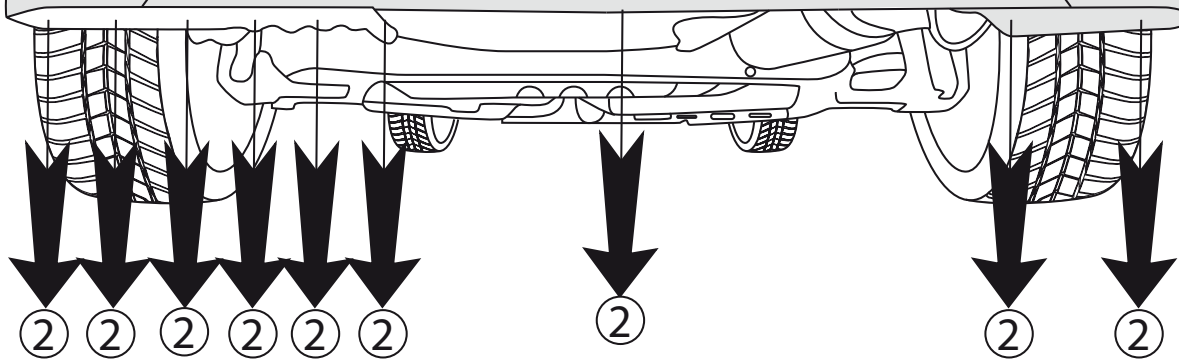

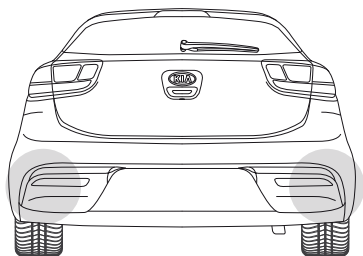
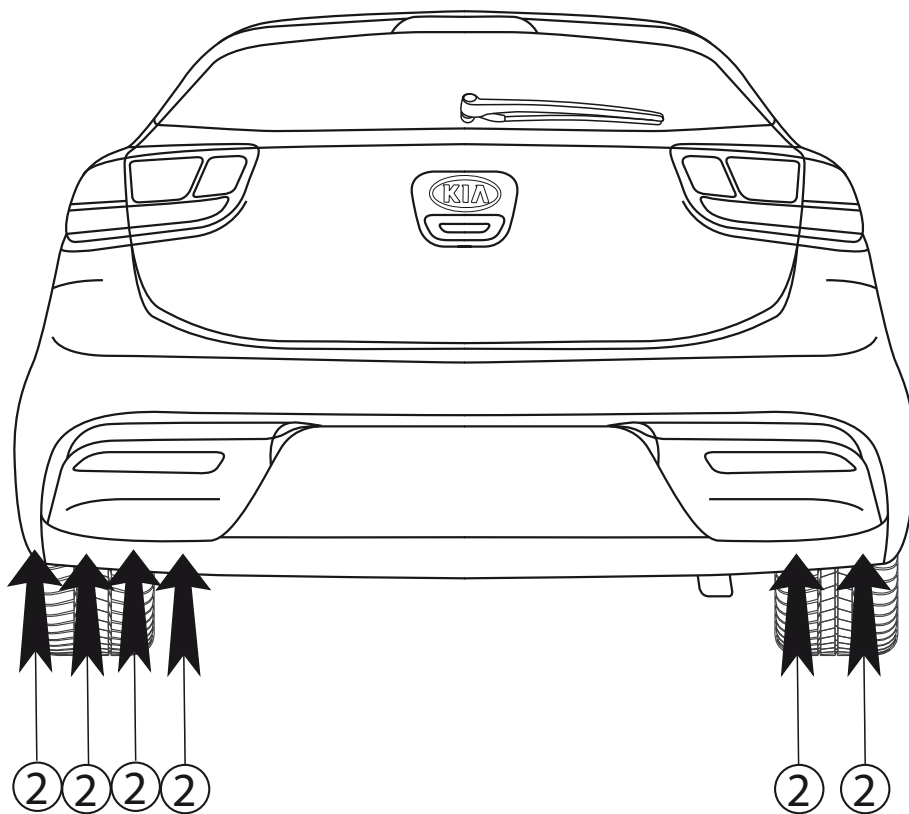

KIA RIO [2017+]

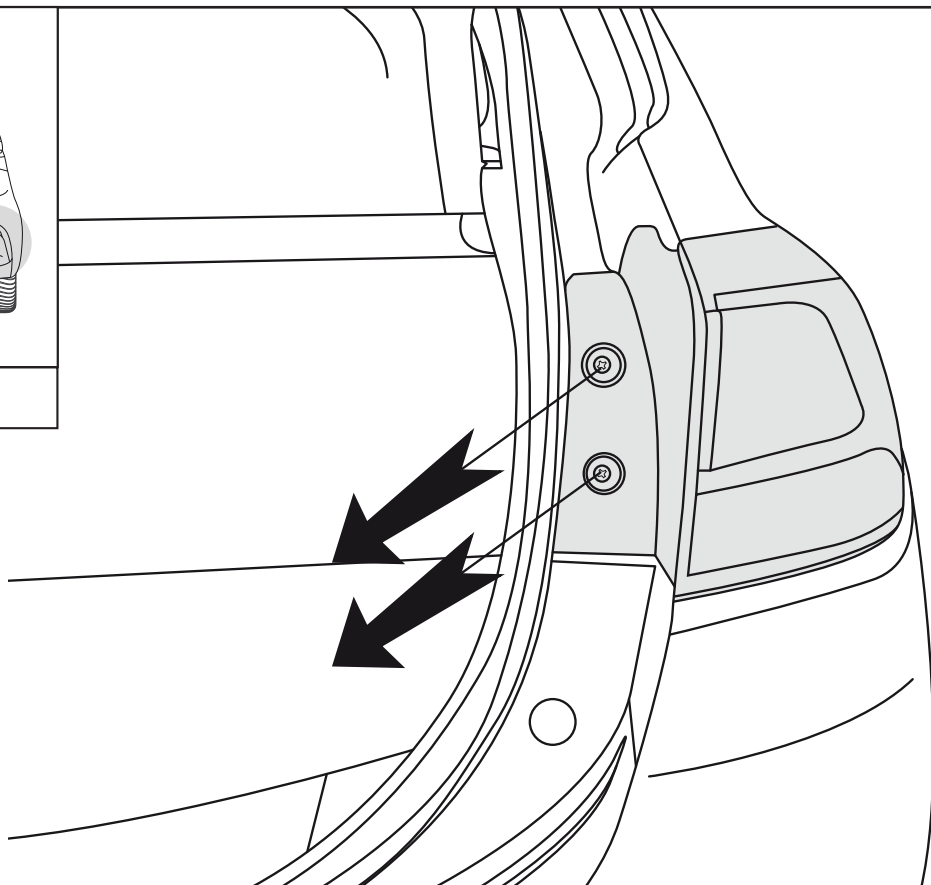

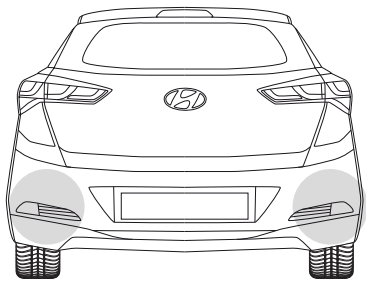

HYUNDAI i20 [2015-2019]

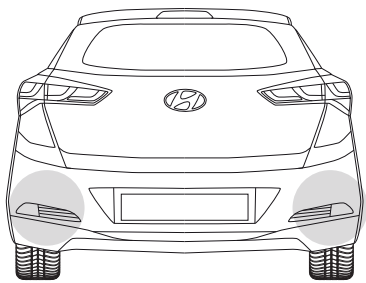
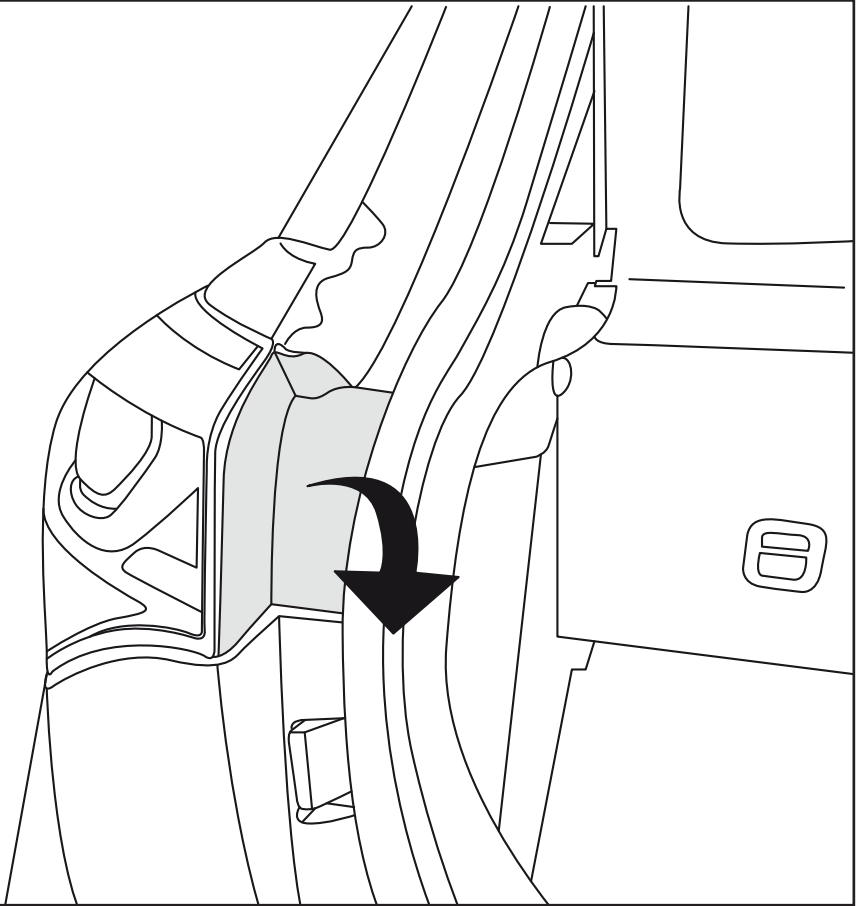

HYUNDAI i20 [2015-2019]

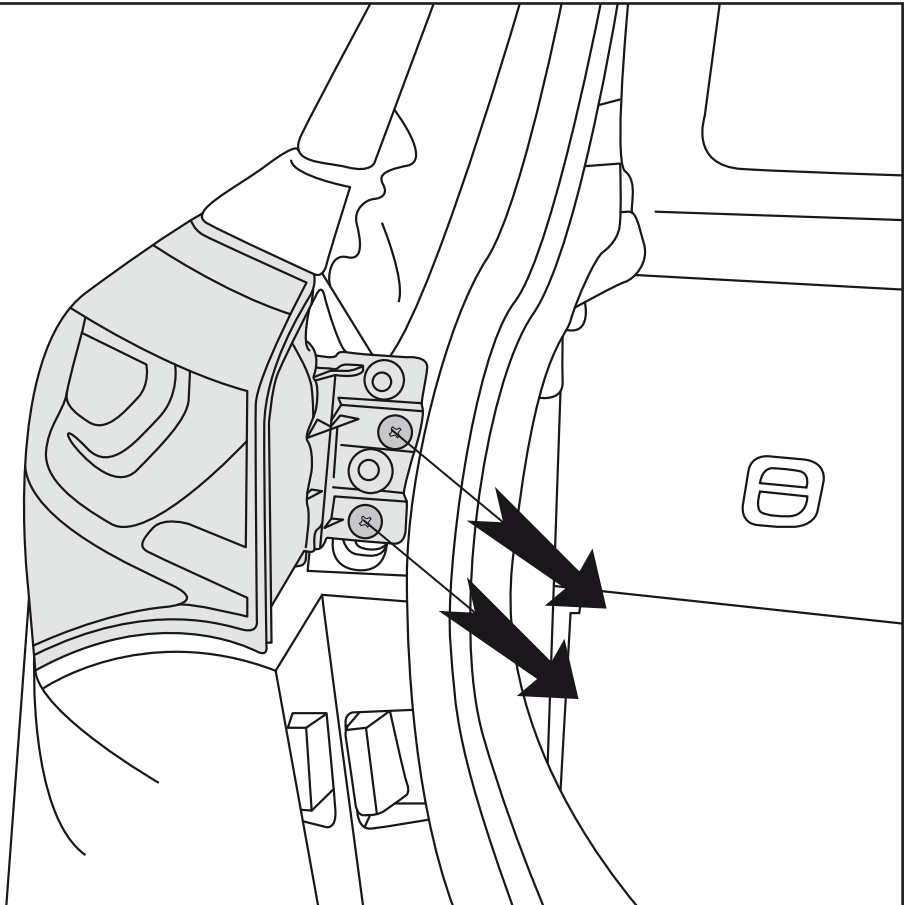

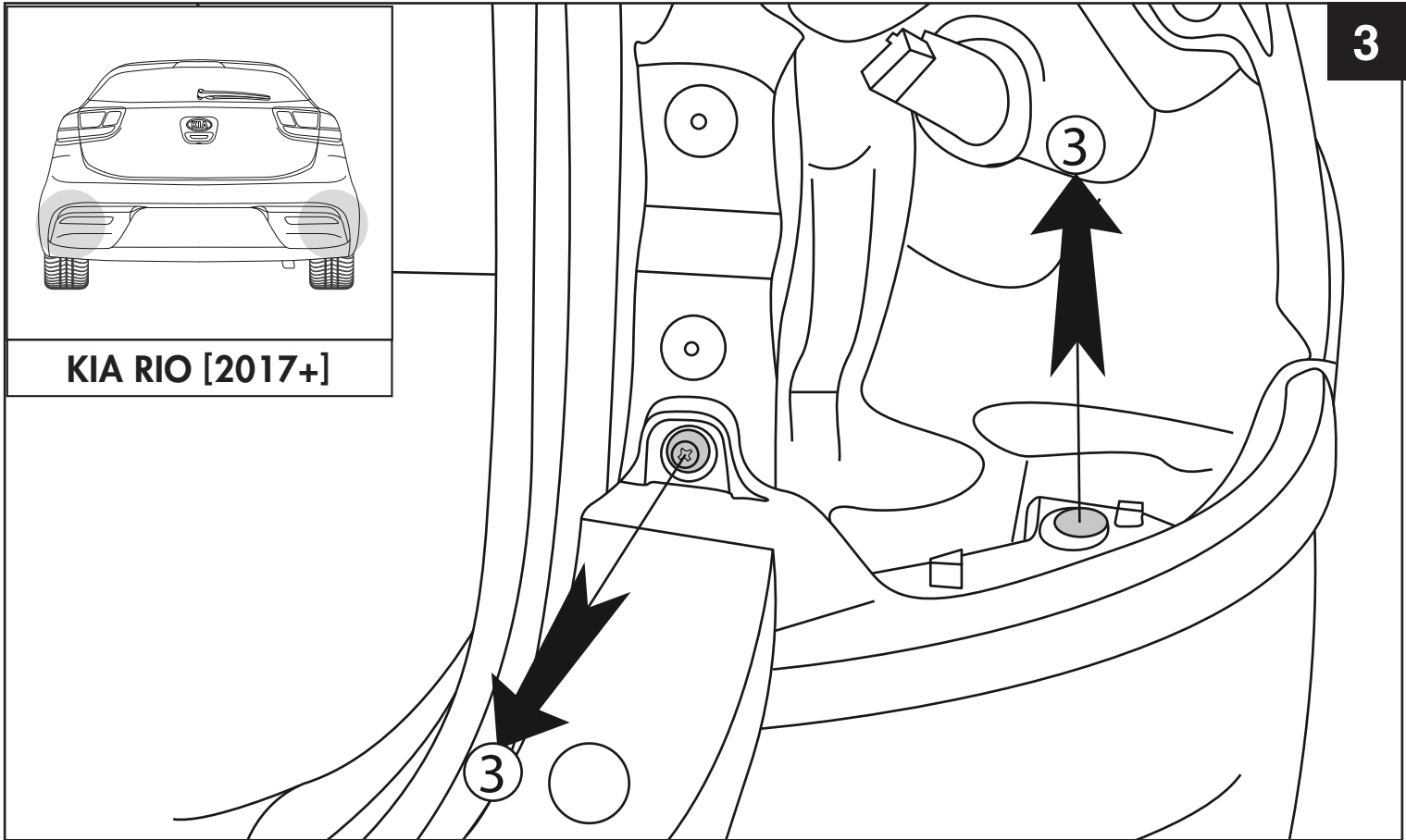
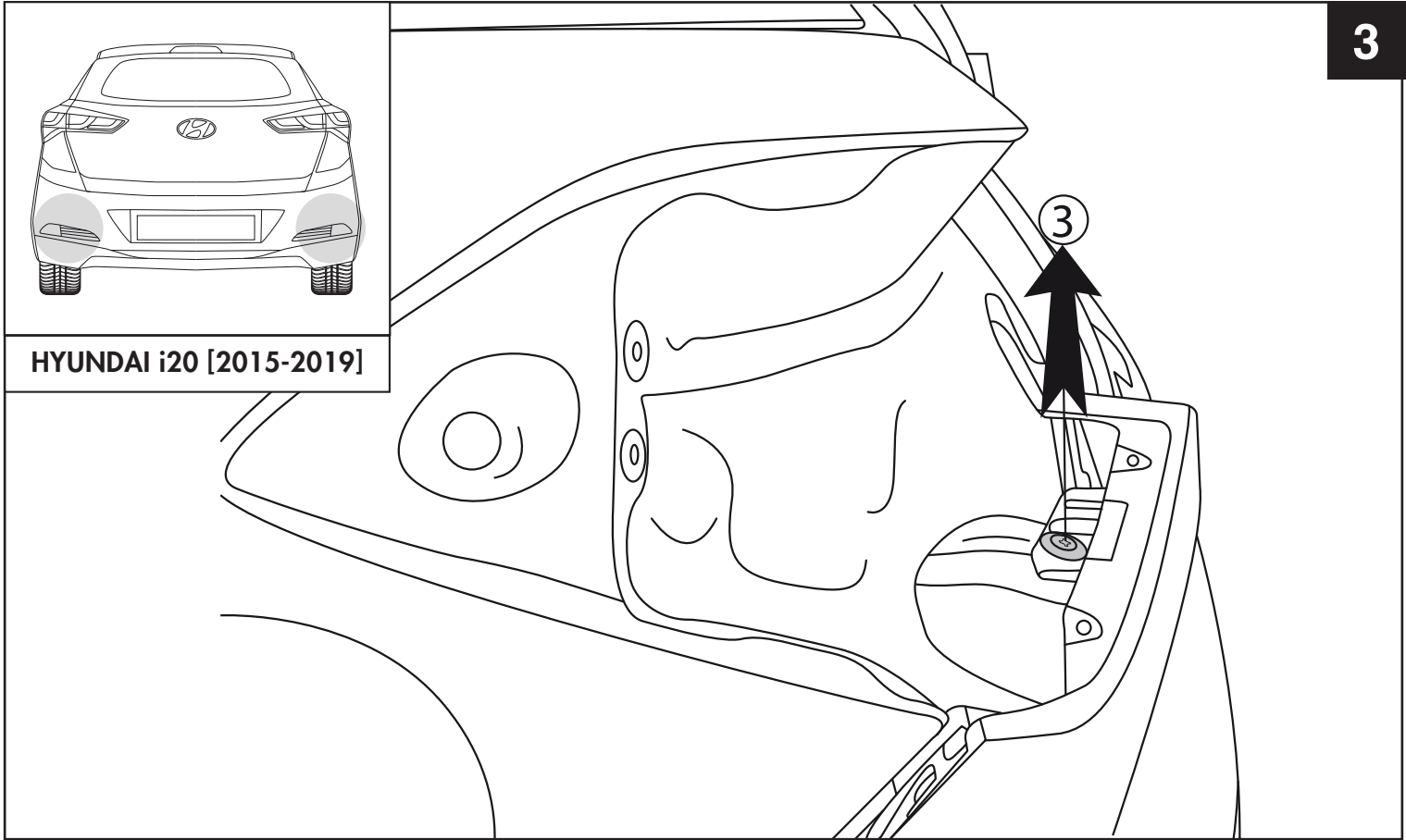

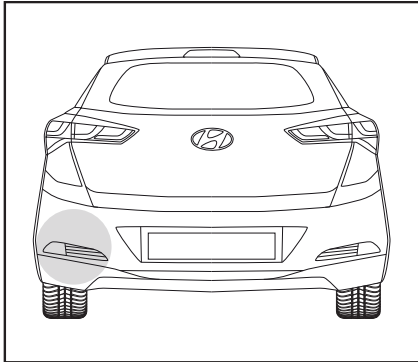

HYUNDAI i20 [2015-2019]

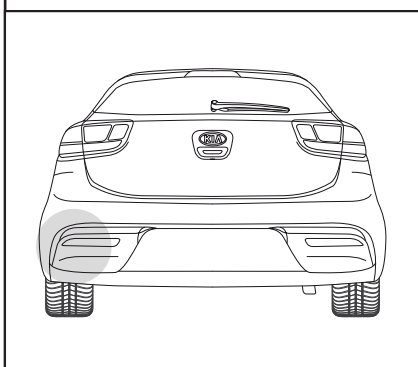

KIA RIO [2017+]

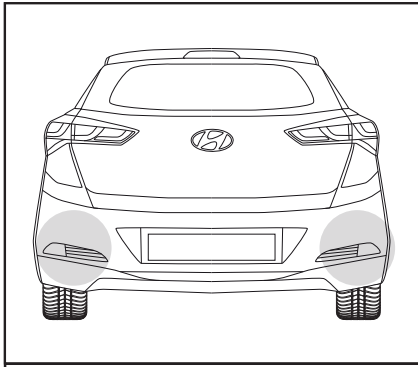
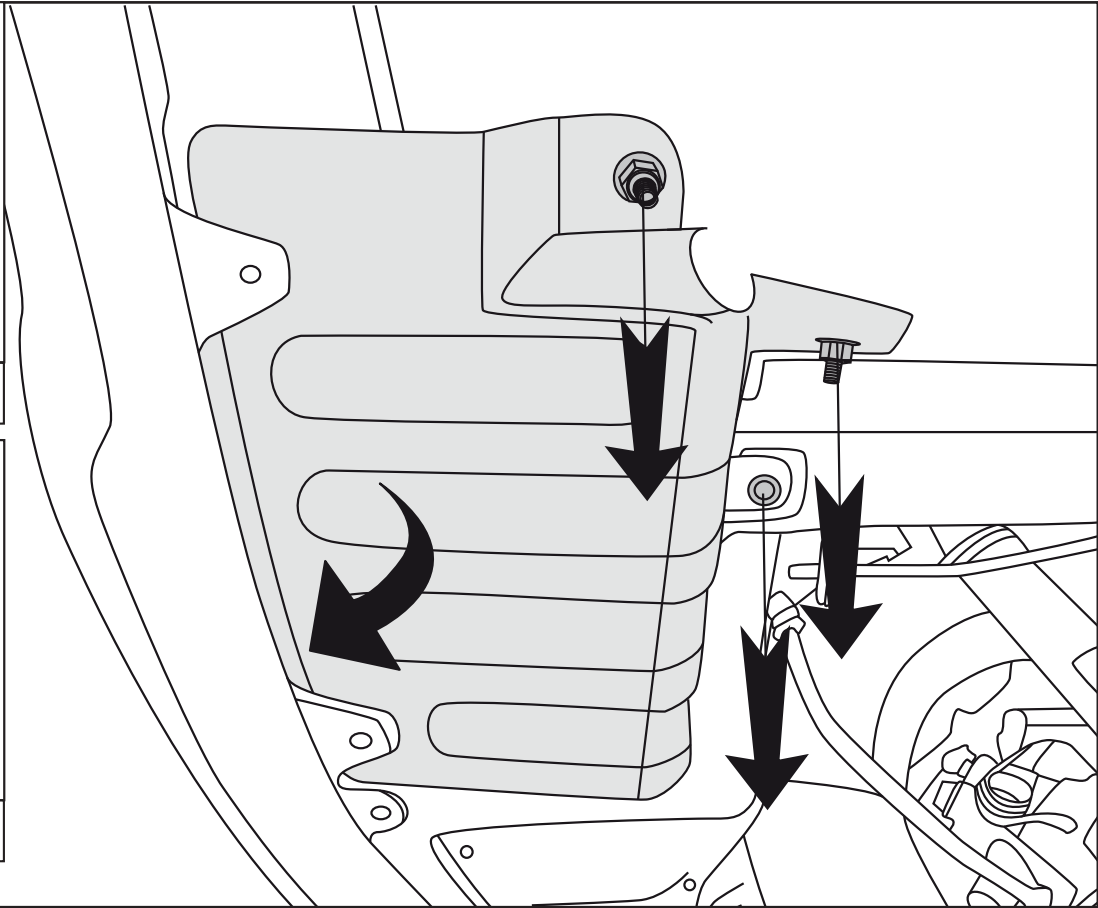

HYUNDAI i20 [2015-2019]

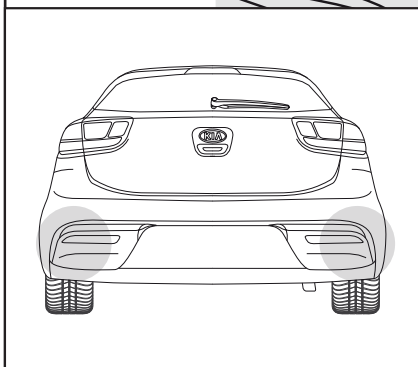

KIA RIO [2017+]

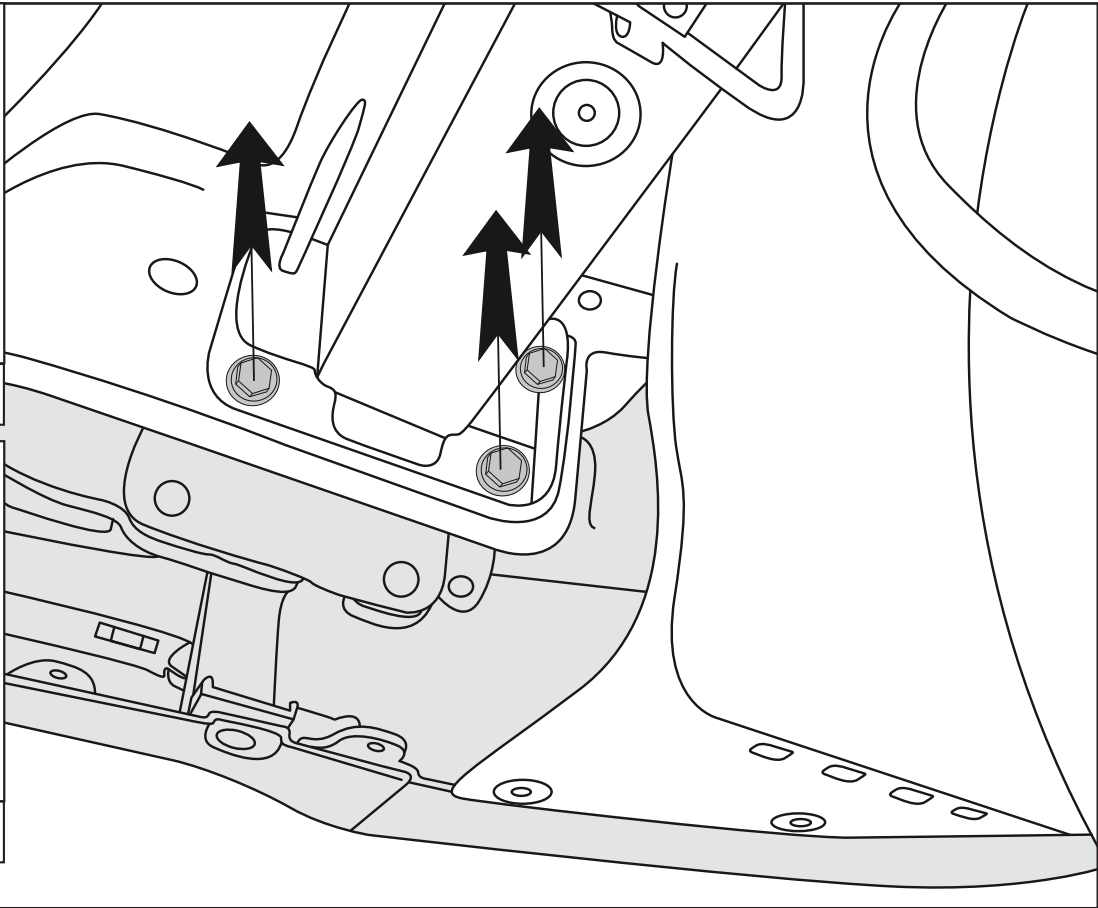

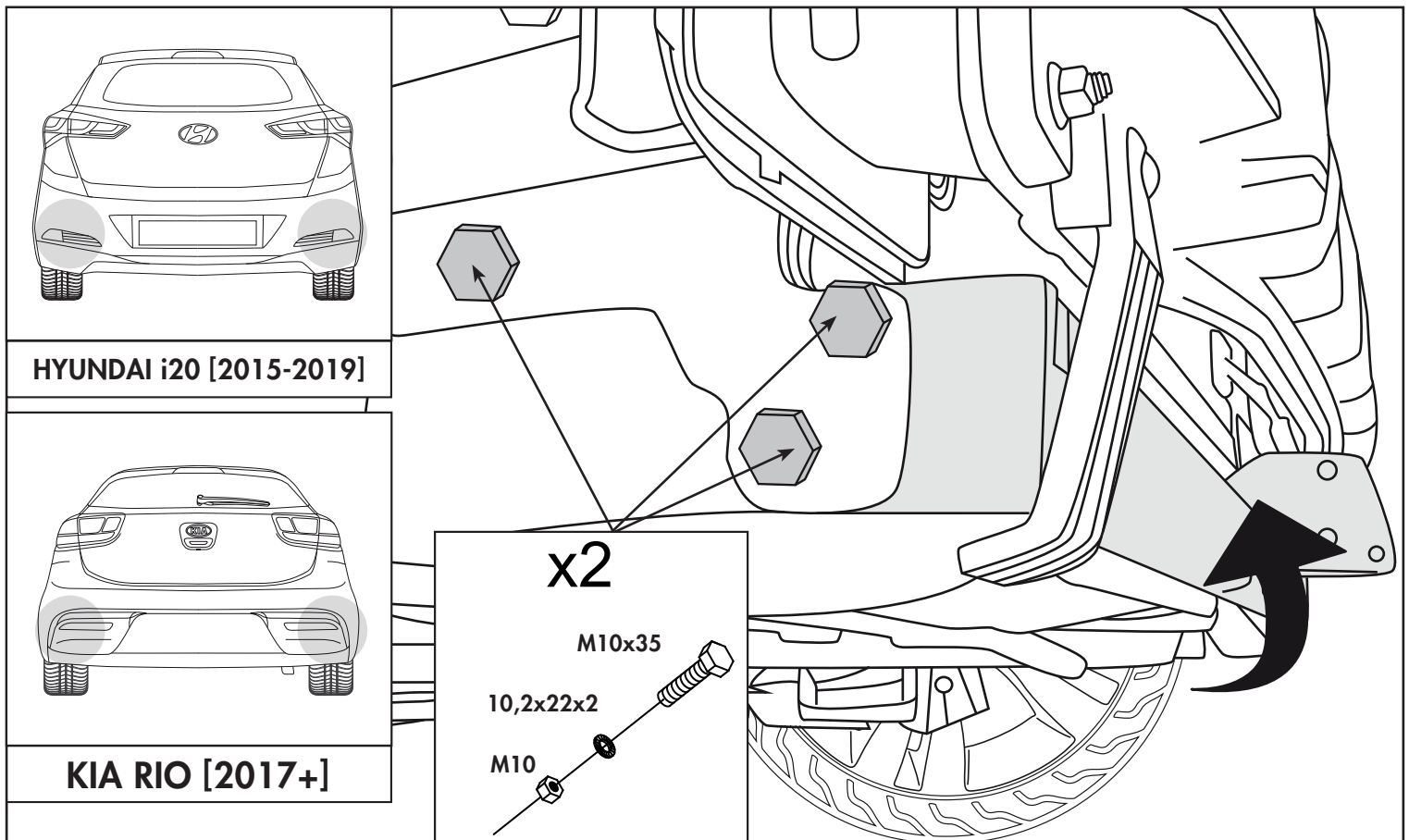
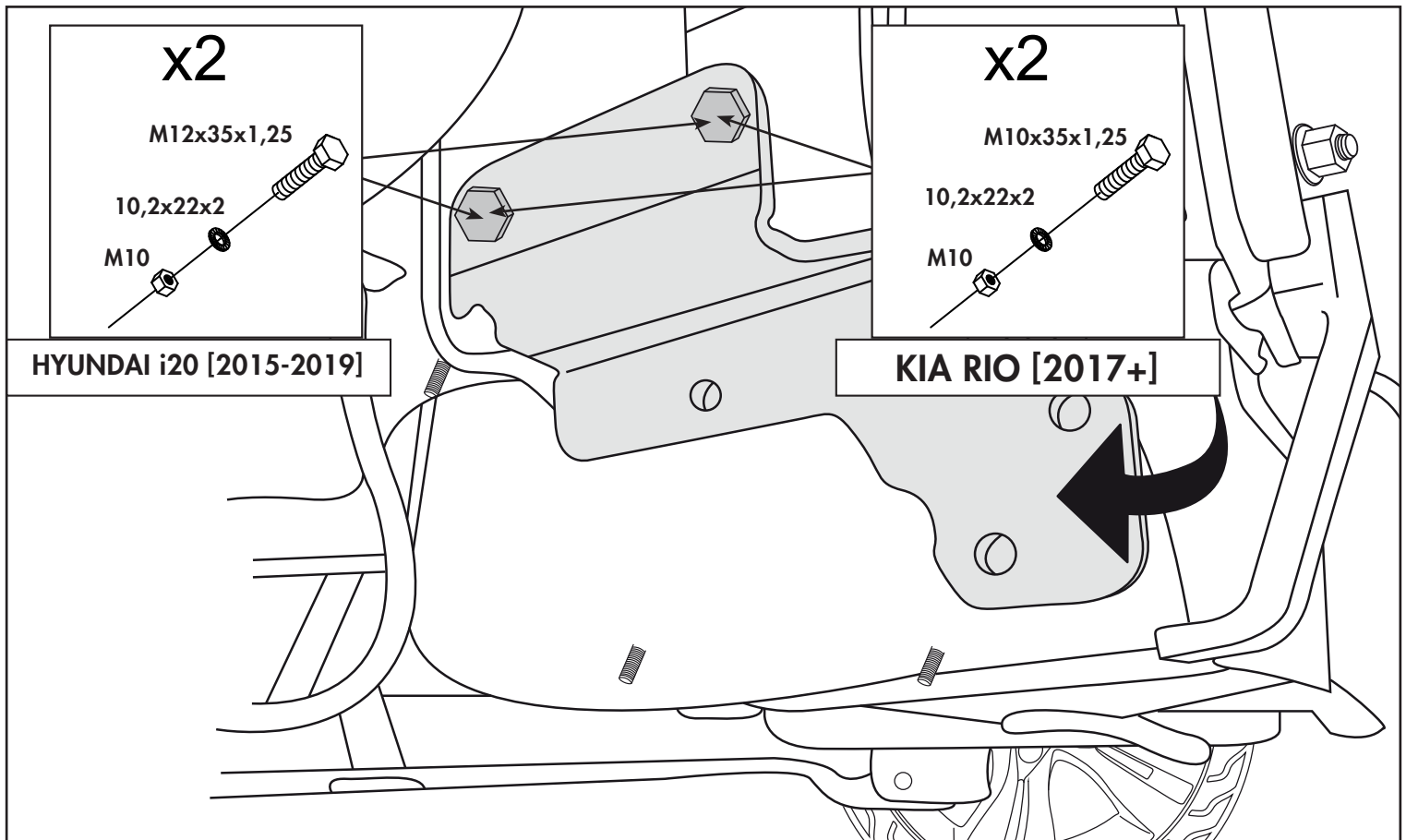



**KIA RIO [2017+]
45025/F**

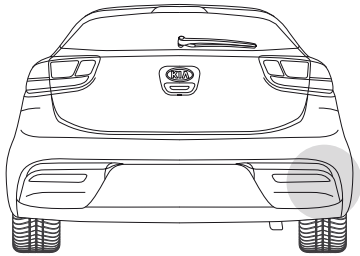
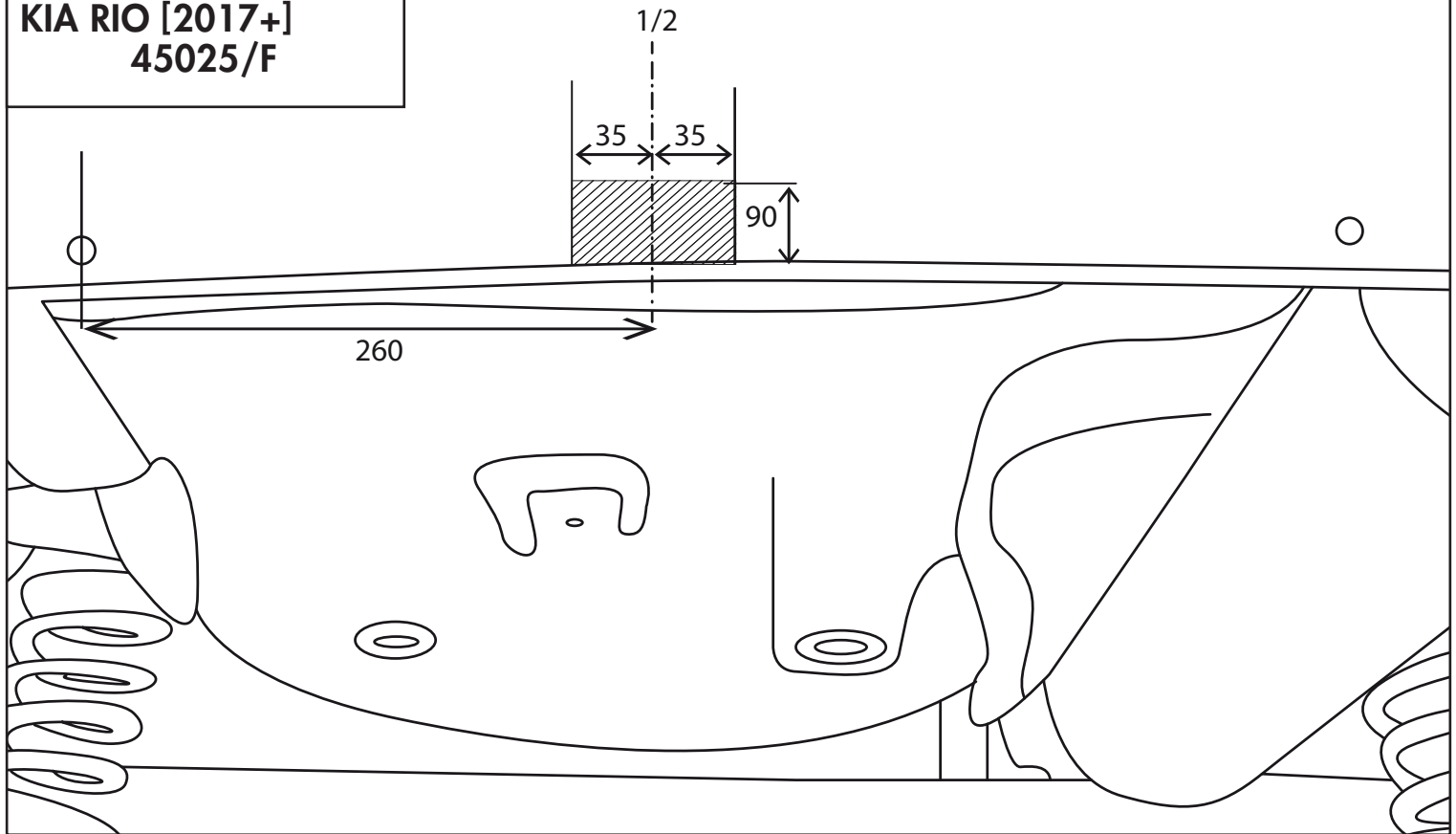

KIA RIO [2017+]

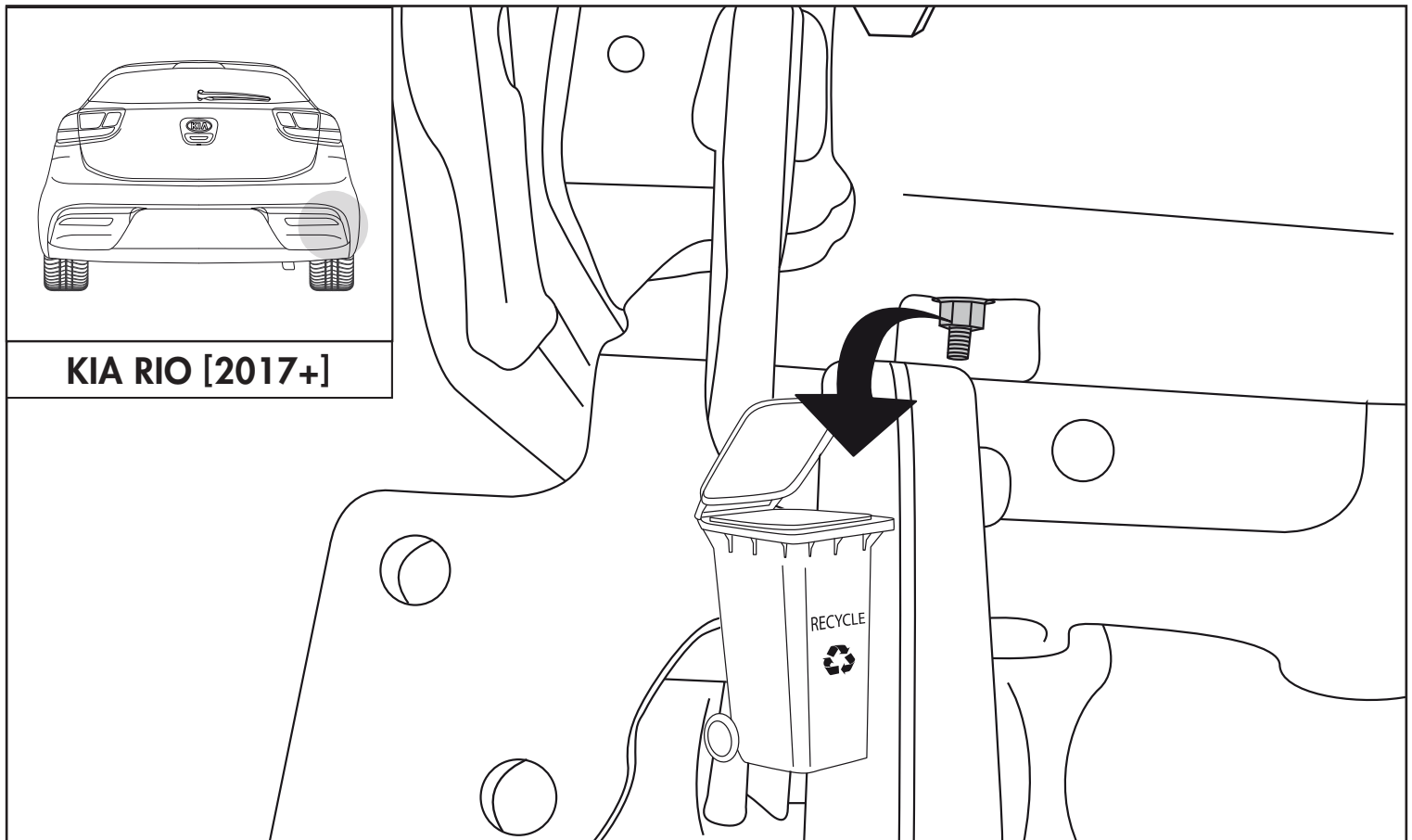

LA GARANTIE

En cas d'utilisation de l'attelage, les instructions du constructeur du véhicule concernant le poids tractable maximum autorisé ainsi que la charge verticale maximum sur la boule doivent être respectées. Ces instructions se trouvent dans les documents de bord du véhicule et dans le certificat WVTA. Merci de vous rapprocher du concessionnaire de la marque de votre véhicule afin de connaître son poids maximum tractable. Il est interdit de dépasser les charges données dans les documents qui accompagnent l'attelage.

Avant de tracter, raccorder la connexion électrique, et la chaîne de sécurité qui permet l'arrêt automatique de la remorque en cas de rupture de l'attelage.

Dans un cas extrême, la surcharge de l'attelage peut entraîner sa rupture et la perte du véhicule tracté (remorque, caravane, porte vélo...). La conséquence peut être une blessure grave ou mortelle pour les occupants du véhicule tracteur et/ou les piétons et usagés de la route.

Bosal décline toute responsabilité pour les défauts éventuels du produit causés par une mauvaise utilisation (y compris la surcharge) occasionnée par l'utilisateur.

Il est interdit d'utiliser des points de fixation autres que ceux mentionnés dans la notice de pose de l'attelage.

Avant la commercialisation, tous nos attelages sont soumis à un test dynamique de longévité (2 millions de cycles).

Bosal décline toute responsabilité en cas d'adjonction de stabilisateur ou répartiteur de charge entre le véhicule tracteur et tracté.

La garantie ne s'applique qu'aux produits neufs, Bosal n'engagera pas sa responsabilité sur un produit d'occasion.

RADARS DE REcul

Il est possible que la rotule soit détectée, dans ce cas, il est nécessaire de la déposer lorsqu'elle n'est pas utilisée.

Bosal recommande fortement le montage de l'attelage démontable sans outil lorsque le véhicule est équipé de radars de recul.