



**VOLKSWAGEN SHARAN**  
verificare valore D

[2010+]

**SEAT ALHAMBRA**  
verificare valore D

[2010+]









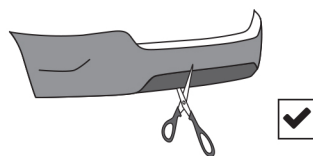

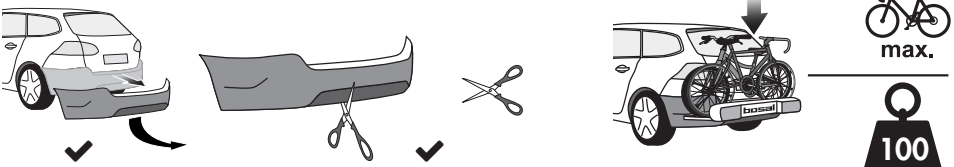







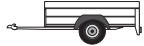

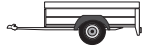
---

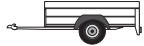
**Part Number:** 552-021

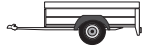
**Type Number:** 552-021

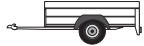
---

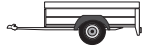

												
												
												
	<p>e3 00 - 7637 01 (DIR. 94/20/CE)</p>											
	<table style="width: 100%; border: none;"> <tr> <td style="width: 50%;">M6 = 10</td> <td style="width: 50%;">M12 = 85</td> </tr> <tr> <td>M8 = 25</td> <td>M14 = 135</td> </tr> <tr> <td>M10 = 55</td> <td>M16 = 200</td> </tr> </table>	M6 = 10	M12 = 85	M8 = 25	M14 = 135	M10 = 55	M16 = 200					
M6 = 10	M12 = 85											
M8 = 25	M14 = 135											
M10 = 55	M16 = 200											
	<table style="width: 100%; border: none;"> <tr> <td style="text-align: center;">MAX ↓ kg</td> <td style="text-align: center;">MAX ↓ kg</td> <td rowspan="2" style="vertical-align: middle; padding-left: 20px;"><math>\times 0,0098' \leq 12</math></td> </tr> <tr> <td style="text-align: center;">  </td> <td style="text-align: center;">  </td> </tr> <tr> <td style="text-align: center;">MAX ↓ kg</td> <td style="text-align: center;">MAX ↓ kg</td> <td></td> </tr> <tr> <td style="text-align: center;">  </td> <td style="text-align: center;">  </td> <td></td> </tr> </table>	MAX ↓ kg	MAX ↓ kg	$\times 0,0098' \leq 12$			MAX ↓ kg	MAX ↓ kg				
MAX ↓ kg	MAX ↓ kg	$\times 0,0098' \leq 12$										
												
MAX ↓ kg	MAX ↓ kg											
												
	<p style="text-align: center; font-size: 24px;">1H00</p>											

4

F			
<b>1</b>	2x	M12x70 (8.8)	
<b>2</b>	2x	M12 (8.8)	
(F59H)			

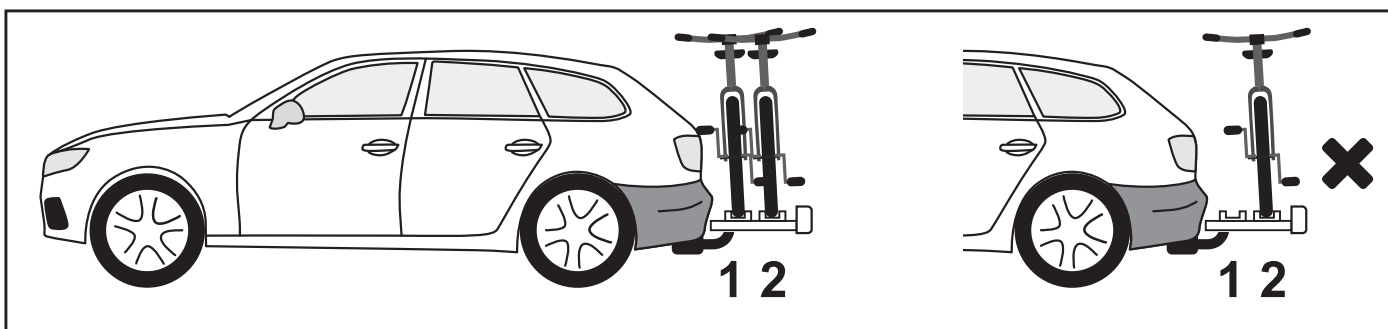
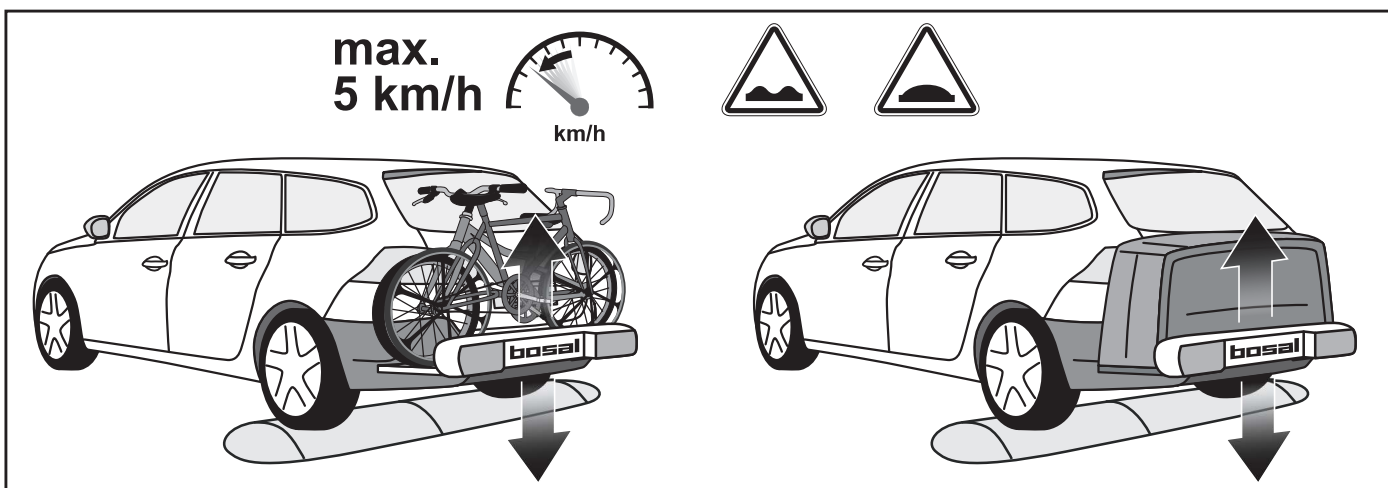
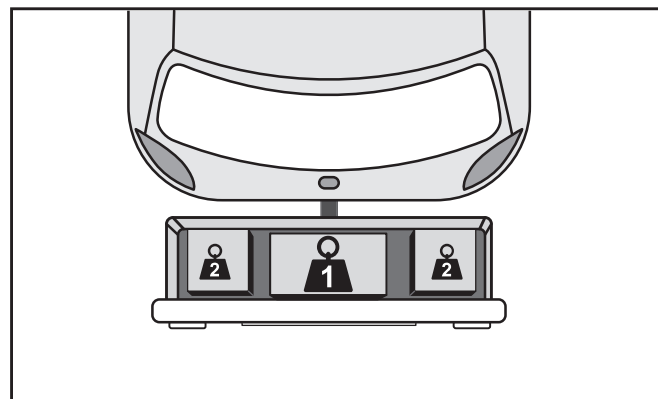
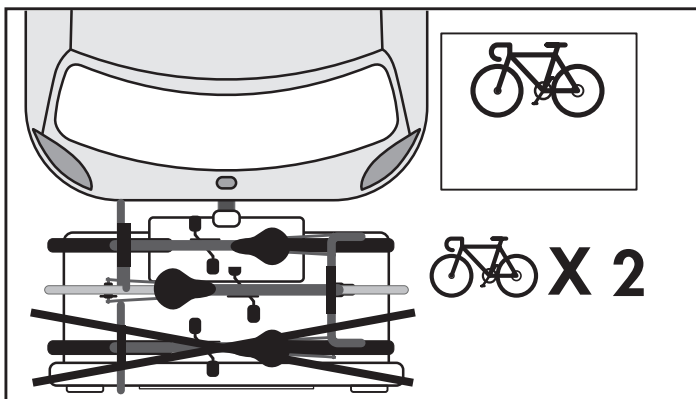
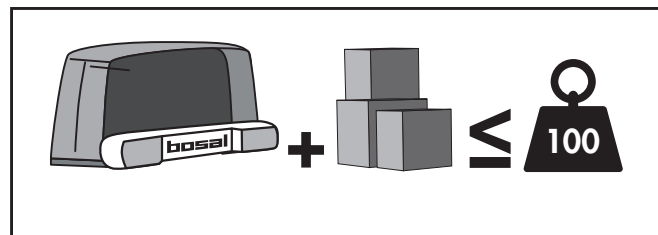
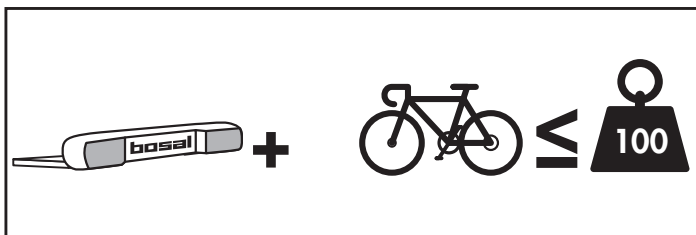
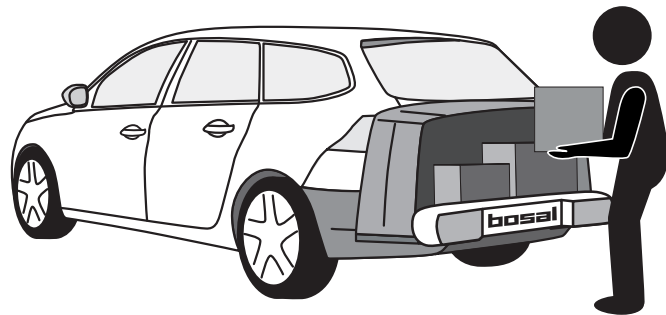
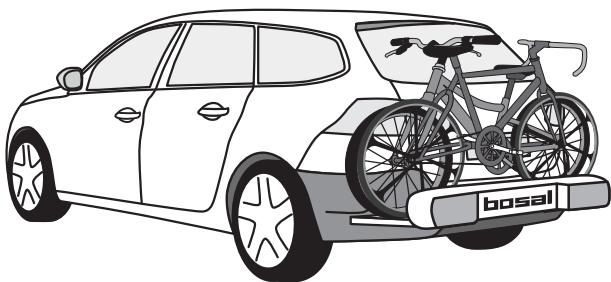

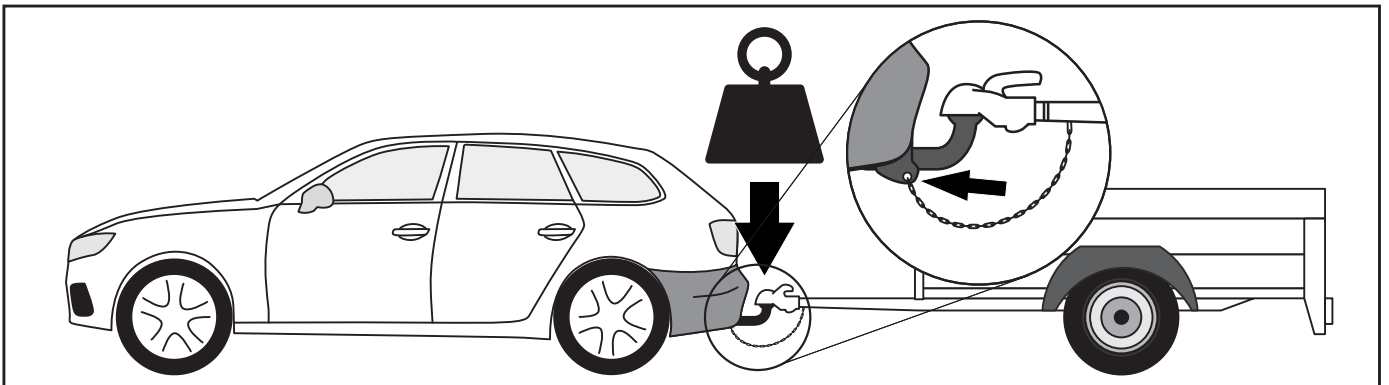
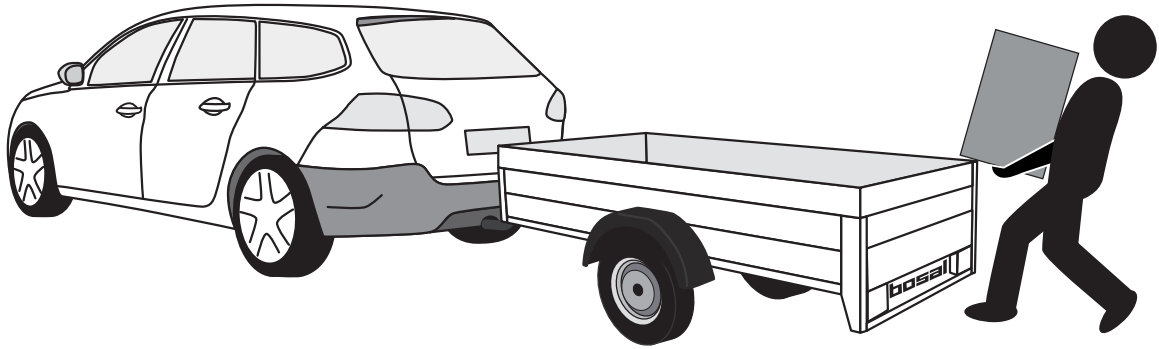

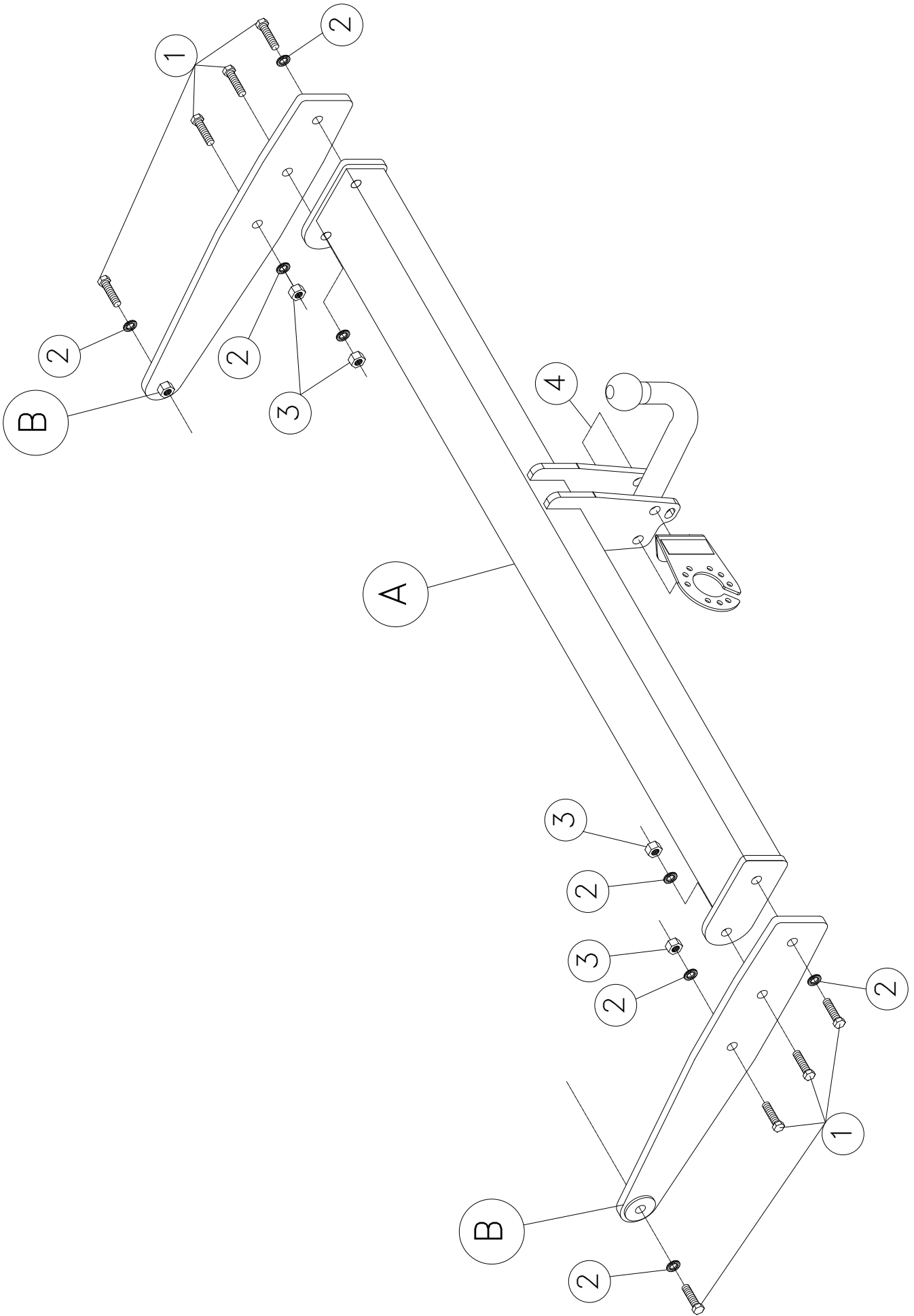

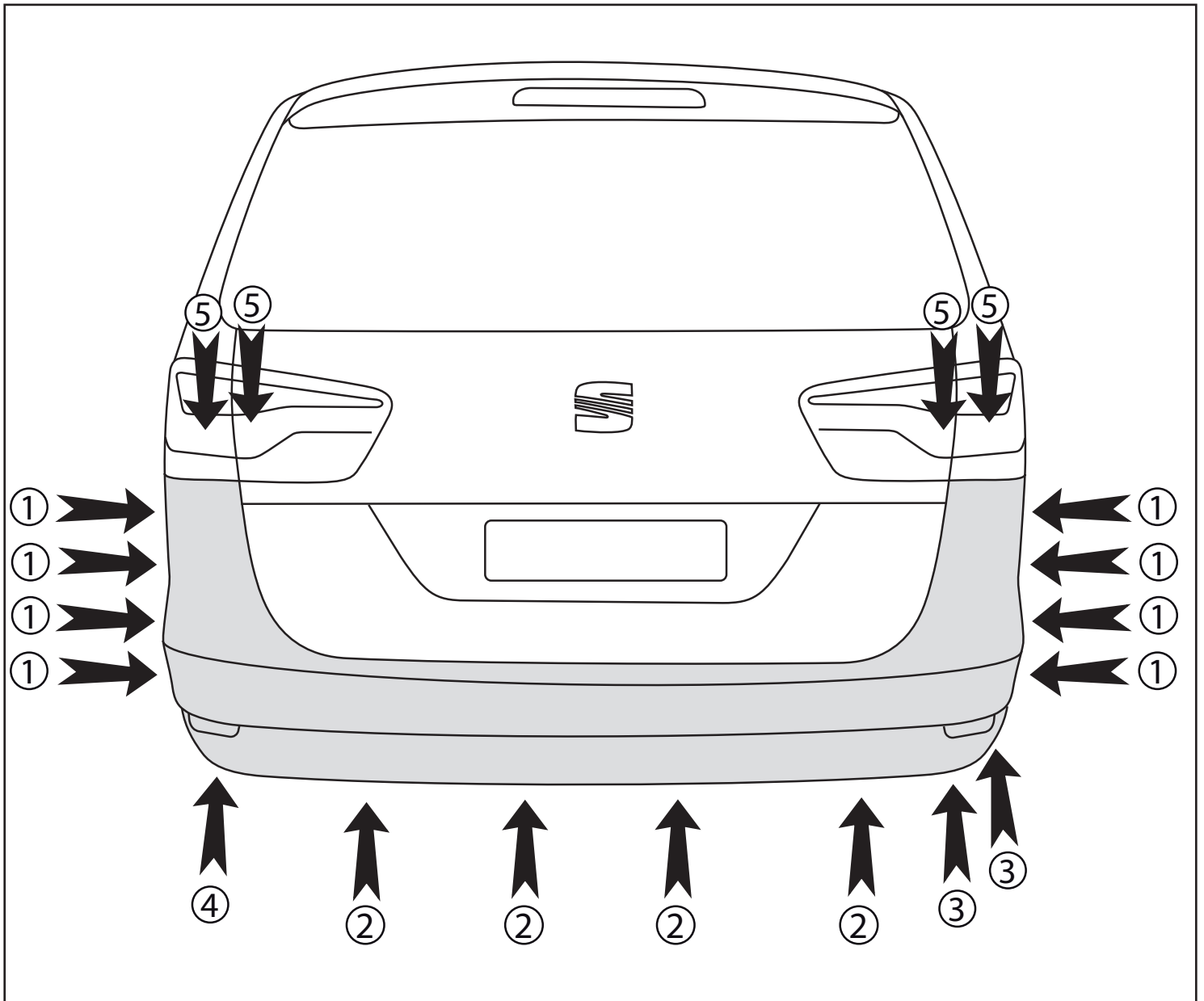

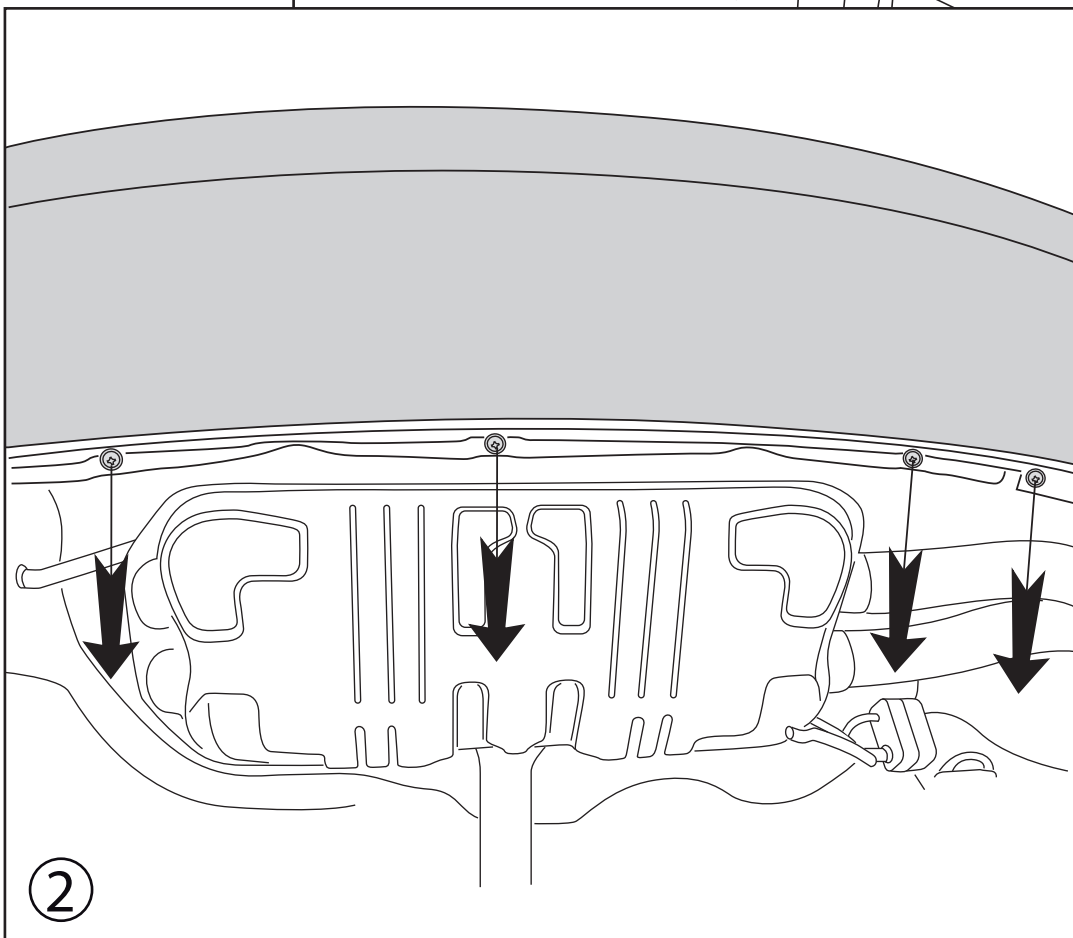
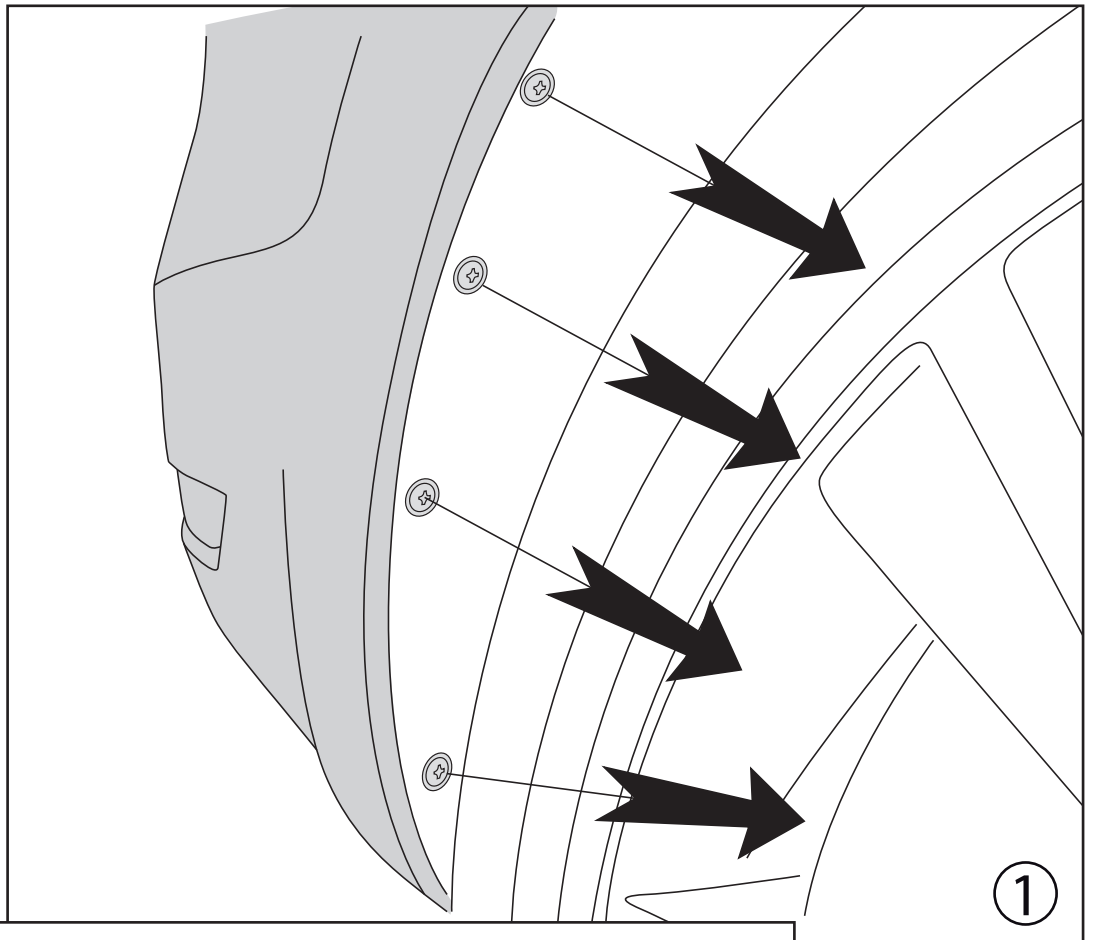

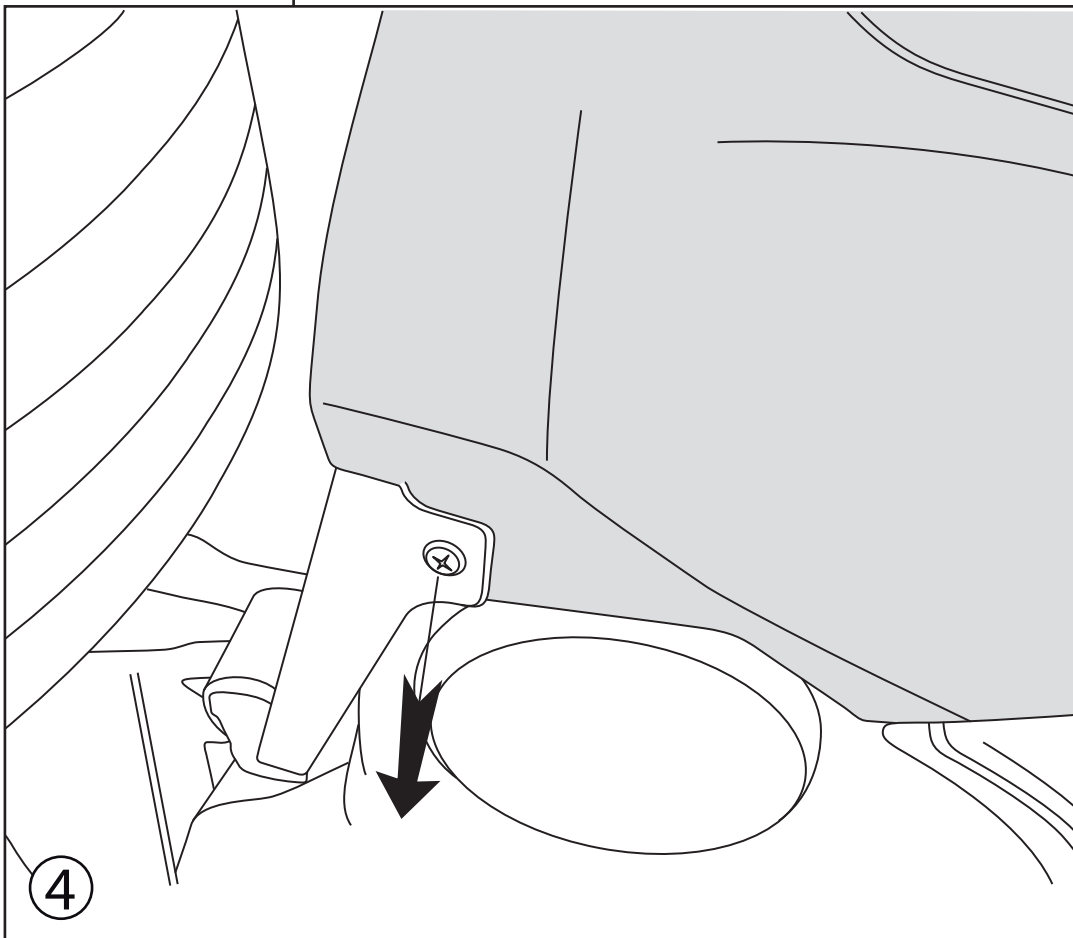
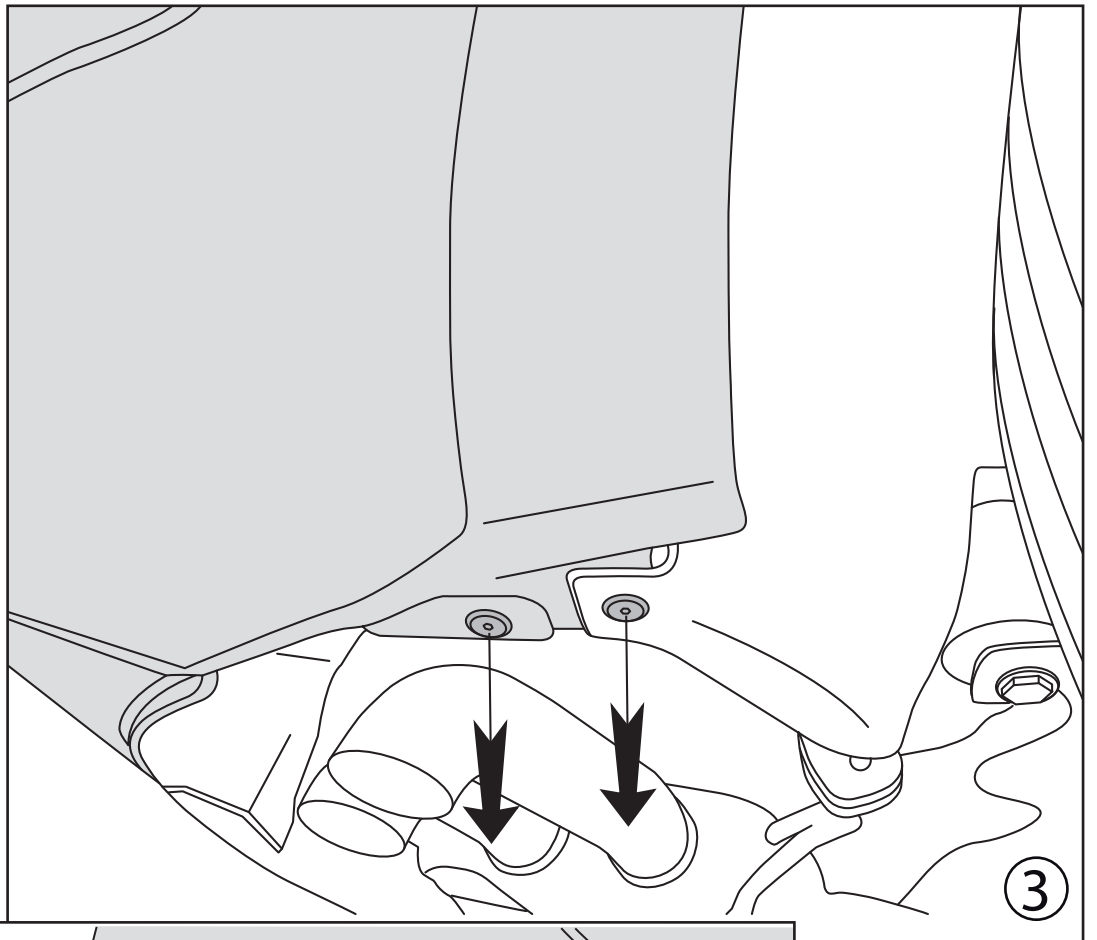

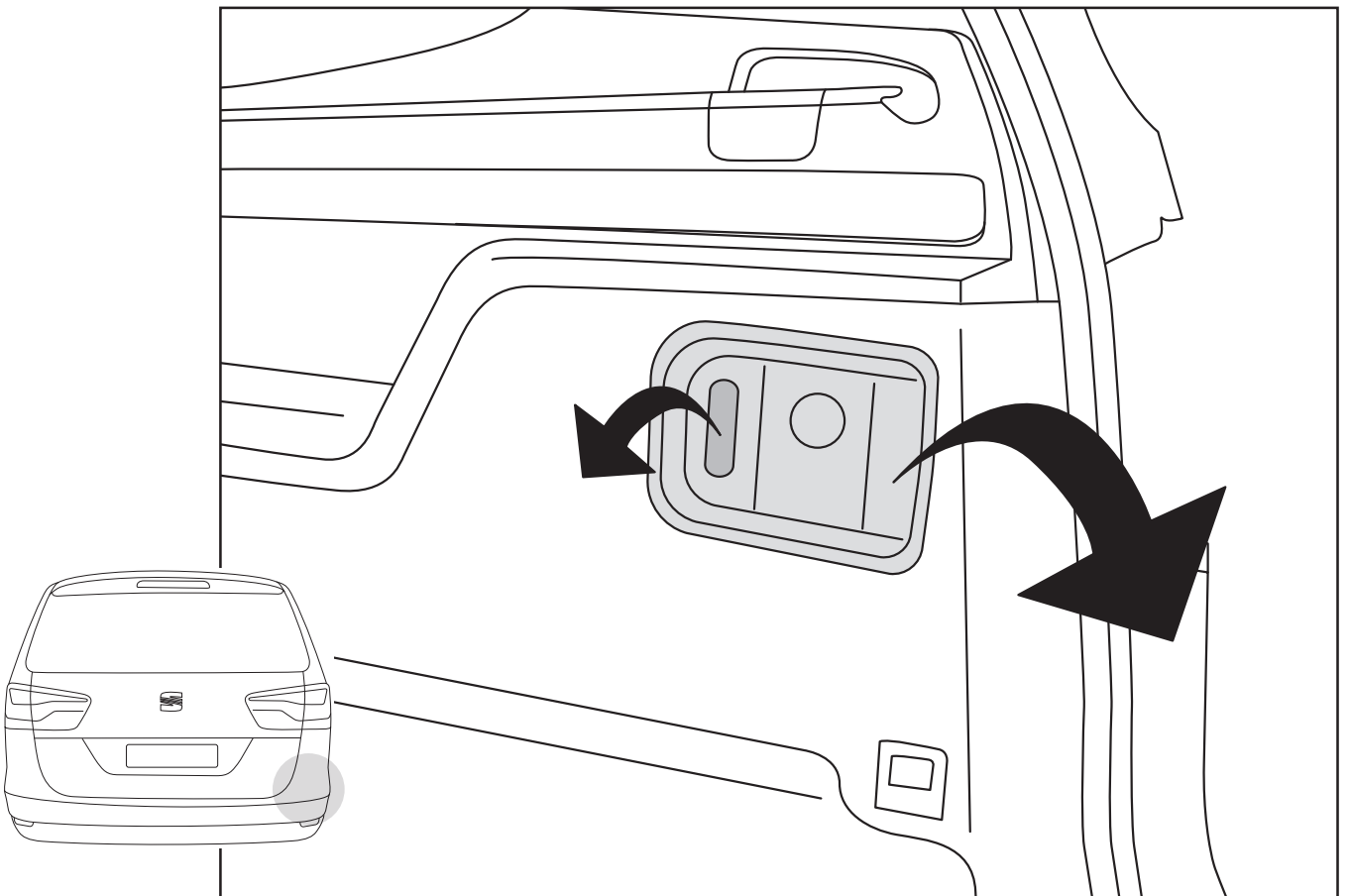
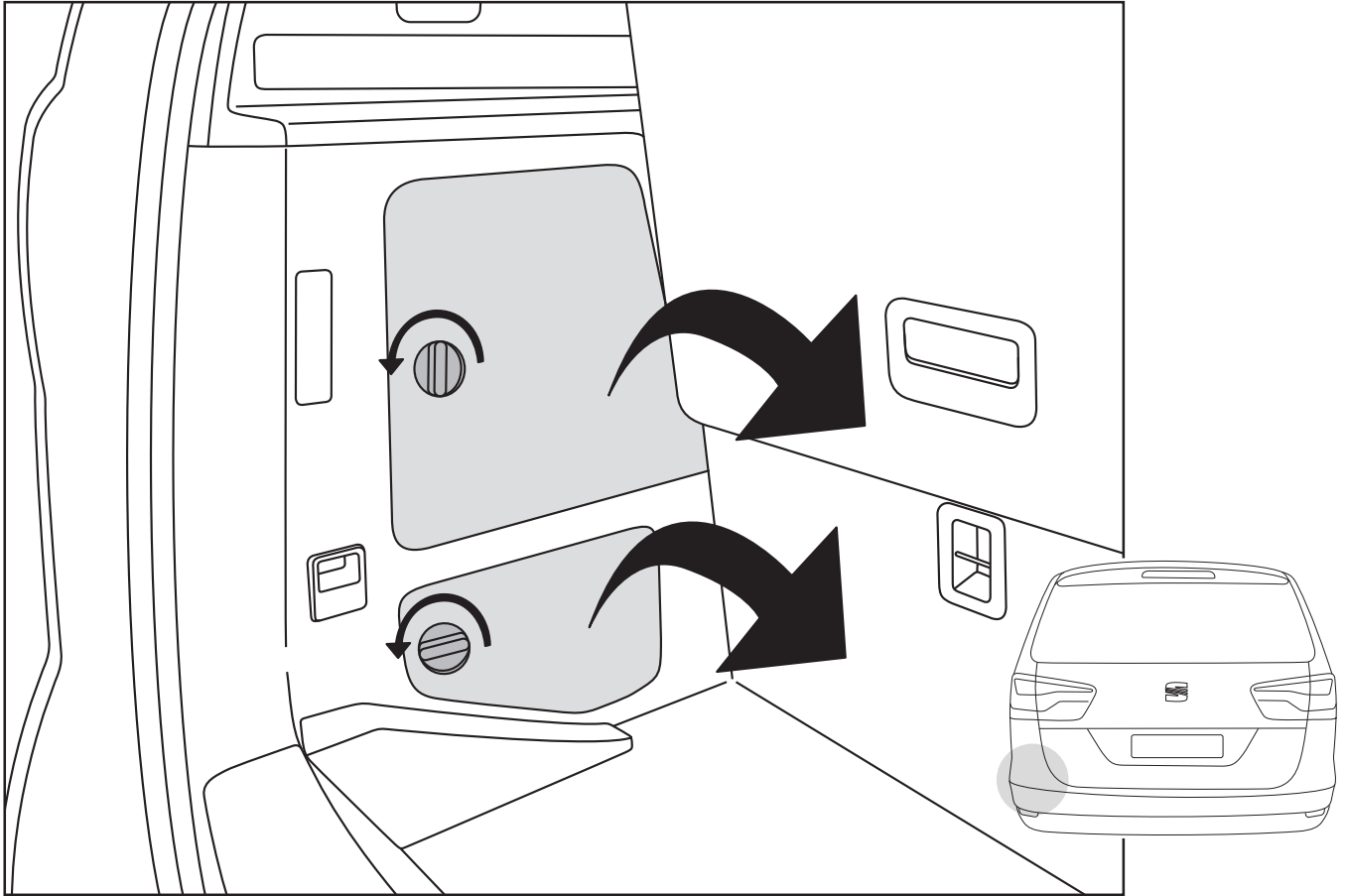

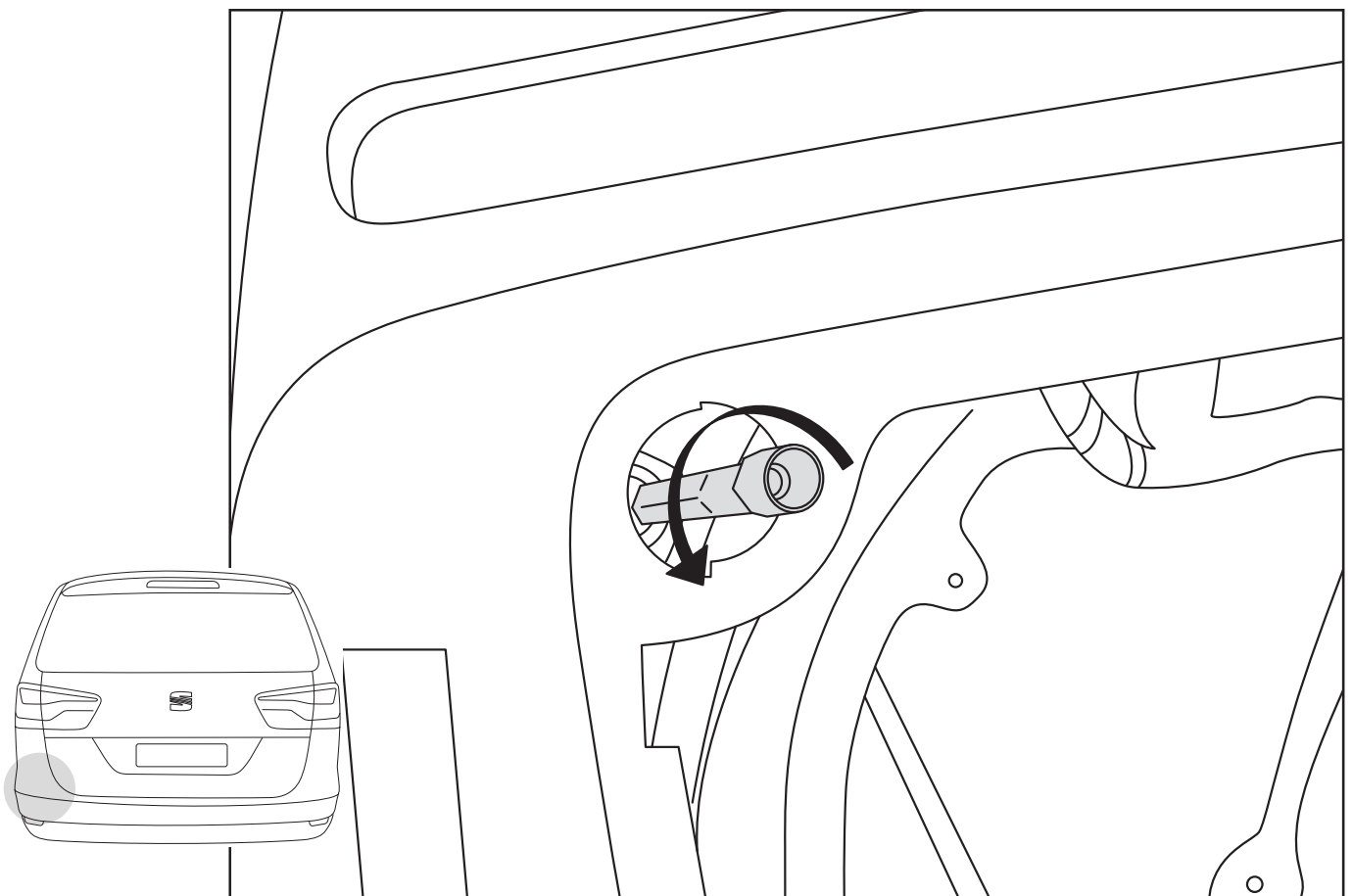
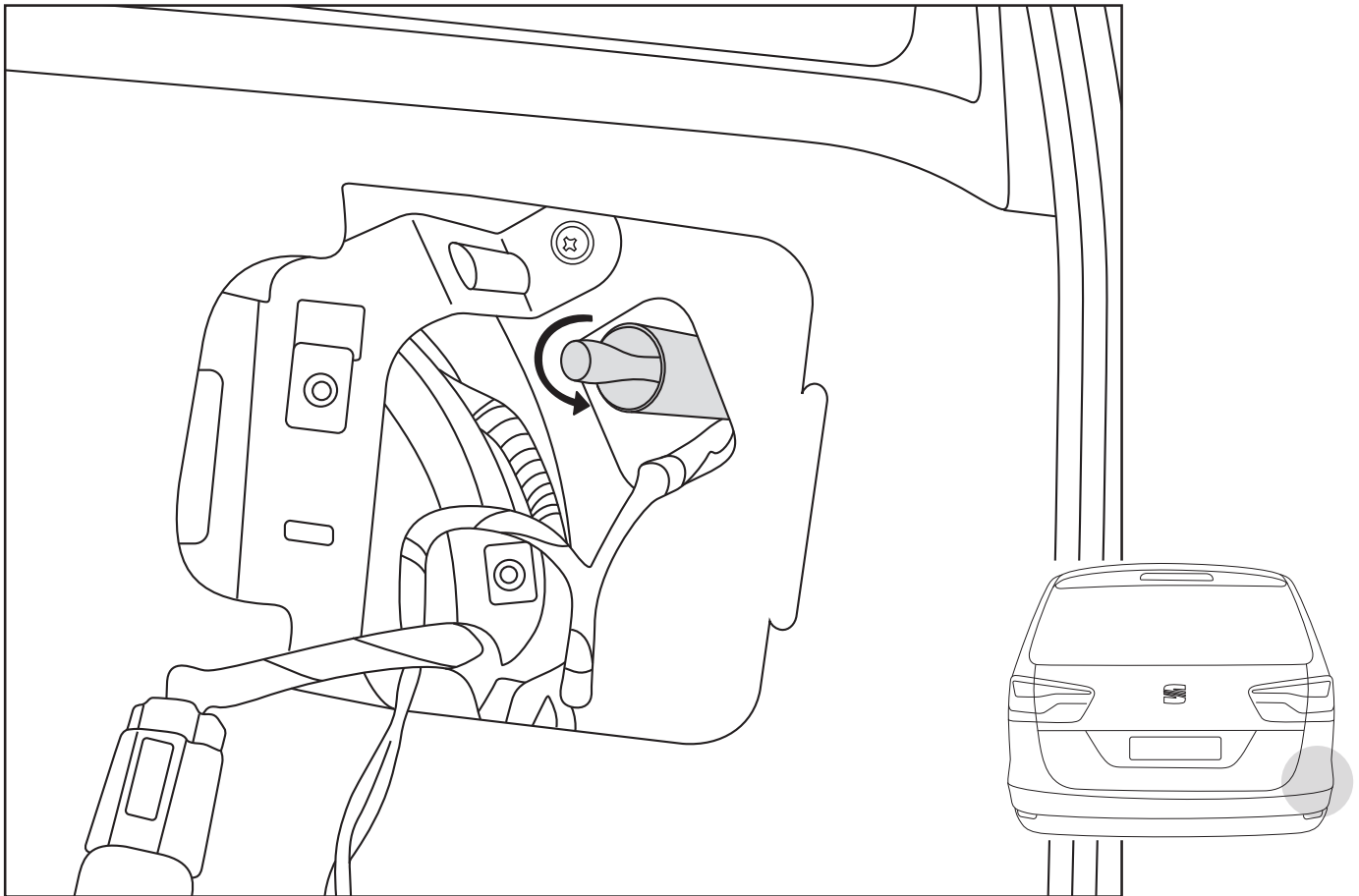

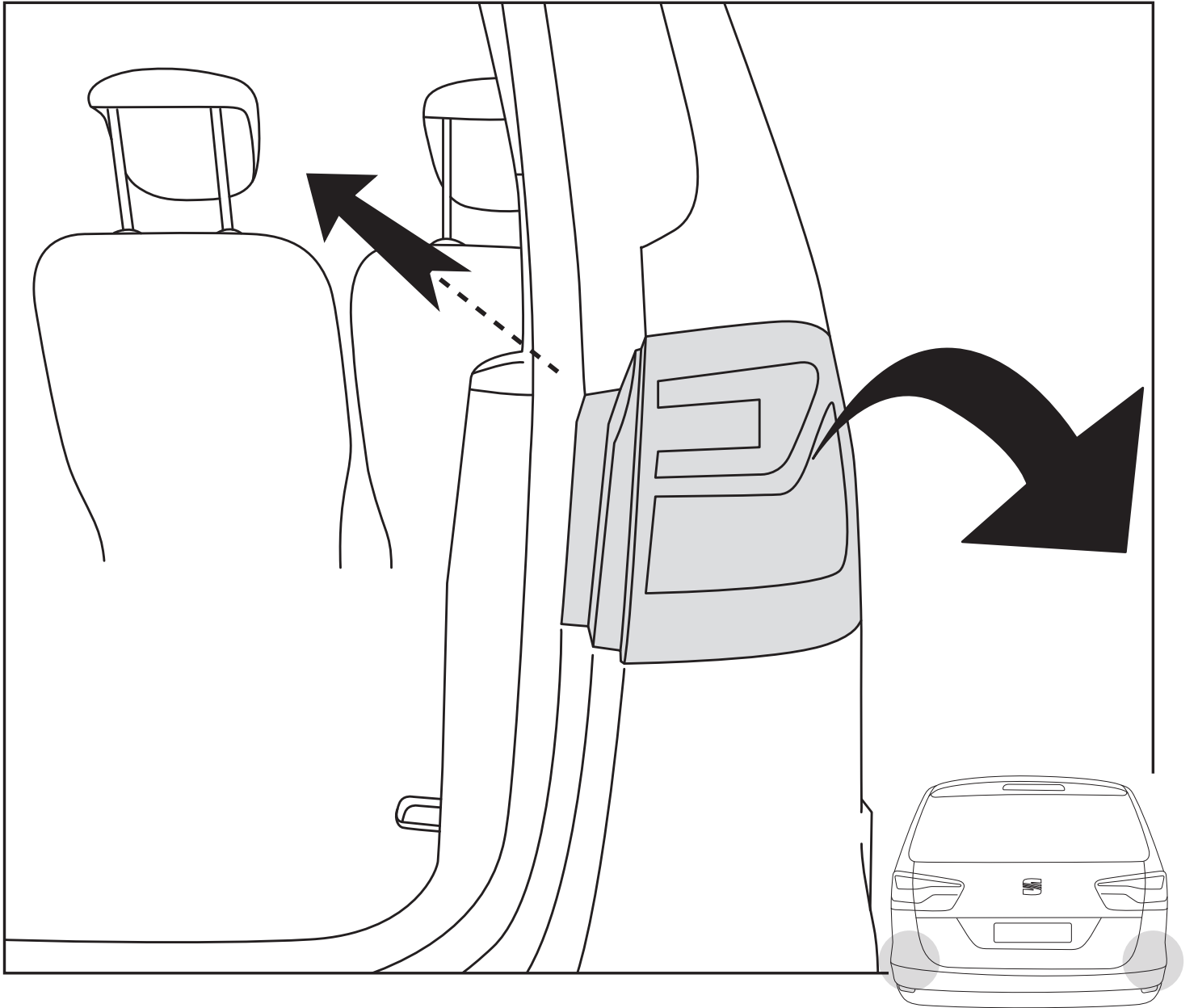

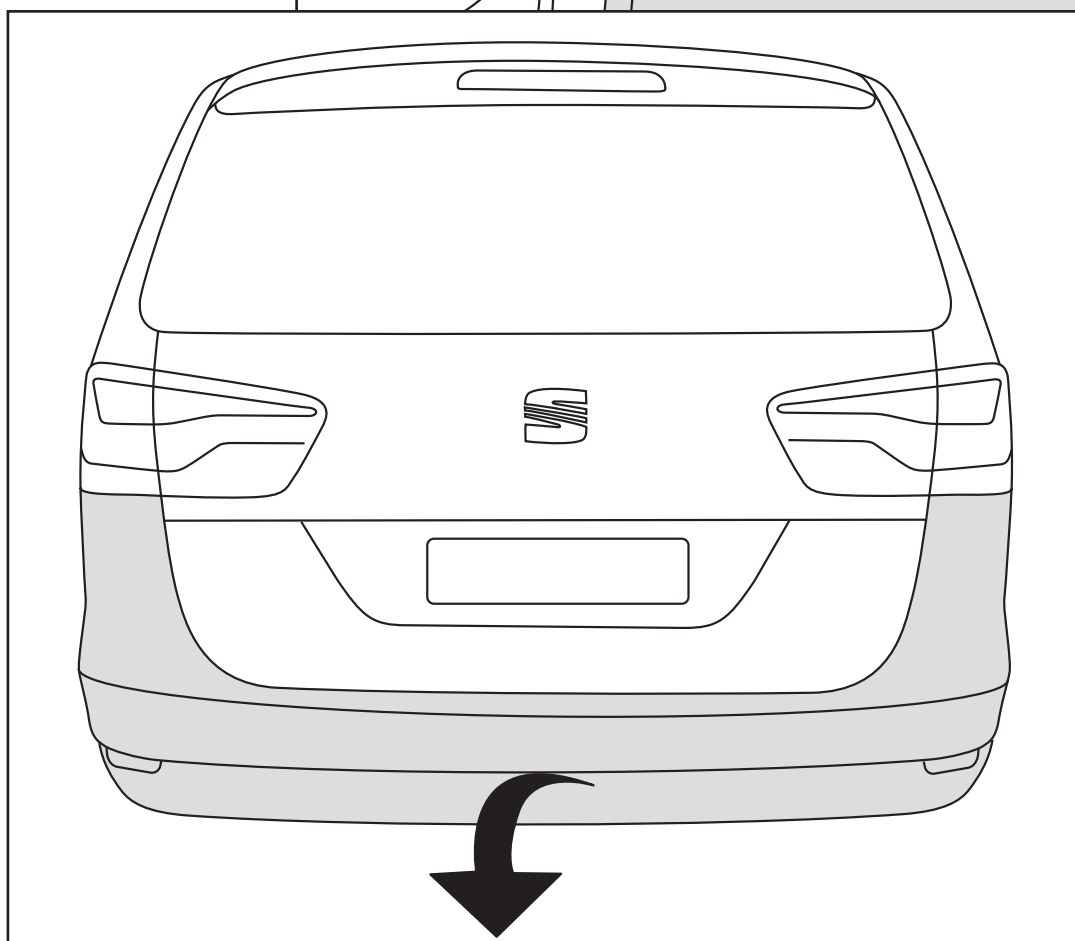
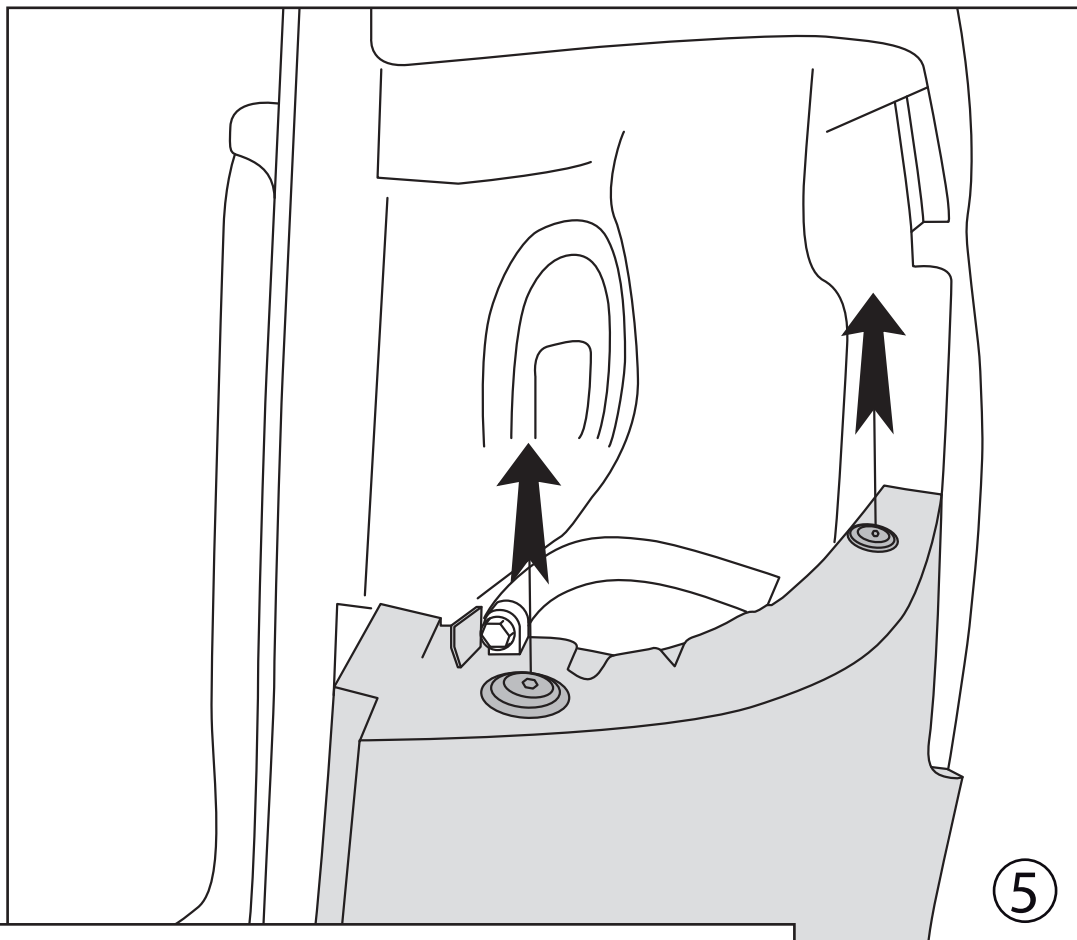

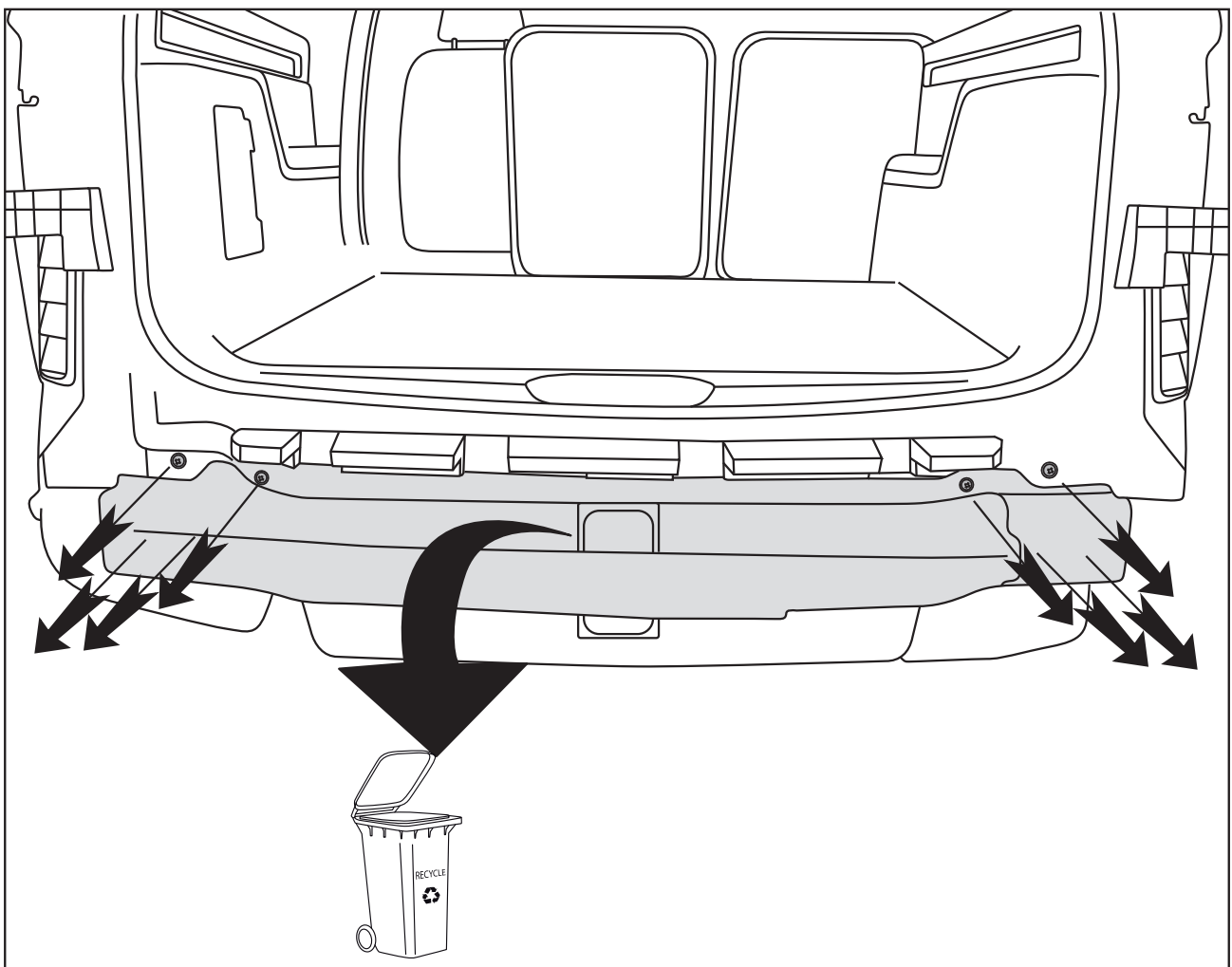
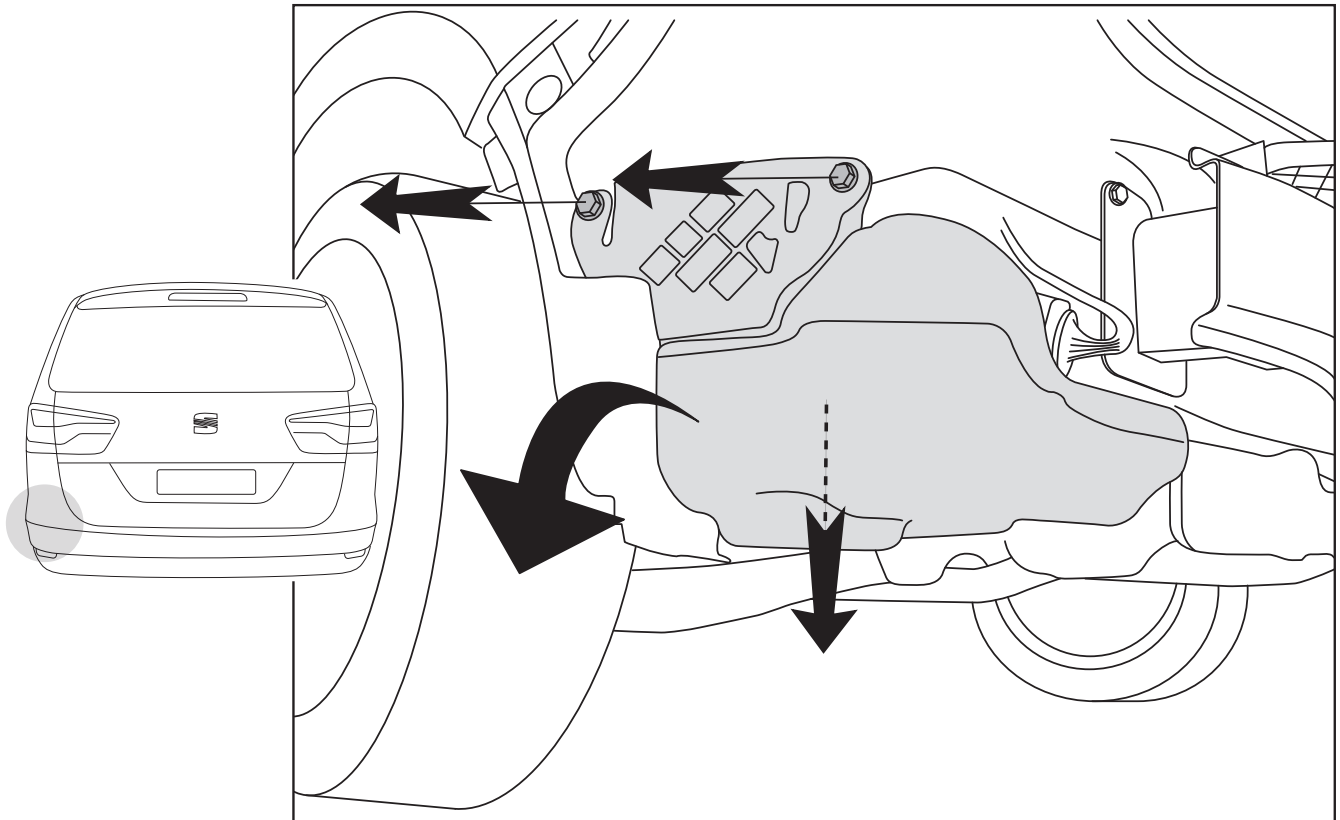

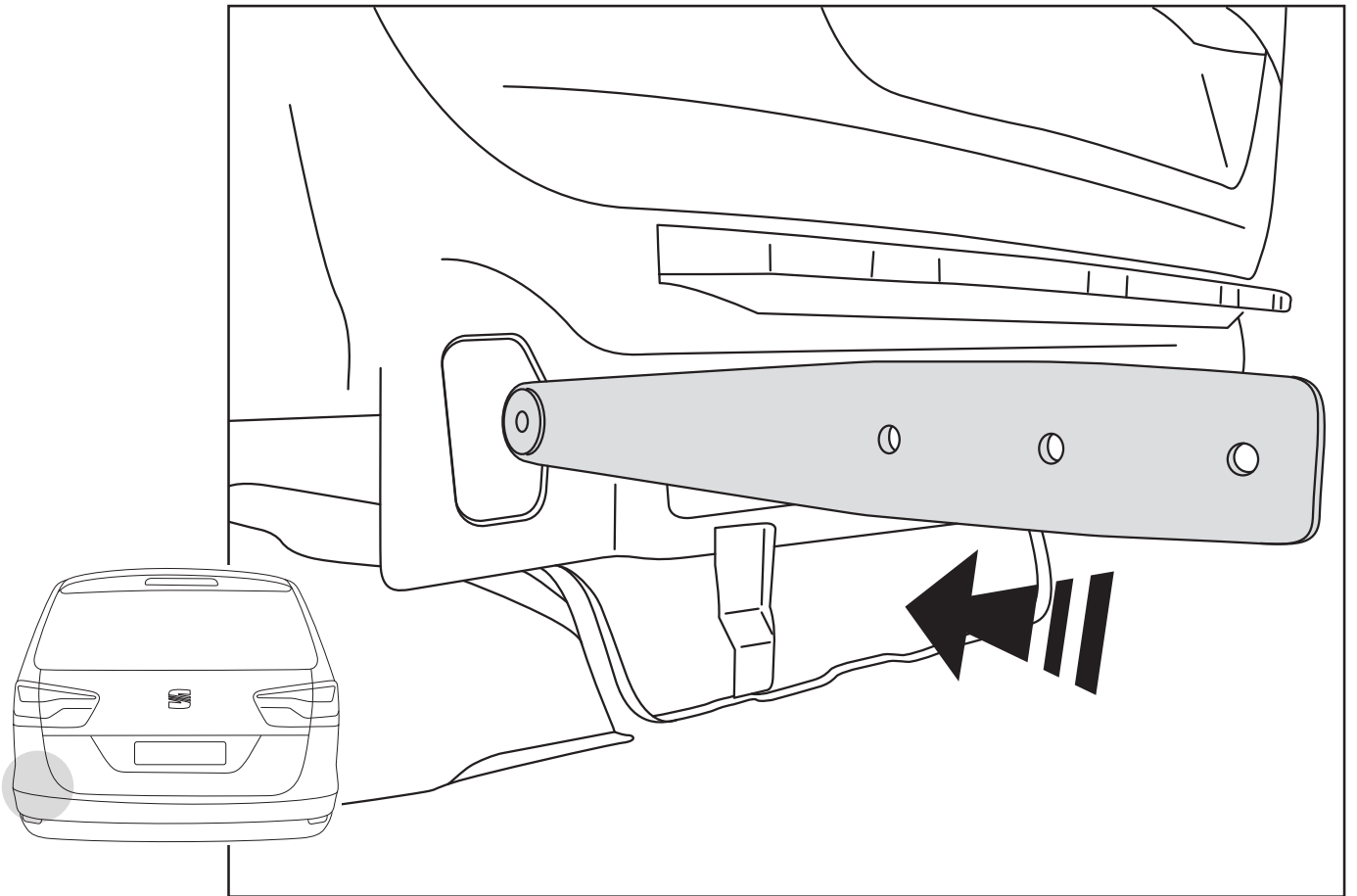
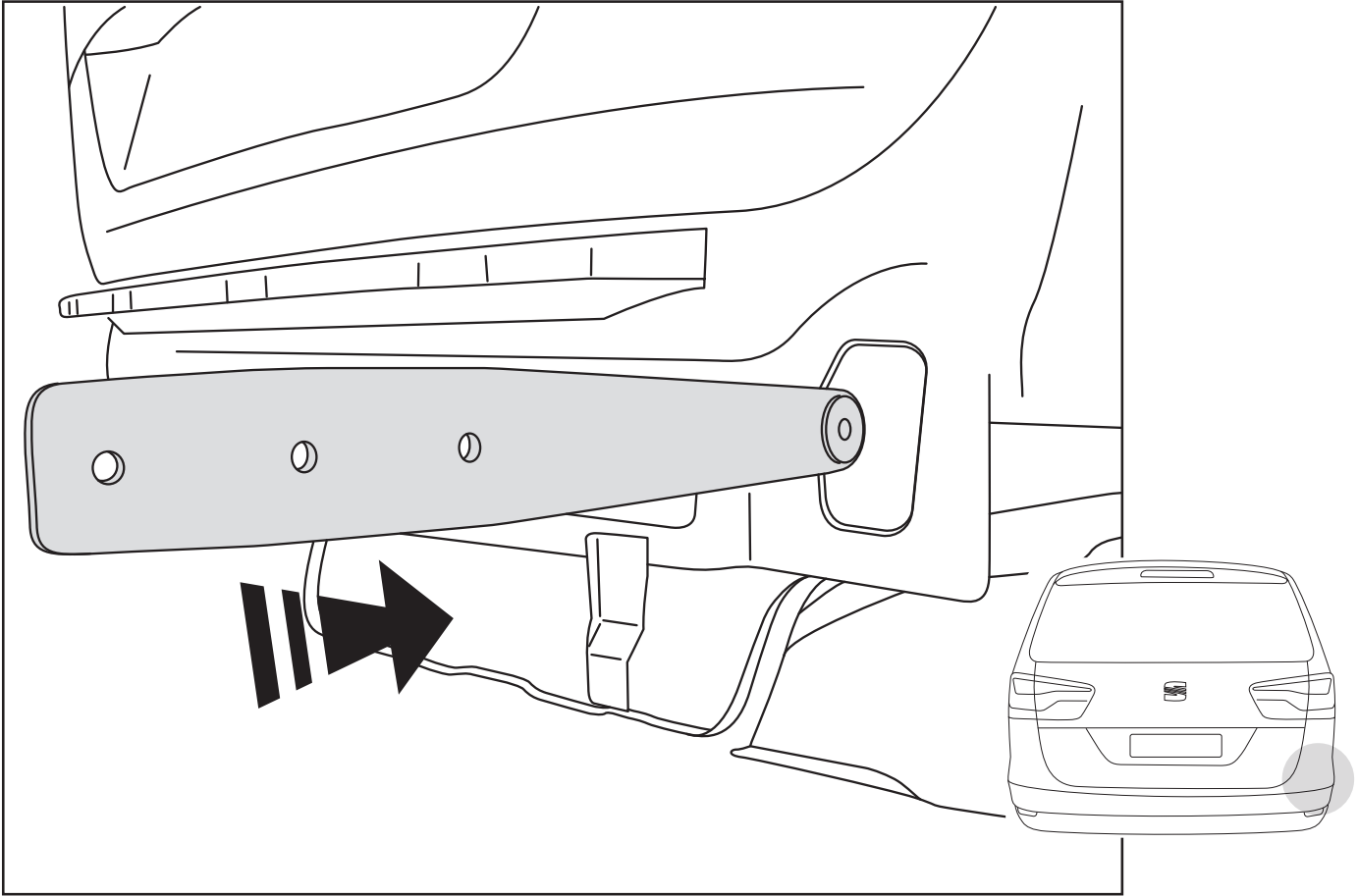

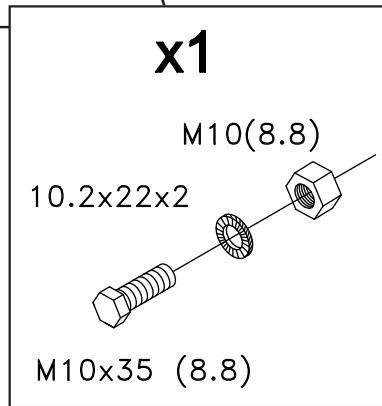
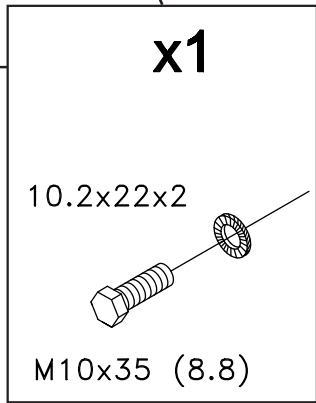
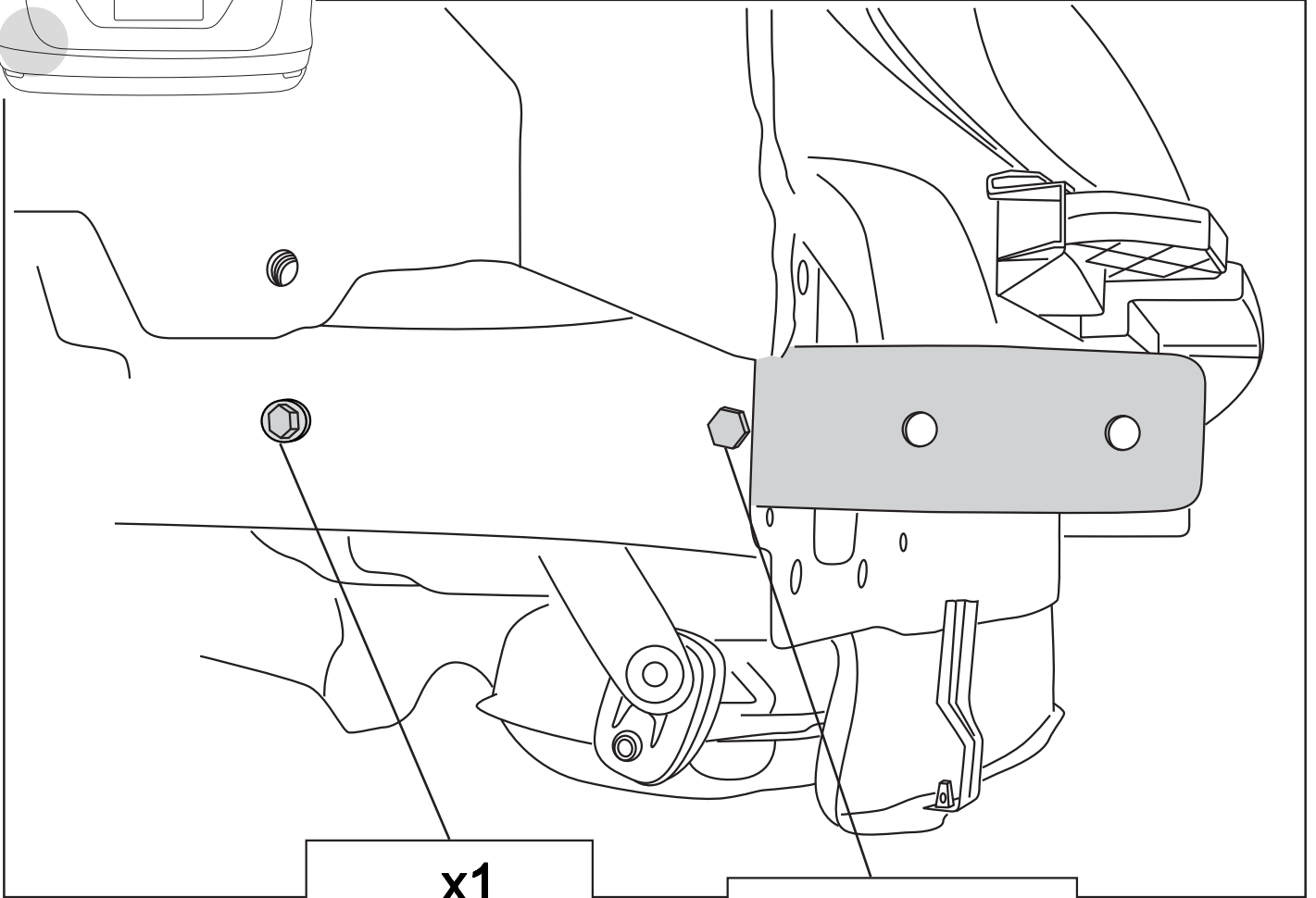
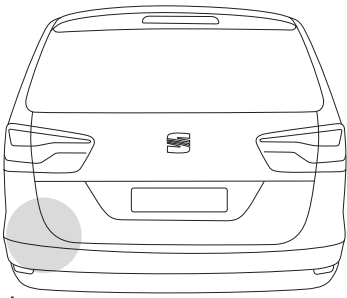

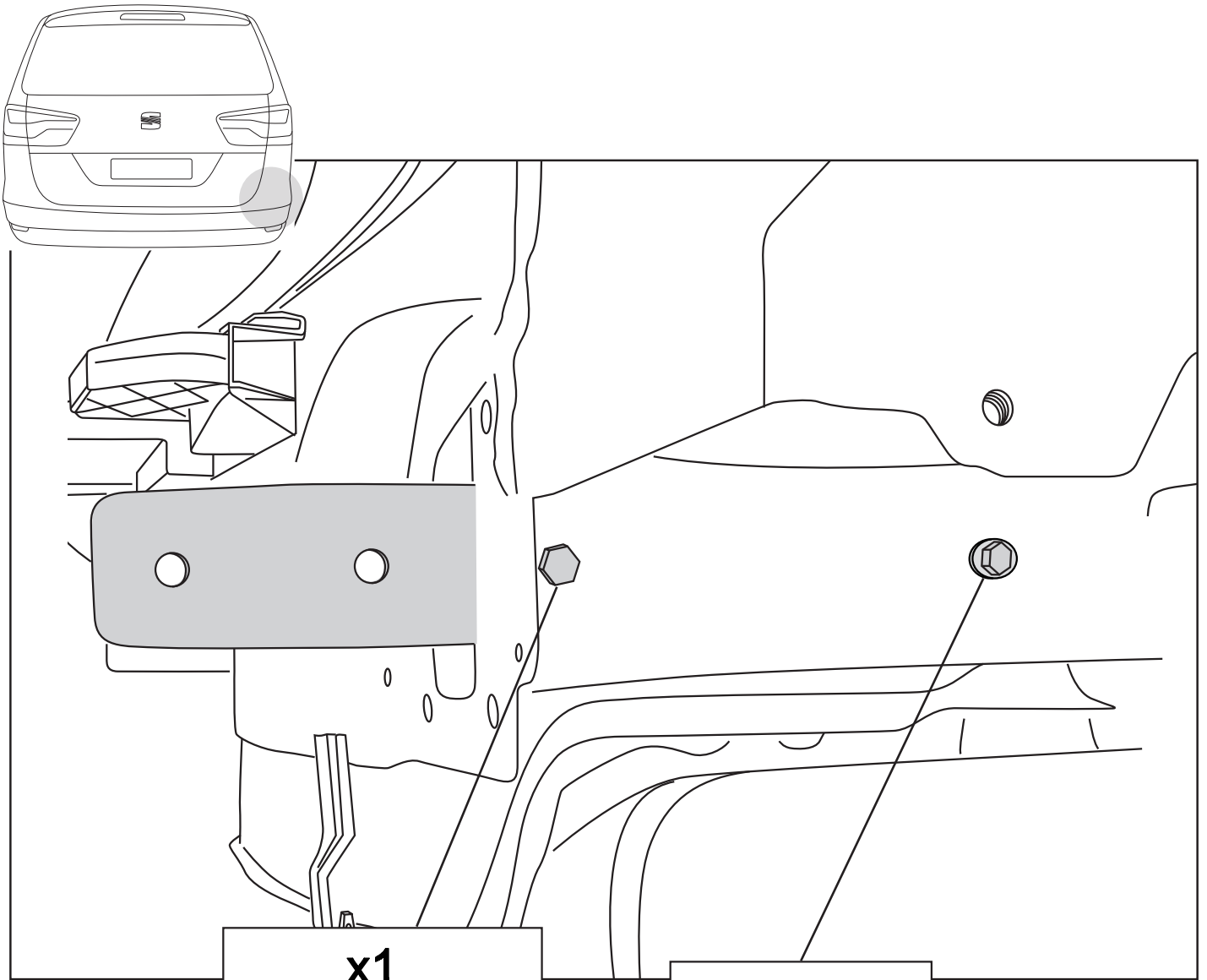

**x1**

M10(8.8)

10.2x22x2

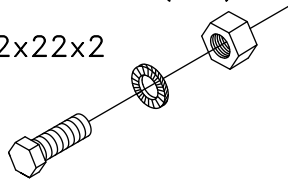

M10x35 (8.8)

**x1**

10.2x22x2

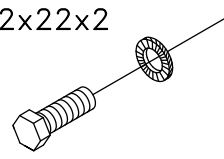

M10x35 (8.8)

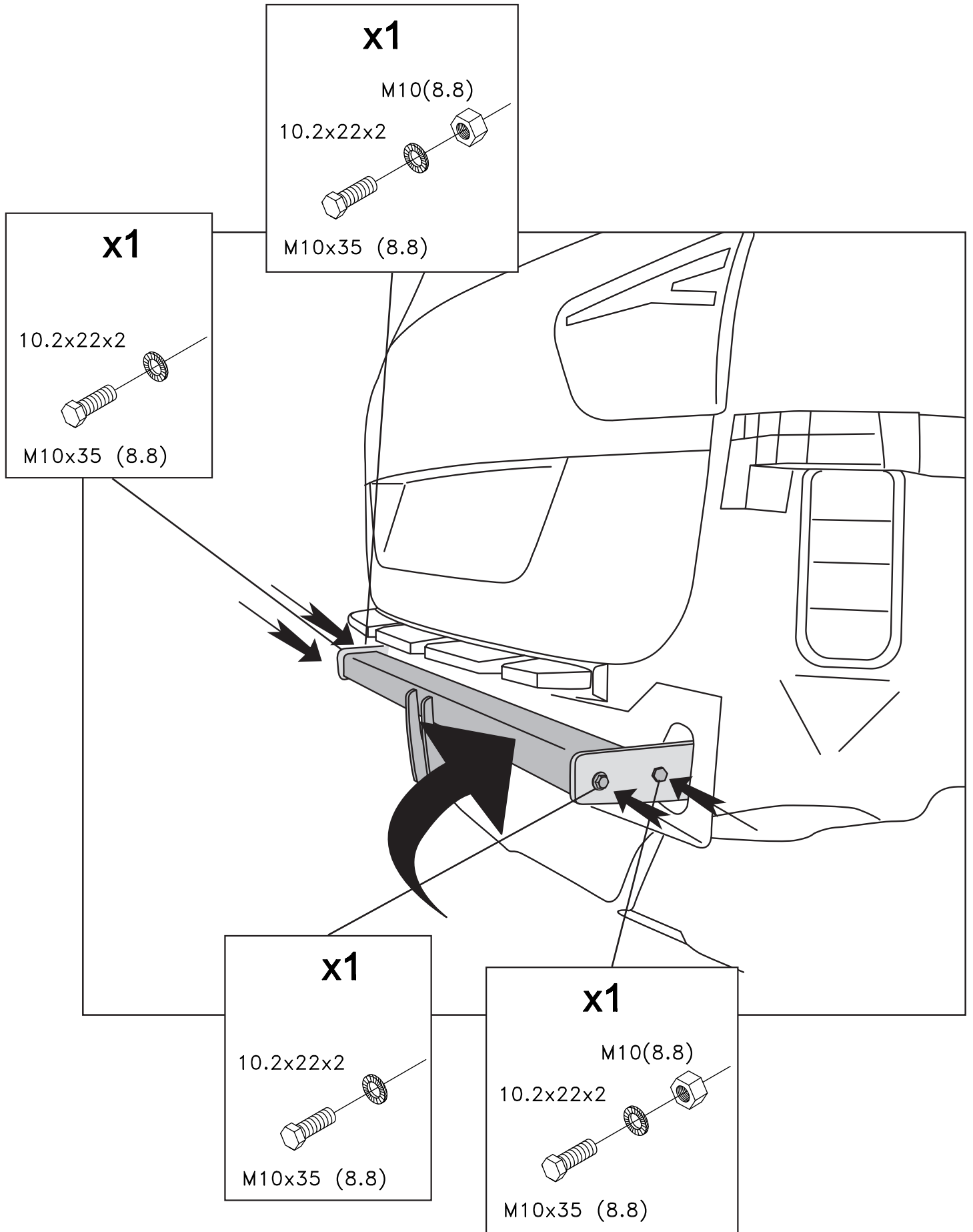

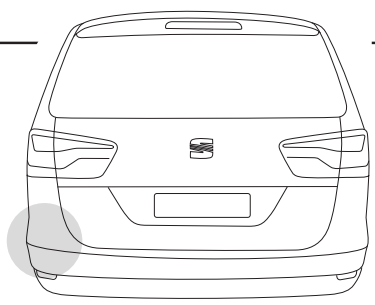
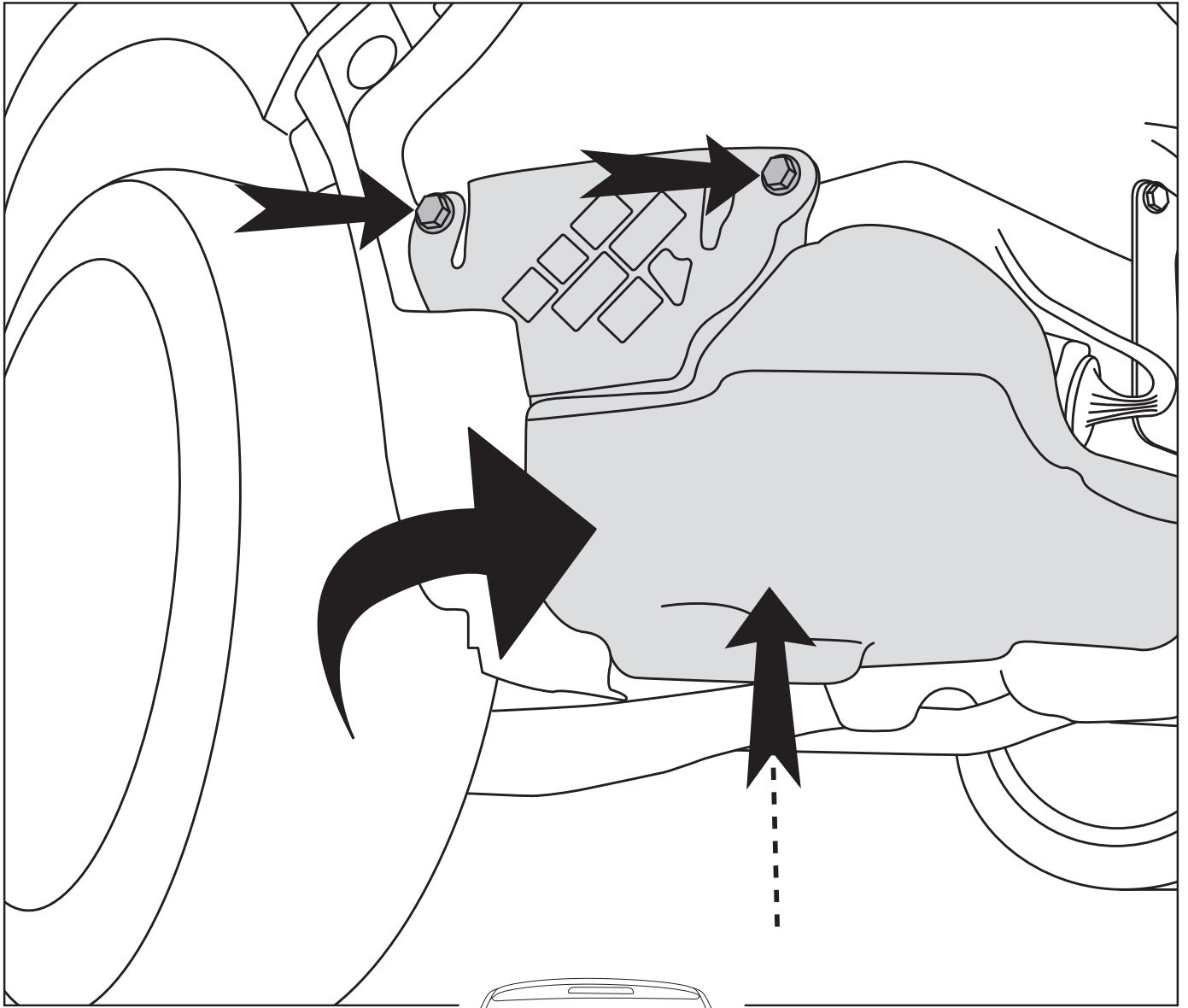

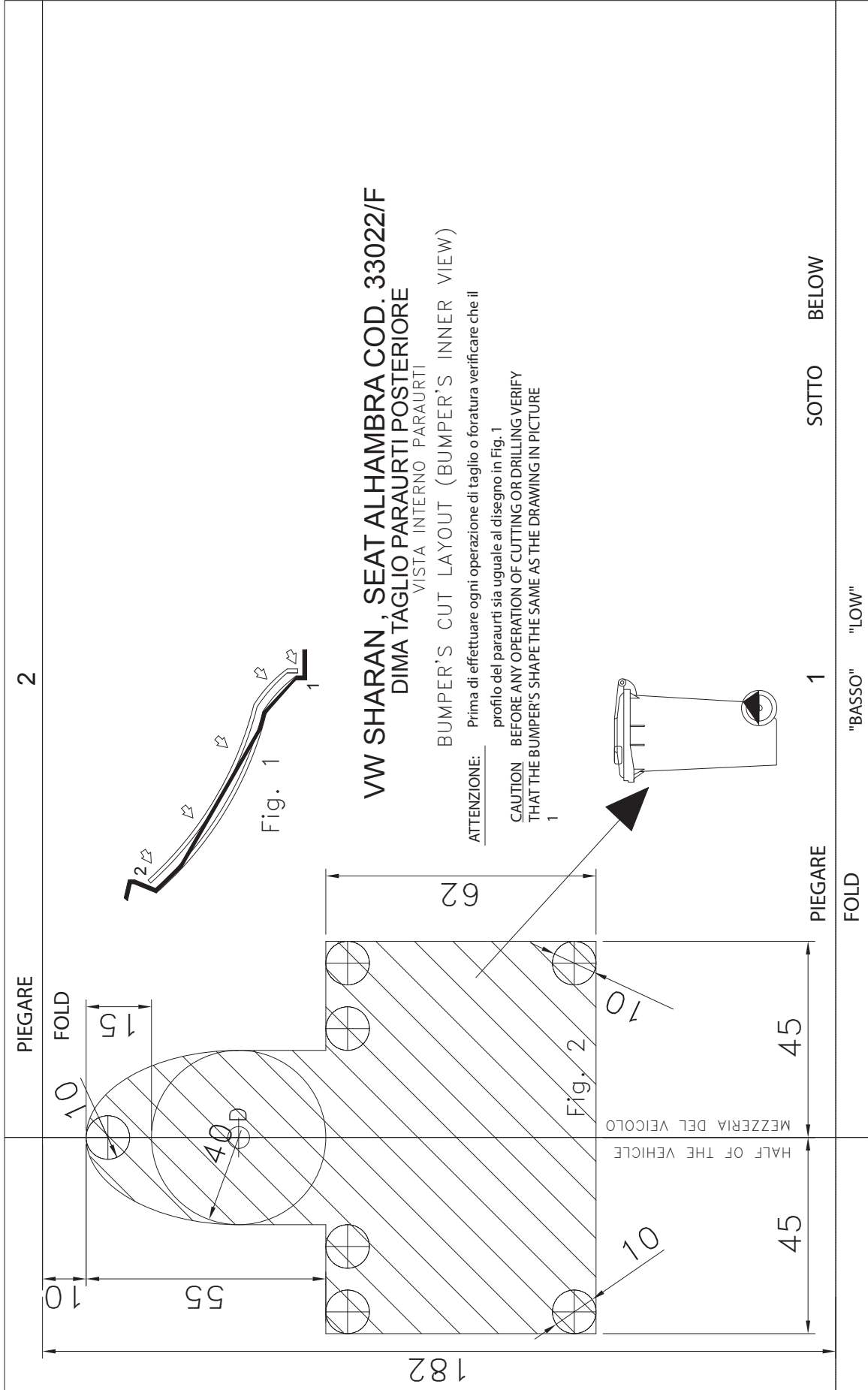

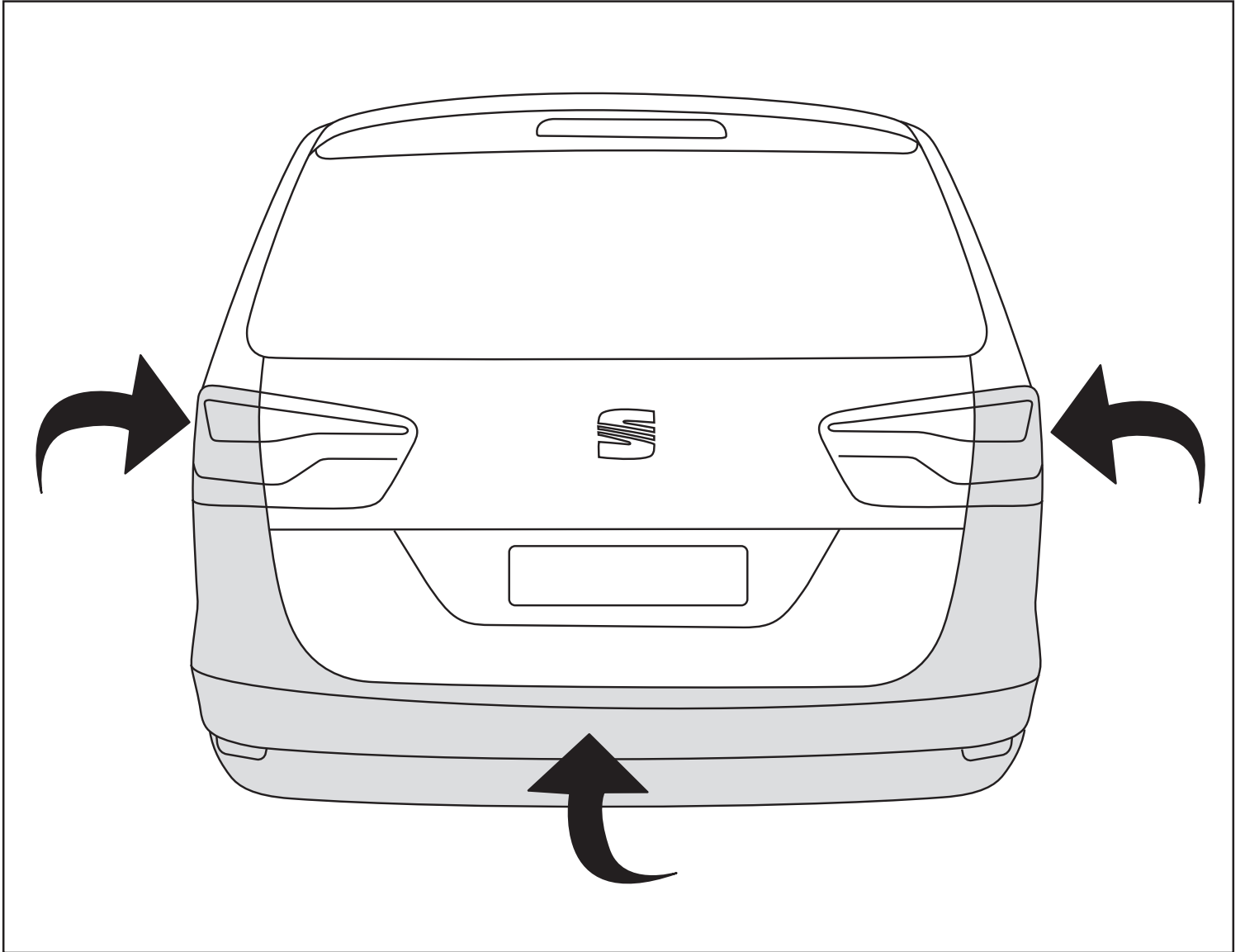

- NL** De tussenruimte conform supplement VII, afbeelding 25 van de richtlijn ECE-R 55 moet in acht worden genomen.
- D** Der Freiraum nach Anhang VII, Abbildung 25 der Richtlinie ECE-R 55 ist zu gewährleisten.
- GB** The clearance specified in appendix VII, diagram 25 of guideline ECE-R 55 must be guaranteed.
- F** La zone de dégagement doit être garantie conformément à l'annexe VII, illustration 25 de la directive ECE-R 55.
- E** Debe garantizarse el espacio libre, conforme al anexo VII, figura 25 de la directiva comunitaria ECE-R 55.
- DK** Frirummet skal overholdes iht. bilag VII, fig. 25 i direktiv ECE-R 55.
- N** Frirommet etter tillegg VII, figur 25 i direktiv ECE-R 55 skal overholdes.
- S** Spelrummet enligt bilaga VII, figur 25 i riktlinje ECE-R 55 skall garanteras.
- FIN** Vapaa tila on taattava direktiivin ECE-R 55 liitteen VII, kuvan 25 mukaisesti.
- I** Deve essere garantito lo spazio libero secondo l'allegato VII, figura 25 della direttiva ECE-R 55.
- CZ** Volný prostor ve smyslu Přílohy VII, obr. 25 Směrnice č. ECE-R 55 musí být zaručen.
- PL** Należy zagwarantować wolną wysokość określoną na rysunku nr 25 dyrektywy ECE-R 55 zawartej w załączniku nr VII.
- H** Az ECE-R 55 irányelv VII. mellékletében, a 25. ábrán a vonógömb elhelyezése számára előírt szabad tér-adatokat biztosítani kell.
- RU** Необходимо обеспечить данные свободного пространства, предписанные для размещения тягового шарика в приложении VII. директивы ECE-R 55.

шарика в приложении VII. директивы ECE-R 55.

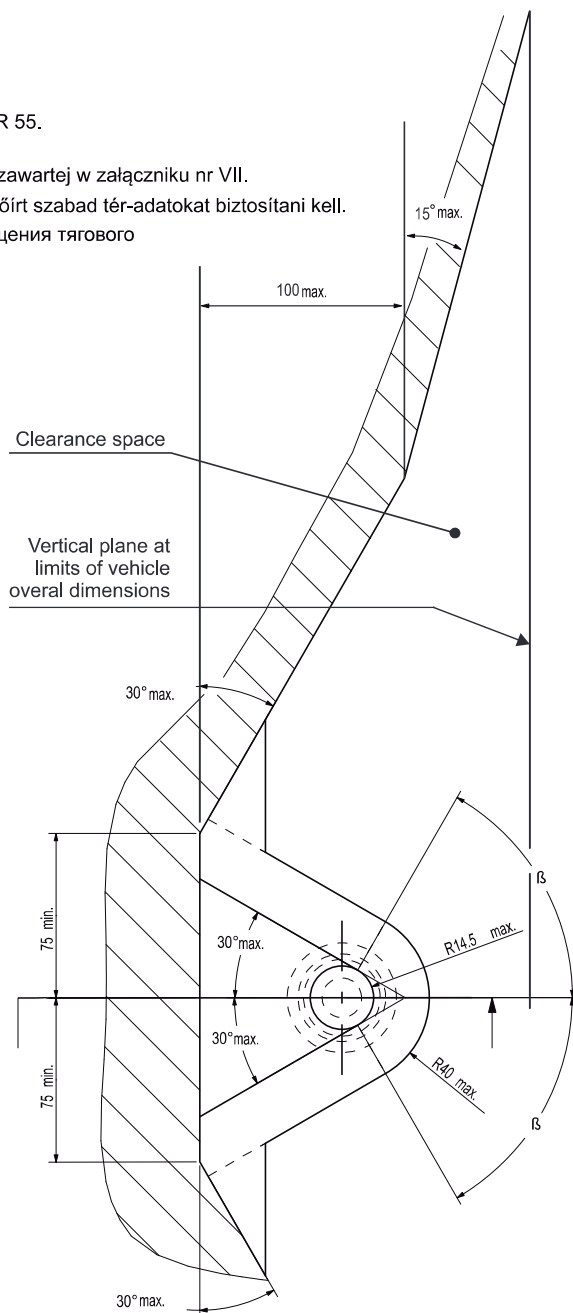
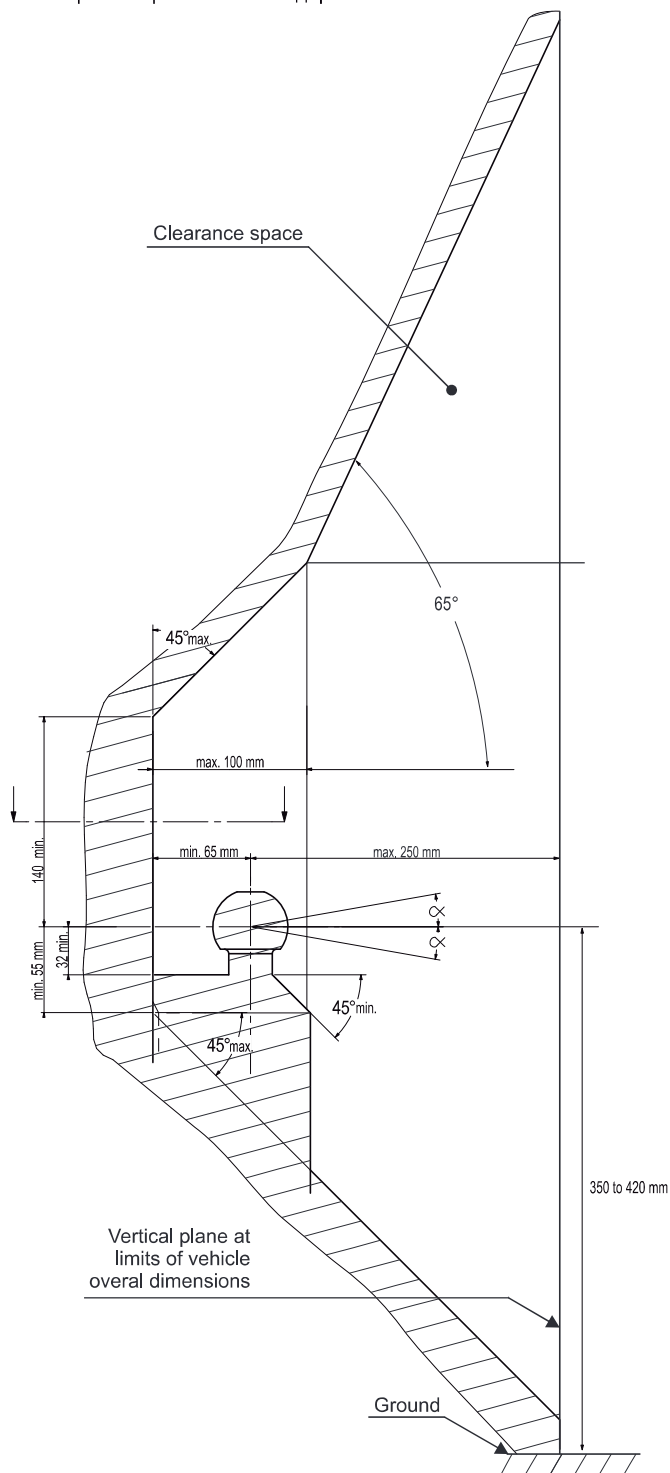

- NL** bij toelaatbaar totaal gewicht van het voertuig
- D** bei zulässigem Gesamtgewicht des Fahrzeuges
- GB** at laden weight of the vehicle
- F** pour poids total en charge autorisé du véhicule
- E** con peso total autorizado del vehículo
- DK** ved tilladt samlet vægt for køretøjet
- N** ved kjøretøyets tillatte totalvekt
- S** vid fordonets tillåtna totalvikt
- FIN** ajoneuvon suurimmalla sallitulla kokonaispainolla
- I** per un peso complessivo ammesso del veicolo
- CZ** při celkové přípustné hmotnosti vozidla
- PL** w przypadku największej dozwolonej masy całkowitej
- H** rakománnyal terhelt járműsúly esetén.
- RU** В случае нагруженного автомобиля.

## LA GARANTIE

En cas d'utilisation de l'attelage, les instructions du constructeur du véhicule concernant le poids tractable maximum autorisé ainsi que la charge verticale maximum sur la boule doivent être respectées. Ces instructions se trouvent dans les documents de bord du véhicule et dans le certificat WVTA. Merci de vous rapprocher du concessionnaire de la marque de votre véhicule afin de connaître son poids maximum tractable. Il est interdit de dépasser les charges données dans les documents qui accompagnent l'attelage.

Avant de tracter, raccorder la connexion électrique, et la chaîne de sécurité qui permet l'arrêt automatique de la remorque en cas de rupture de l'attelage.

Dans un cas extrême, la surcharge de l'attelage peut entraîner sa rupture et la perte du véhicule tracté (remorque, caravane, porte vélo...). La conséquence peut être une blessure grave ou mortelle pour les occupants du véhicule tracteur et/ou les piétons et usagés de la route.

Bosal décline toute responsabilité pour les défauts éventuels du produit causés par une mauvaise utilisation (y compris la surcharge) occasionnée par l'utilisateur.

Il est interdit d'utiliser des points de fixation autres que ceux mentionnés dans la notice de pose de l'attelage.

Avant la commercialisation, tous nos attelages sont soumis à un test dynamique de longévité (2 millions de cycles).

Bosal décline toute responsabilité en cas d'adjonction de stabilisateur ou répartiteur de charge entre le véhicule tracteur et tracté.

La garantie ne s'applique qu'aux produits neufs, Bosal n'engagera pas sa responsabilité sur un produit d'occasion.

## RADARS DE REcul

Il est possible que la rotule soit détecté, dans ce cas, il est nécessaire de la déposer lorsqu'elle n'est pas utilisée.

Bosal recommande fortement le montage de l'attelage démontable sans outil lorsque le véhicule est équipé de radars de recul.