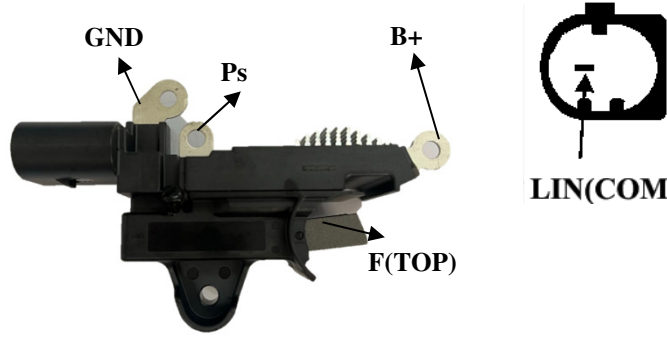

<b>NAME</b>	<b>VR-D290 Electrical Specification</b>	<b>NO</b>	<b>VR-1-1-2467</b>
-------------	---	-----------	--------------------

<p style="text-align: center;"><b>Regulation System Connection Wire Diagram</b></p> 	<p><b>Regulator Features :</b></p> <ul style="list-style-type: none"> <li>● Voltage Set Point : 14.3V (Default Vset )</li> <li>● Regulation : B – Circuit</li> <li>● Standby mode</li> <li>● Leakage current control</li> <li>● Self mode</li> <li>● Default mode</li> <li>● LIN (Com) mode</li> <li>● 9600&amp;&amp;19200 Baud rate ( 4byte )</li> <li>● Variable V setting</li> <li>● Field out duty monitor</li> <li>● Temperature &amp; Field current</li> </ul>
---	--

PARAMETERS AND CONDITIONS	SPEC	Min.	Type	Max.	SYMBOLS
Switch OFF Leakage Current	Ps < 800rpm , LIN= Low , B+=12.0V	---	---	30	mA
Regulator Set Point	Default Mode	14.1	14.3	14.5	V
	Defined by external ECU/LIN command.	10.6	---	16.0	V
Output Saturation Voltage	I F = 5A	---	---	0.5	V
Field Current Limit	F shorted to B+	10	---	---	A
Field Control Frequency	10% < duty cycle < 95%	175	200	225	Hz
Error Display High Temp. Protection Threshold on board(substrate)	Field output OFF	---	160	---	℃
Self Drive Initiation rpm Threshold	Safe mode Frequency given according to the programmed number of generator poles	2550	3000	3450	rpm

**Safety Characteristics:**

- **Over voltage :** Vs = 24 V , 60 sec. from the ignition SW. is turned ON/OFF without failure.
- **Short Circuit Protection :** The regulator shall stand **short circuit on Field** without failure and return normal operation within 2 seconds once short condition is removed.
- **Repetitive Thermal Shock :** The Regulator shall be designed to withstand 500 cycles of -30℃ to 125℃ in 20 minutes and 125℃ to -30℃ in 20 minutes.
- **High Temperature Test :** The regulator shall be designed to operate reliably at the load from 80% to 100% of the alternator rated current and at 6000 rpm ( shaft speed ) for a minimum of 10 hours at 125℃.

2024.04.10		1	張家豪	柯文彬	林勝雄	林勝雄		
<b>DATE OF FIRST EDITION</b>	<b>DATE OF REVISED EDITION</b>	<b>EDITION</b>	<b>MANU-SCRIPT</b>	<b>ORI-GINAL REVIEW</b>	<b>SECOND REVIEW</b>	<b>APP-ROVAL</b>	<b>ISSUED MARK</b>	<b>COPY'S NUMBER</b>